

TABLE OF CONTENTS

1. OVERVIEW	1
2. INSTALLATION	2
2.1. COOLING	2
2.1.1. Fan Exhaust	2
2.2. MOUNTING	3
2.3. POWER	4
2.3.1. Connecting the Power	4
2.3.2. Connecting DC Power to the Frame	5
2.3.2.1. External Power Supply 350PSX	5
2.3.2.2. Anton Bauer Quad Pack MBL-IIRCBH+AB	5
2.3.3. Turning the Power On and Off	5
2.3.4. Power Supply Status Indicators	6
2.4. FRAME STATUS FAULT CONDITIONS.....	7
3. INSTALLING AND REMOVING THE MODULES.....	8
3.1. INSTALLING THE MODULE REAR PLATES	8
3.2. OPENING AND CLOSING THE FRONT PANEL.....	8
3.3. INSTALLING THE MODULES	8
3.3.1. Slot Blocker	8
3.4. REMOVING THE MODULES	9
4. TECHNICAL DESCRIPTION.....	10
4.1. SPECIFICATIONS.....	10
4.1.1. Electrical – 350FR Frame	10
4.1.2. Electrical – 350PSX External Power Supply	10
4.2. COMPLIANCE.....	10
4.3. PHYSICAL.....	10
5. SERVICING INSTRUCTIONS	11
5.1. CHANGING THE FUSES	11
5.1.1. 350FR Frame Power Supply	11
5.1.2. MBL-IIRCBH+AB Anton Bauer Quad Pack.....	11

5.2. REPLACING THE POWER SUPPLY	11
5.3. INSTALLING THE PORTABLE CARRY HANDLE AND RUBBER FEET (350FR-PPKIT).....	13
5.3.1. Installing the Portable Carry Handle.....	13
5.3.2. Installing the Rubber Feet	14
5.3.3. 350FR-FBB Hermaphroditic Fiber Breakout Bracket Installation	15

Figures

Figure 2-1: 350FR Dual Unit Tray.....	3
Figure 2-2: 350FR Power Supply Rear Panel.....	4
Figure 2-3: DC Power Connector to Frame	5
Figure 2-4: 350PS Status Indicators.....	6
Figure 3-1: Slot Blocker (E7700FR-SLOT-BLOCK).....	8
Figure 5-1: Locating the Power Supply Mounting Screw.....	12
Figure 5-2: Portable Carry Handle Installation.....	13
Figure 5-3: Rubber Feet Installation	14
Figure 5-4: Fiber Breakout Bracket Contents and Final Assembly.....	15
Figure 5-5: Step 1 – Preparing 350FR for Breakout Bracket Installation.....	15
Figure 5-6: Step 2 – Attach Fiber Breakout Bracket and Fiber Breakout to 350FR Frame	16

REVISION HISTORY

<u>REVISION</u>	<u>DESCRIPTION</u>	<u>DATE</u>
1.0	First Release	Oct 2007
1.1	Added Fiber Breakout Bracket Installation Instructions	Jan 2008
1.2	Updated Figure 2-3 DC Power Connector to Frame	Apr 2008
1.3	Updated electrical specifications	May 2008
1.4	Added slot blocker information	Sept 2010

Information contained in this manual is believed to be accurate and reliable. However, Evertz assumes no responsibility for the use thereof nor for the rights of third parties, which may be effected in any way by the use thereof. Any representations in this document concerning performance of Evertz products are for informational use only and are not warranties of future performance, either express or implied. The only warranty offered by Evertz in relation to this product is the Evertz standard limited warranty, stated in the sales contract or order confirmation form.

Although every attempt has been made to accurately describe the features, installation and operation of this product in this manual, no warranty is granted nor liability assumed in relation to any errors or omissions unless specifically undertaken in the Evertz sales contract or order confirmation. Information contained in this manual is periodically updated and changes will be incorporated into subsequent editions. If you encounter an error, please notify Evertz Customer Service department. Evertz reserves the right, without notice or liability, to make changes in equipment design or specifications.

This page left intentionally blank

1. OVERVIEW

The 350FR is a portable 3 rack unit high half sized frame for the 7700 series modular system. This advanced rack frame design can house up to 7 modules of any combination and incorporates today's video/audio processing, distribution, and fiber optic needs in one portable package. The ability to handle the high-speed requirements of 3G, HD, SD, Analog in both the Electrical and Optical domain makes the 350FR an ideal portable solution.

Care has been taken to ensure sufficient thermal relief for up to 100 watts of processing power per frame, to meet the increasing power demands of future high speed processing cards.

Hot-swappable redundant switching power supplies and cooling fans allow power supply or fan replacement without compromising the integrity of critical signal paths.

The front-loading design permits extraction of the power supplies and active modules from the front without compromising performance even at 3Gb/s. Thus, there is no need for time consuming re-cabling nor is there need to have access to the rear of the frame to replace or exchange modules.

Features:

- Houses up to 7 front loading 7700 series processing modules
- Each slot has individually configurable inputs and outputs
- Front monitoring window for verifying module and power supply status
- Front extractable modules, power supplies and fans
- No re-cabling required when hot-swapping modules
- Auto-ranging power supply that operates from 100-240VAC at 50/60hz
- External power supply has auto-ranging power supply that operates from 11 to 13 VDC
- Power supply and frame cooling fans are fully redundant and hot-swappable
- High-speed bussing and control system provided for modular applications
- 350FR can house a 7700FC VistaLINK[®] Frame Controller in slot 1 which will allow for remote control and monitoring of VistaLINK[®] capable products via SNMP
- Optional redundant external power supply
- Optional dual unit tray
- Optional Anton Bauer Quad battery holder
- Optional Portable kit containing 1 top handle & 4 rubber feet

2. INSTALLATION

2.1. COOLING

The 350FR frame is designed to ensure adequate cooling for up to 100 watts of processing power per frame. Fans at the front and rear of each power supply module accomplish forced air cooling. Adjacent equipment may be mounted immediately to the top and bottom of the 350FR frame. Additional module cooling is provided by interior cooling channels to ensure that even fully loaded frames mounted adjacent to each other will operate within the normal temperature range.



For proper cooling, the frame must contain the 350PS power supply even if it is being powered by DC Power.

2.1.1. Fan Exhaust

The cooling fan for the power supply, located at the front of the frame, draws air in the front and exhaust out the side of the frame. The cooling fan for the card frame, located at the rear left side of the frame, draws air in the front and exhaust out the left side of the frame at the rear.

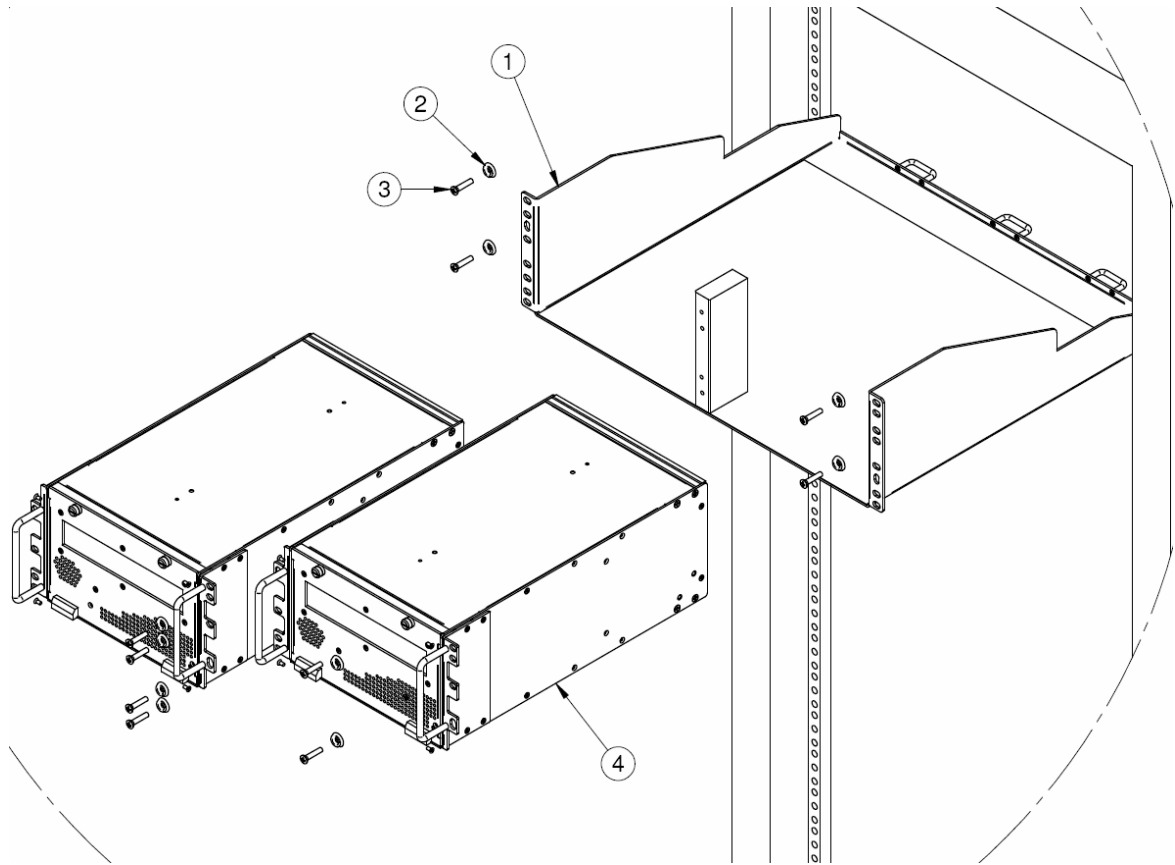

CAUTION: To ensure adequate cooling, care should be taken to ensure that the fan inlets and exhaust openings are free of obstructions.

2.2. MOUNTING**Figure 2-1: 350FR Dual Unit Tray**

The 350FR Rack frame requires the 350FR-RP dual unit tray, and 3 rack units, i.e. 5.25 inches (133 mm) of standard 19 inch (483 mm) wide rack space. To securely fasten the rack mount kit to the equipment rack, make sure that all four mounting screws are tightened securely. Fasten each frame to one of the two slots of the tray with 4 mounting screws.

2.3. POWER

2.3.1. Connecting the Power

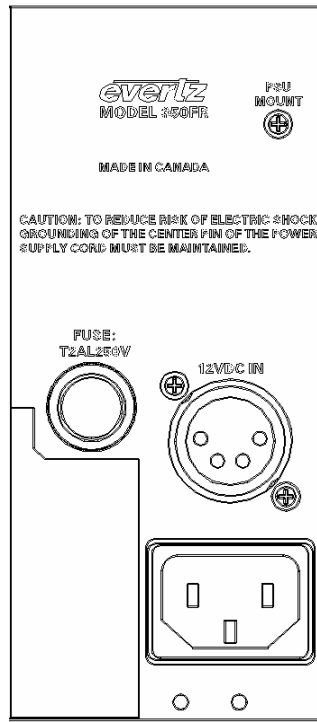

Figure 2-2: 350FR Power Supply Rear Panel

The 350FR frame comes standard with one auto-ranging power supply that automatically senses the input voltage over the range of 100 to 240 VAC. An additional external power supply (350PSX) can be ordered to provide fully redundant powering of the frame. Power should be applied by connecting a 3-wire grounding type power supply cord to the power entry module on the rear panel of each power supply. The power cord should be minimum 18 AWG wire size; type SVT marked VW-1, maximum 2.5 m in length.

The power entry module contains a standard IEC power inlet connector and an EMI line filter. A separate 5 x 20 mm fuse holder is provided for the AC fuse. See section 5.1 for information on changing the fuse.



CAUTION - TO REDUCE THE RISK OF ELECTRIC SHOCK, GROUNDING OF THE GROUND PIN OF THE MAINS PLUG MUST BE MAINTAINED

2.3.2. Connecting DC Power to the Frame

2.3.2.1. External Power Supply 350PSX

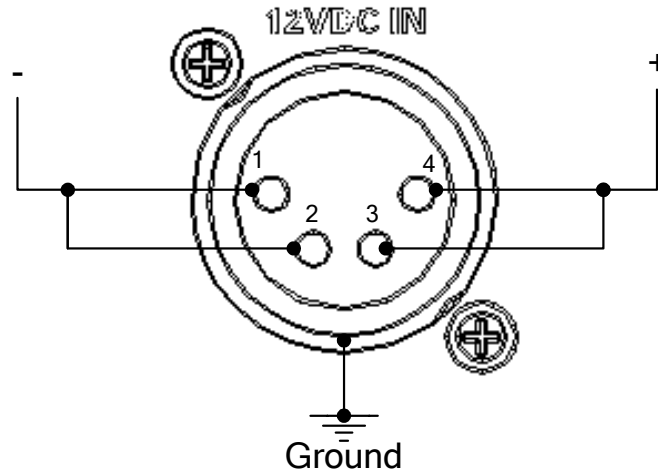

Figure 2-3: DC Power Connector to Frame

An additional external power supply 350PSX can be ordered to provide fully redundant powering of the frame. Power should be applied by connecting the 4-pin XLR power connector from the 350PSX external power supply to the back of the frame labeled "12 VDC IN".

Power should be applied to the external power supply, by connecting a 3-wire grounding type power supply cord to the power entry module on the power supply. The power cord should be a minimum 18 AWG wire size; type SVT marked VW-1, maximum 2.5 m in length.

2.3.2.2. Anton Bauer Quad Pack MBL-IIRCBH+AB

An additional external power supply MBL-IIRCBH+AB can be ordered to provide fully redundant powering of the frame as well. Power should be applied by connecting the 4-pin XLR power connector from the MBL-IIRCBH+AB to the 4-pin XLR power connector on the back of the 350FR frame labeled "12 VDC IN". At least two Gold Mount batteries are required to power the frame (batteries not included).

2.3.3. Turning the Power On and Off

The built in power supply is fitted with a power switch. When the switch is turned off, the external power supply connected to the 12VDC input will power the 350FR frame. To completely remove power from the frame, both power supplies must be turned off.

2.3.4. Power Supply Status Indicators

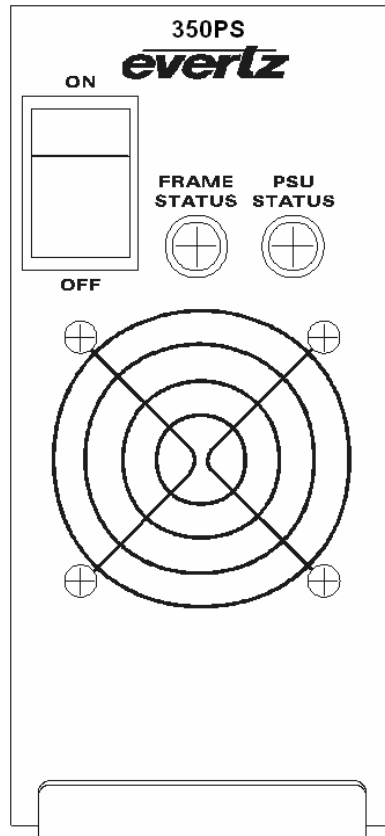

Figure 2-4: 350PS Status Indicators

The power supply has two status indicator LEDs. The green PSU STATUS LED indicates the health of the local power supply. The red FRAME STATUS LED indicates the health of the entire frame and is operated by the frame status buss of the frame. The FRAME STATUS LED will be Off under normal conditions and On when there are Frame Status Fault conditions. See section 2.4 for more information about frame status buss fault conditions.

If the main internal power supply malfunctions (while redundant power supply connected), (power cord disconnected, power switch is off, fuse is blown, etc.) then its PSU STATUS LED will go off, and the red FRAME STATUS LED will turn On. If the frame is connected to VistaLINK® then the power supply fault will send a trap message from the frame.



If there is a fuse failure, contact Evertz customer service regarding the power supply immediately. The power supplies are short circuit protected and should not blow the fuse under a short circuit condition.

2.4. FRAME STATUS FAULT CONDITIONS

The frame is fitted with a global Frame Status monitoring buss that is connected to the power supply and to each of the modules. When a fault condition occurs on the power supply, or one of the modules, a Frame Status Fault condition is active on the frame status buss. When this occurs the red FRAME STATUS LED on the power supply will light up.

Power supplies will assert a frame status fault when their PSU STATUS LED is off.

Each module has a large red LOCAL FAULT LED and a large green MODULE OK LED at the top of the card edge. This green LED indicates good module health while the red LED indicates that there is a fault condition on the module. Each module has its own criteria that determines when the red fault LED comes on. When the red LOCAL FAULT LED is On the module can also assert a fault condition on the Frame Status buss.

On each module there is a jumper that disables sending local card fault information to the Frame Status Buss. For more information about fault conditions on individual modules, and for the location of the Frame Status Jumper on the module consult the individual chapter for the module. For example, if a module requires video or audio for its functionality and the video or audio is not present, the red LOCAL FAULT LED on the module will be On and the fault will be reported on the frame status buss if the FRAME STATUS jumper on the module is set to the On position (default).

3. INSTALLING AND REMOVING THE MODULES

3.1. INSTALLING THE MODULE REAR PLATES

Each module is shipped with a matching rear panel plate which houses the connectors appropriate for the module. When installing a rear plate, locate the desired slot position where you wish to install the rear plate. Make a note of the slot number where you are installing the rear plate. Orient the plate so that the labeling is visible when the plate is installed. Loosely fasten the plate to the extrusions using the mounting screws provided, beginning with the top screw. You will tighten the screws after the main module is installed.

3.2. OPENING AND CLOSING THE FRONT PANEL

In order to insert or remove modules you will have to open the front panel. Turn the two captive screws located on the front panel counter clockwise several turns until they release completely from the front extrusions. Carefully lower the front panel door so that the front edge of the door is lower than the rear of the door.

3.3. INSTALLING THE MODULES

Orient the module vertically such that the white card ejector is on the bottom. Align the card with the card guide corresponding to the slot number where you installed the rear panel plate. Carefully slide the module into the frame and press it completely into the rear panel connectors. Make sure that the connectors are fully seated in the rear panel. When this is done, close the front panel and then tighten the screws that hold the rear panel in place.

3.3.1. Slot Blocker

If you are trying to install a 7800 series module into the 7700FR frame, please review the following information.

Some 7800 series modules require a “slot Blocker” as the card must occupy 2 slots in a 7700FR to ensure that the frame power is managed properly. Please note that not all 7800 series modules come with a slot blocker and therefore they will not fit into the 7700FR. For more information on installing and using a slot blocker, please refer to the individual module chapter of this binder.

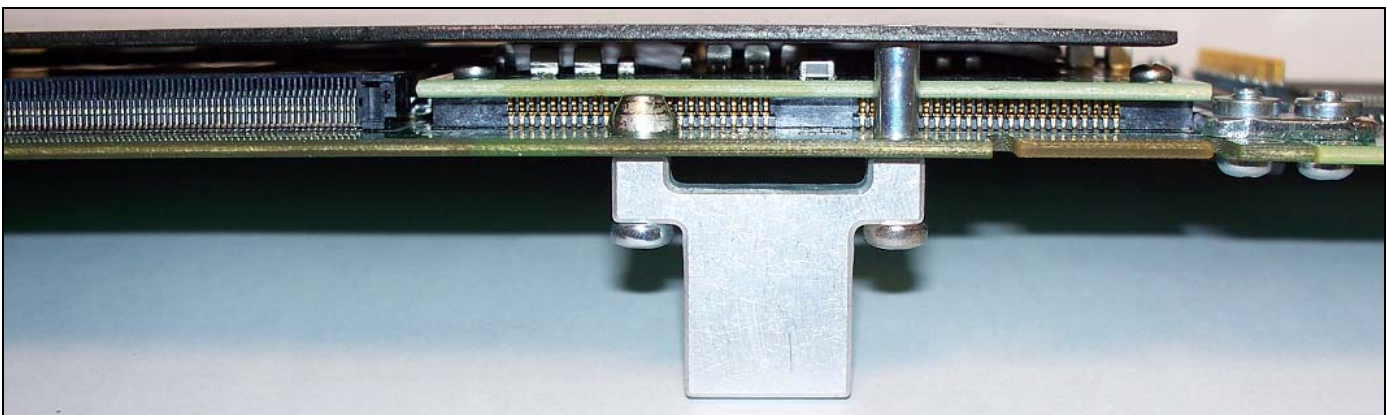

Figure 3-1: Slot Blocker (E7700FR-SLOT-BLOCK)

3.4. REMOVING THE MODULES

Press the card ejector down to release the module. Grasp the card using the card ejector and pull the module out from the frame. As the card ejector goes past the front extrusion, you will have to pull it with slightly more force. Carefully place the module in a safe place, free from static discharge.

4. TECHNICAL DESCRIPTION

4.1. SPECIFICATIONS

4.1.1. Electrical – 350FR Frame

AC Mains Input:	Auto ranging, 100 ⇔ 240 VAC, 50/60 Hz
Maximum Operating Current:	2.6 A (@ 120 VAC), 1.4 A (@ 240 VAC)
Maximum Power Consumption:	130 W
Maximum Module Load:	100 W
Power Supply Configuration:	Dual, redundant, 1 internal, 1 external
Connector:	IEC 60320
Fuse:	2 amp, 250 volt time delay 5 x 20 mm.
Status Indicators:	PSU status LED Local Error/Failure LED
Temperature:	0 - 40°C

4.1.2. Electrical – 350PSX External Power Supply

AC Input Voltage:	Auto-ranging 100 ⇔ 240 VAC, 50/60 Hz
Output Voltage:	+11VDC to 13VDC
Power:	130 W Max

4.2. COMPLIANCE

Safety:	CSA Listed to CSA C22.2 No. 60065-03, UL 60065-03 IEC 60065-(2001-12) 7th Edition Complies with CE Low voltage Directive 2006/95/EC
EMC:	Complies with FCC part 15, class A. Complies with EU EMC directive 2004/108/EC

4.3. PHYSICAL

Height:	5.25" (133 mm)
Width:	8.25" (207 mm)
Depth:	14.5" (368 mm)
Module Capacity:	7 slots
Weight:	Approx. 9 lbs. (4.1 Kg) with power supply, no slots occupied Approx. 16 lbs. (7.25 Kg) with power supply, all slots occupied

5. SERVICING INSTRUCTIONS



CAUTION – These servicing instructions are for use by qualified service personnel only. To reduce the risk of electric shock do not perform any servicing instructions in this section of the manual unless you are qualified to do so.

5.1. CHANGING THE FUSES



Check that the line fuse is rated for the correct value marked on the rear panel. Never replace with a fuse of greater value.

5.1.1. 350FR Frame Power Supply

The fuse holder is located on the rear of the frame, to the left of the XLR power connector. To change the fuse, remove power from the frame. Insert a flat blade screwdriver in the fuse holder and turn it clockwise. Pull out the fuse from the fuse holder using a small screwdriver. Remove the blown fuse and replace with a fuse of the correct value. Use time delay 5 x 20 mm fuses rated for 250 Volts with a current rating of 2 amps (T2AL250V). For your convenience there are spare fuses located in the vinyl pouch in the front of this manual. Carefully reinsert the fuse into the fuse holder. Tighten by turning the fuse holder counter clockwise.

5.1.2. MBL-IIRCBH+AB Anton Bauer Quad Pack

The fuse holder is located below the 28 Volt power outlet. To change the fuses, remove power from the Quad Pack. Insert a flat blade screwdriver in the fuse holder and turn it clockwise. Pull out the fuse from the fuse holder using a small screwdriver. Remove the blown fuse and replace with a fuse of the correct value. Use 10 Ampere 3 AG fuses.

5.2. REPLACING THE POWER SUPPLY

The power supply is a complete assembly and includes the power supply cooling fan and one frame cooling fan. In the event that the power supply or one of the fans malfunction, you will need to replace the power supply assembly with a spare one while the failed assembly is being repaired.

The 350FR power supply is hot-swappable and can be easily replaced from the front without interrupting the signal integrity of the frame, provided you have redundant power connected to the 12 VDC connector. Either the internal or external power supply is capable of supplying full power to the frame by itself, however we recommend running with both supplies powered for power redundancy. The internal power supply is secured into the frame by a machine screw through the rear panel as shown in Figure 5-1. This screw must be removed before the power supply can be extracted from the front.



To reduce risk of electric shock you must replace the mounting screw after replacing the power supply.

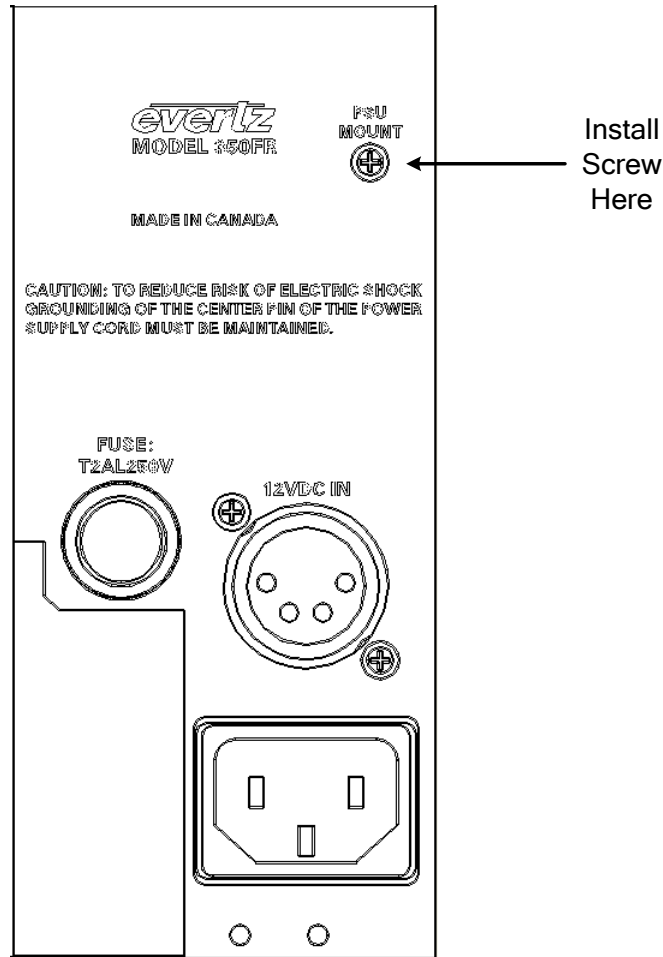
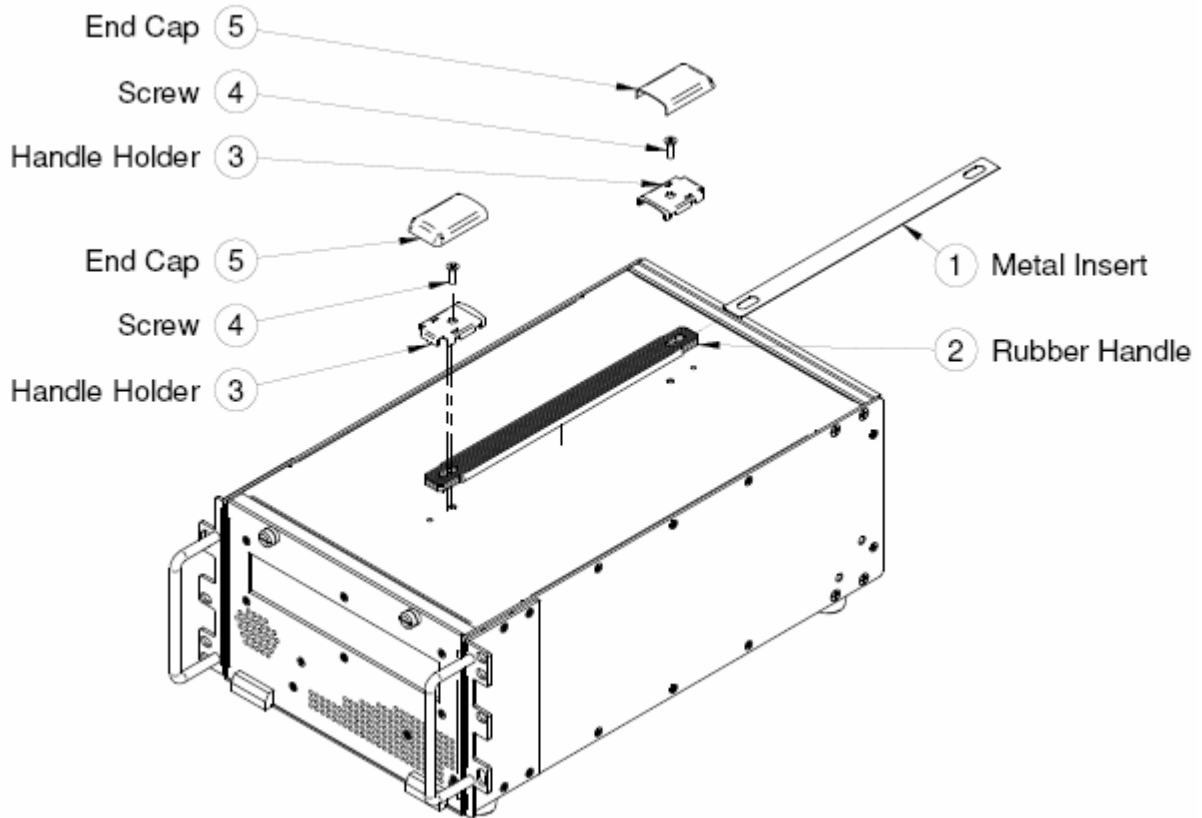

Figure 5-1: Locating the Power Supply Mounting Screw

To replace the power supply the following procedure should be used:

1. Turn off the power supply switch.
2. From the rear of the frame locate the power supply mounting screw. This screw is indicated by the **PSU MOUNT** legend as shown in Figure 5-1.
3. Remove the power supply mounting screw.
4. Open the front door of the frame and pull the power supply out of the frame.
5. Re-insert the new power supply into the frame taking care that it is properly aligned with the card guides. Press firmly to make sure that the power supply is fully seated into the rear panel connector.
6. Re-install the power supply mounting screw from the rear of the frame.
7. Turn on the power switch. After a few seconds you should see the PSU STATUS LED come on indicating that the power supply is working correctly.

5.3. INSTALLING THE PORTABLE CARRY HANDLE AND RUBBER FEET (350FR-PPKIT)**5.3.1. Installing the Portable Carry Handle****Figure 5-2: Portable Carry Handle Installation**

To install the portable carry handle, the following procedure must be used:

1. Lay flat the Rubber Handle/Metal Insert assembly (Items #1 & 2 come pre-assembled) on the top of the unit and align the mounting holes provided.
2. Align the Handle Holder (Item #3) with the holes on the Rubber Handle/Metal Insert assembly. Make sure the Handle Holder alignment pin is aligned with the appropriate hole on the top of the unit.
3. Secure the Handle Holder (Item #3) with the screws provided (Item #4) – 2 pieces
4. Firmly snap in place the End Cap (Item #5) – 2 pieces

5.3.2. Installing the Rubber Feet

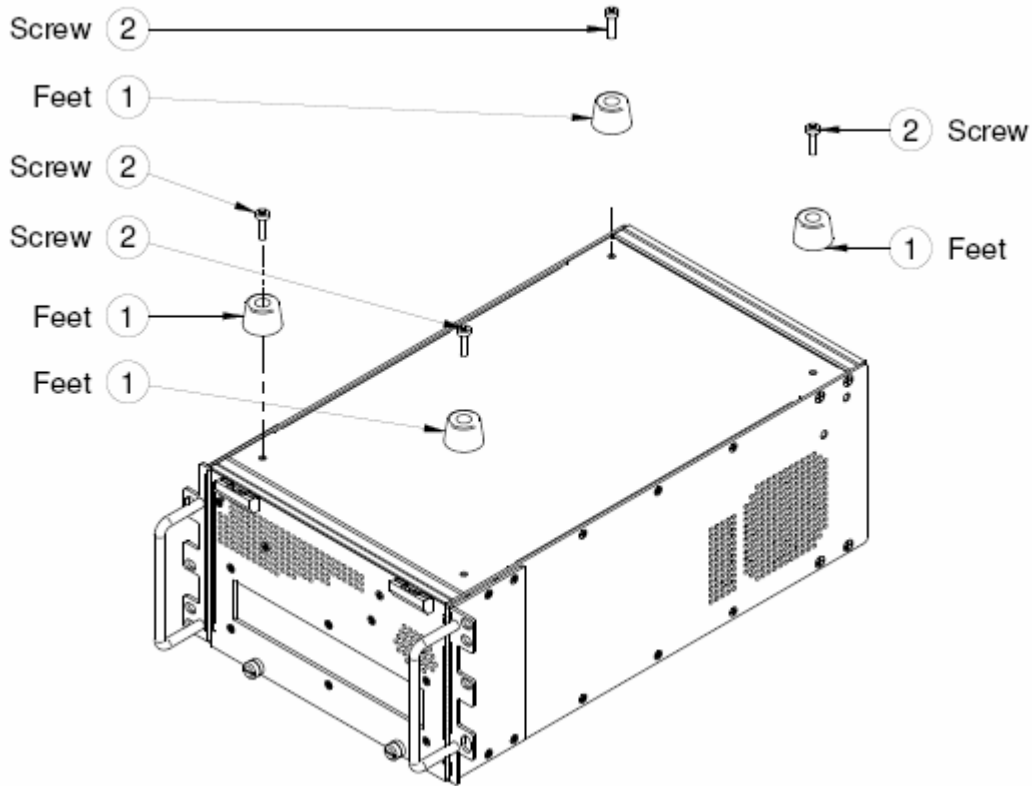

Figure 5-3: Rubber Feet Installation

To install the rubber feet, the following procedure must be used:

1. Carefully turn the unit upside down as shown in Figure 5-3.
2. Align the Feet (Item #1) with the holes on the bottom of the unit – 4 pieces
3. Secure the Feet (Item #1) with the screws provided (Item #2) – 4 pieces
4. Carefully flip the unit back to the upright position.

5.3.3. 350FR-FBB Hermaphroditic Fiber Breakout Bracket Installation



NOTE: 350FR-FBB is compatible with MBL-IRCBP-TAC4-ST Breakout ONLY

350FR TAC FIBER BREAKOUT BRACKET KIT

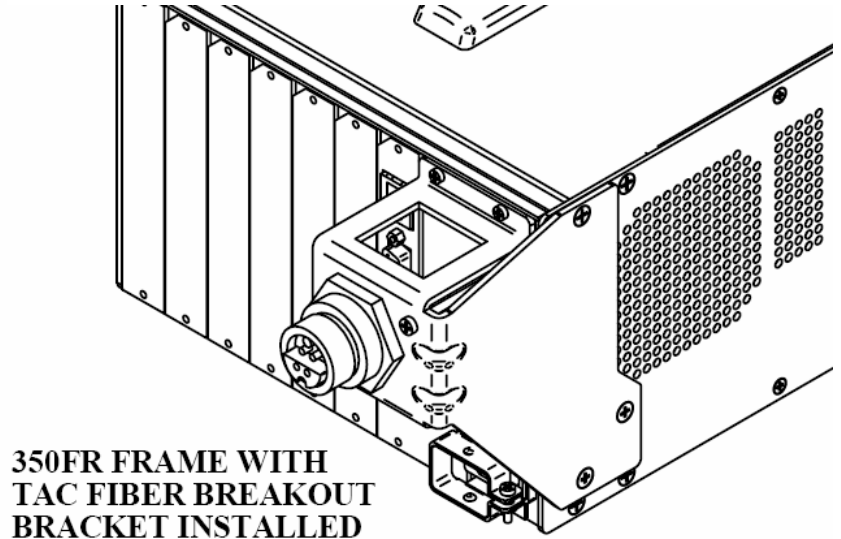
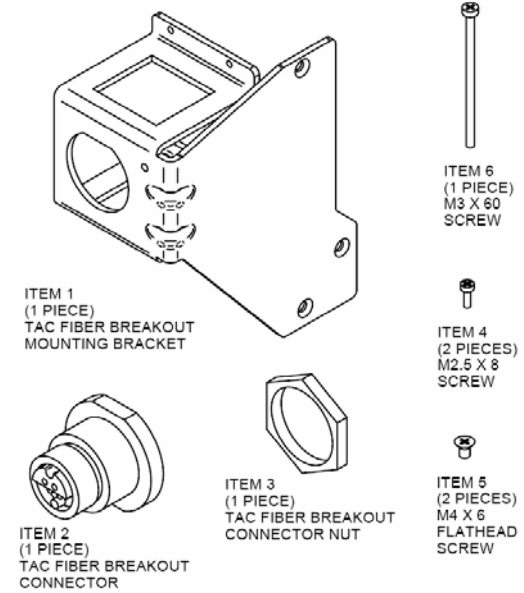

Figure 5-4: Fiber Breakout Bracket Contents and Final Assembly

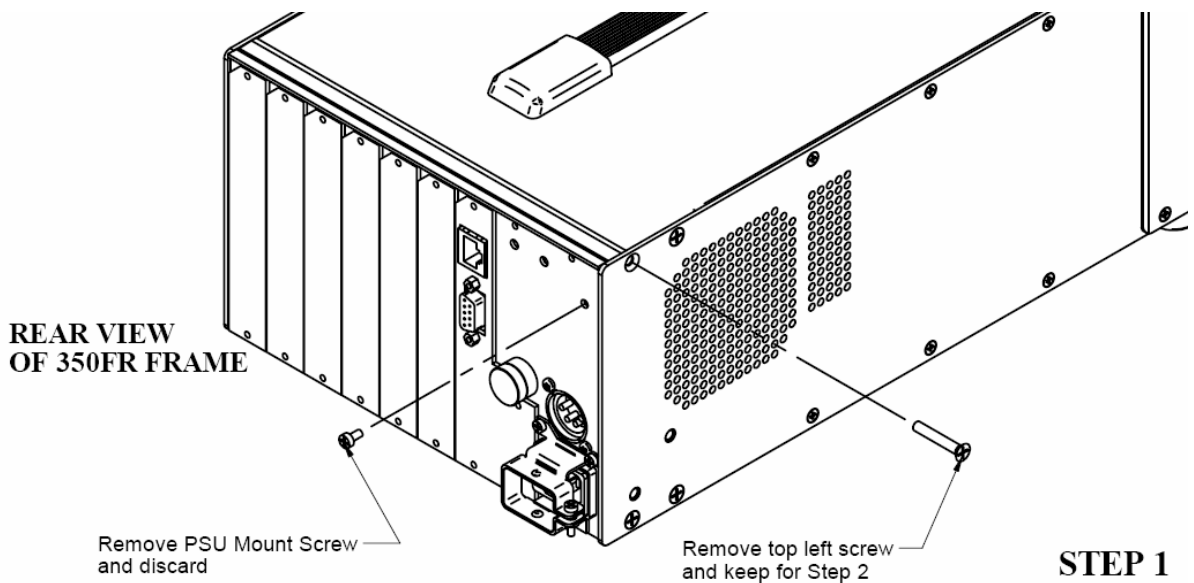
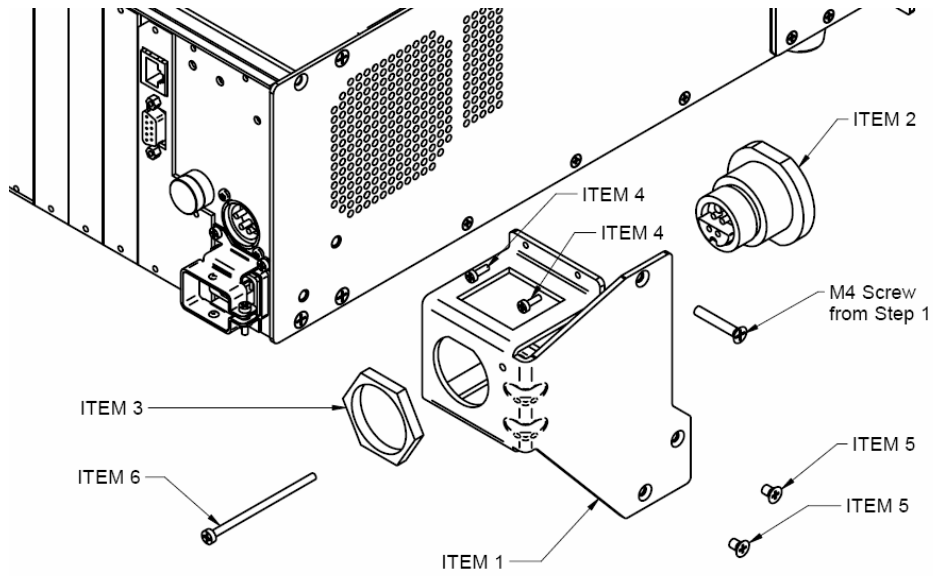

Figure 5-5: Step 1 – Preparing 350FR for Breakout Bracket Installation



STEP 2

Figure 5-6: Step 2 – Attach Fiber Breakout Bracket and Fiber Breakout to 350FR Frame