

3405 Standalone Frame Manual

3405FRS-BNC - Fiber Optic SFP Frame

© Copyright 2011

EVERTZ MICROSYSTEMS LTD.

5288 John Lucas Drive,
Burlington, Ontario, Canada
L7L 5Z9

Phone: +1 905-335-3700

Sales Fax: +1 905-335-3573

Tech Support Phone: +1 905-335-7570

Tech Support Fax: +1 905-335-7571

Sales: sales@evertz.com

Tech Support: service@evertz.com

Web Page: <http://www.evertz.com>

Version 1.1, June 2011

The material contained in this manual consists of information that is the property of Evertz Microsystems and is intended solely for the use of purchasers of the 3405FRS-BNC. Evertz Microsystems expressly prohibits the use of this manual for any purpose other than the operation of the device.

All rights reserved. No part of this publication may be reproduced without the express written permission of Evertz Microsystems Ltd. Copies of this guide can be ordered from your Evertz products dealer or from Evertz Microsystems.

This page left intentionally blank

TABLE OF CONTENTS

1.	OVERVIEW	1
2.	TECHNICAL SPECIFICATIONS.....	3
2.1.	SYSTEM.....	3
2.2.	COMMUNICATION AND CONTROL	3
2.3.	OPTICAL OUTPUT	3
2.4.	OPTICAL INPUT	3
2.5.	COMPLIANCE	3
2.6.	ELECTRICAL INPUTS.....	4
2.7.	ELECTRICAL OUTPUTS	4
2.8.	PHYSICAL	4
2.9.	ELECTRICAL.....	4
2.10.	VSHES34-120300 EXTERNAL POWER SUPPLY BRICK.....	4
3.	MOUNTING	5
3.1.	POWER.....	5
3.1.1.	Connecting a Secondary Power Supply	6
3.1.2.	Power Supply Status Indicators	7
4.	SFP FIBER MODULE INSTALLATION AND REMOVAL	8
4.1.	FIBER INPUT AND OUTPUT CONNECTIONS.....	8
4.1.1.	3405FRS-BNC SFP Module Variants.....	9
4.1.2.	Optical Fiber Handling and Care	10
4.1.3.	Installing an SFP Module	10
4.1.4.	Removing an SFP Module	11
5.	REAR PANEL BNC CONNECTIONS	12
6.	CONFIGURATION AND CONTROL.....	13
6.1.	CONFIGURING THE ON BOARD FRAME CONTROLLER.....	13
6.1.1.	3405 Serial I/O Connections	13
6.1.2.	Terminal Program Setup.....	13
6.2.	3405 FRAME CONTROLLER CONFIGURATION.....	14

6.3.	VISTALINK® CONFIGURATION	15
6.3.1.	General Tab.....	16
6.3.2.	TX/RX Configuration Tabs	18
6.3.2.1.	Tx Configuration.....	20
6.3.2.2.	Rx Configuration	20
6.3.3.	Faults Tab.....	21
6.3.4.	Network Parameter Tab.....	23
6.3.5.	Trap Destination Tab	24
6.3.6.	SFP Monitoring LEDs	24
7.	VISTALINK® MONITORING/CONTROL.....	25
7.1.	WHAT IS VISTALINK®?.....	25
7.2.	VISTALINK® MONITORED PARAMETERS.....	25
7.3.	VISTALINK® TRAPS	26
7.4.	VISTALINK® CONTROLLED PARAMETERS	26

Figures

Figure 1-1: 3405FRS-BNC Frame.....	1
Figure 1-2: 3405FRS-BNC Block Diagram.....	2
Figure 3-1: External Views of 3405FRS-BNC.....	5
Figure 3-2: VSHES34-120300 Power Supply.....	5
Figure 3-3: Locating the External Power Connector.....	6
Figure 3-4: Power Supply Status Indicators.....	7
Figure 4-1: 3405T, 3405R, 3405T13-R, and 3405OO13-DA4 Evertz [®] SFP Modules.....	8
Figure 4-2: 3405FRS-BNC Front View with Fiber Inputs and Outputs.....	8
Figure 4-3: Evertz 3405 Series SFP Module Variants.....	9
Figure 5-1: 3405FRS-BNC Fixed Electrical Connections.....	12
Figure 6-1: 3405T13-2 VistaLINK [®] General Tab.....	16
Figure 6-2: 3405T13-R VistaLINK [®] General Tab.....	16
Figure 6-3: 3405OO13-DA4 VistaLINK [®] General Tab.....	16
Figure 6-4: 3405R-2 VistaLINK [®] General Tab.....	17
Figure 6-5: 3405R-2R VistaLINK [®] General Tab.....	17
Figure 6-6: 3405T13-2 VistaLINK [®] TX Configuration Tab.....	18
Figure 6-7: 3405T13-R VistaLINK [®] TX Configuration Tab.....	18
Figure 6-8: 3405OO13-DA4 VistaLINK [®] RX Configuration Tab.....	19
Figure 6-9: 3405R-2 VistaLINK [®] RX Configuration Tab.....	19
Figure 6-10: 3405R-2R VistaLINK [®] RX Configuration Tab.....	20
Figure 6-11: 3405T13-2 VistaLINK [®] Faults Tab.....	21
Figure 6-12: 3405T13-R VistaLINK [®] Faults Tab.....	21
Figure 6-13: 3405OO13-DA4 VistaLINK [®] Faults Tab.....	22
Figure 6-14: 3405R-2 VistaLINK [®] Faults Tab.....	22
Figure 6-15: 3405R-2R VistaLINK [®] Faults Tab.....	23
Figure 6-16: 3405FRS-BNC VistaLINK [®] Network Tab.....	23
Figure 6-17: 3405FC VistaLINK [®] Trap Destination Tab.....	24

Tables

Table 6-1: Pin Out Description.....	13
Table 6-2: LED Chart.....	24
Table 7-1: VistaLINK [®] Monitoring.....	25
Table 7-2: VistaLINK [®] Traps.....	26
Table 7-3: VistaLINK [®] Controlled Parameters.....	26

REVISION HISTORY

<u>REVISION</u>	<u>DESCRIPTION</u>	<u>DATE</u>
1.0	First Release	Sept 2010
1.1	Updated serial communication pinouts	June 2011

Information contained in this manual is believed to be accurate and reliable. However, Evertz assumes no responsibility for the use thereof or for the rights of third parties, which may be effected in any way by the use thereof. Any representations in this document concerning performance of Evertz products are for informational use only and are not warranties of future performance, either expressed or implied. The only warranty offered by Evertz in relation to this product is the Evertz standard limited warranty, stated in the sales contract or order confirmation form.

Although every attempt has been made to accurately describe the features, installation and operation of this product in this manual, no warranty is granted nor liability assumed in relation to any errors or omissions unless specifically undertaken in the Evertz sales contract or order confirmation. Information contained in this manual is periodically updated and changes will be incorporated into subsequent editions. If you encounter an error, please notify Evertz Customer Service department. Evertz reserves the right, without notice or liability, to make changes in equipment design or specifications.

1. OVERVIEW

The Evertz 3405FRS-BNC Standalone SFP frame is the ideal solution for today's low cost, high density fiber optic distribution needs. The 3405FRS-BNC provides the flexibility needed to handle the high-speed requirements of 3G and HDTV, as well as SD-SDI, SDTi, and DVB-ASI.

The 3405FRS-BNC is designed on a standalone frame to house up to 4 hot swappable Evertz SFP modules. This provides up to 8 EO or 8 OE in a standalone frame. The frame can be configured for a mixture of modules. Refer to the SFP options for more details.

The on-board frame controller provides VistaLINK[®] capabilities for SNMP control and monitoring.

The 3405FRS-BNC frame comes with a primary external power supply module. SFP's and the redundant power supply must be ordered separately. Please refer to the ordering information for more details.

Features:

- Dual Power supplies (primary and redundant)
- Houses up to 4 front loading Evertz SFP modules
- 8 Input/Output BNCs on the rear of unit for electrical connections
- Each slot can be used as an input and an output based on SFP type
- On board Frame Controller for full VistaLINK[®] control and monitoring
- No electrical re-cabling required when hot-swapping modules



Figure 1-1: 3405FRS-BNC Frame

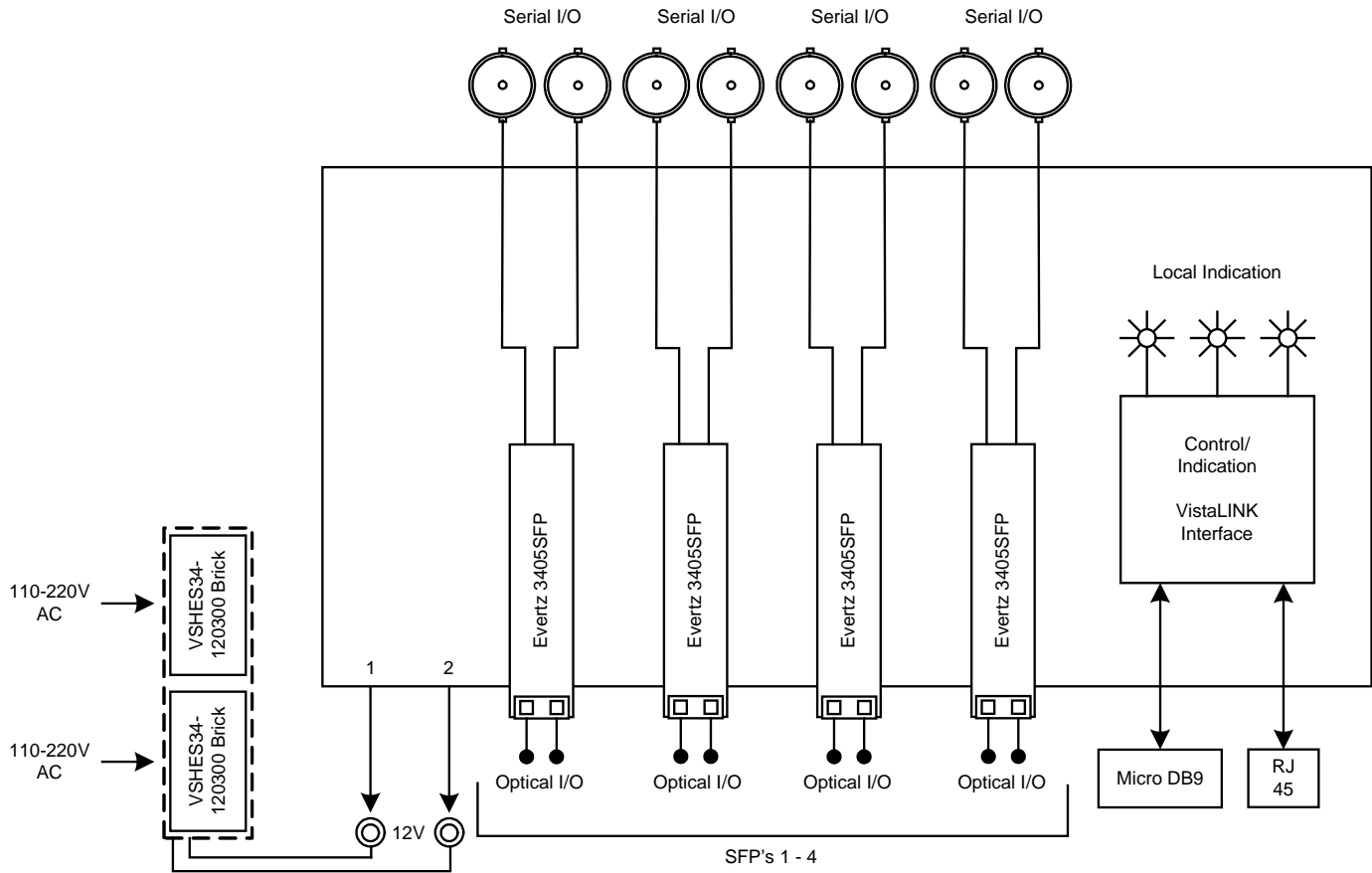

Figure 1-2: 3405FRS-BNC Block Diagram

2. TECHNICAL SPECIFICATIONS

2.1. SYSTEM

Density:	Up to 8 EO, OE, or mixture of EO and OE in a miniature frame
Impedance:	75 Ω
Connector:	BNC per IEC 61169-8 Annex A

2.2. COMMUNICATION AND CONTROL

Serial:	RS-232 single Female 9 pin Micro-D connector
Ethernet:	SNMP over IEEE 802.3/U (10/100 BaseTx) RJ-45 connector
Control:	VistaLINK [®] /SNMP

2.3. OPTICAL OUTPUT

Number of Outputs:	Up to 2 per SFP
Connector:	LC/UPC
Rise/Fall Time:	<270ps
Optical Power:	
Standard:	-1dBm +/- 1dBm
CWDM:	+1dBm +/- 1dBm
Wavelength:	
Standard:	1310nm
CWDM:	1270nm – 1610nm

2.4. OPTICAL INPUT

Number of Inputs:	Up to 2 per SFP
Connector:	LC/UPC
Operating Wavelength:	1270nm to 1610nm
Maximum Input Power:	
Standard:	-1dBm

Optical Sensitivity:	
Standard:	-21dBm at 2.97Gb/s pathological Level A -23dBm at 2.97Gb/s colour bars

2.5. COMPLIANCE

Safety:	CSA Listed, Complies with EU Safety Directive
EMC:	Complies with FCC part 15, Class A Complies with EU EMC Directives

2.6. ELECTRICAL INPUTS

Reclocked Standard:	SMPTE 424M (3Gb/s), SMPTE 292M (1.5Gb/s), SMPTE 259M (270Mb/s), DVB-ASI
Connector:	BNC per IEC 61169-8 Annex A
Equalization:	Automatic to 80m @ 3Gb/s, 100m @ 1.5Gb/s, 250m @ 270Mb/s (with Belden 1694A or equivalent)
Return Loss:	> 15dB up to 1.5GHz > 10dB up to 3GHz

2.7. ELECTRICAL OUTPUTS

Connector:	BNC per IEC 61169-8 Annex A
Impedance:	75 Ω (nominal)
Signal Level:	800mV (nominal)
DC Offset:	0V +/- 0.5V
Rise and Fall Time:	< 135ps (HD/3G) < 900ps (SD)
Overshoot:	< 10% of amplitude
Return Loss:	> 15dB to 1.5GHz > 10dB to 3GHz
Alignment Jitter:	< 0.2UI (Reclocked) to 1.485Gb/s < 0.3UI (Reclocked) to 2.97Gb/s

2.8. PHYSICAL

Dimensions:	1.03" H x 7.08" W x 4.125" D
Module Capacity:	4 Evertz® SFP modules
Operating Temperature:	0-40°C

2.9. ELECTRICAL

Power Supply Configuration:	Dual External Supplies (primary/secondary VSHES34-120300)
Voltage:	DC Input 12V DC (external power supplies required for 110-220V)
Maximum Power Consumption:	12 W (fully loaded frame with all accessories) Note: Power consumption dependent on SFP type
Status Indicators:	PSU status LED

2.10. VSHES34-120300 EXTERNAL POWER SUPPLY BRICK

AC Mains Input:	Auto ranging, 100 \leftrightarrow 240 VAC, 50/60 Hz
Number of Outputs:	1
Output Voltage:	12V DC
Output Connector:	Coaxial power connector
Maximum Power Dissipation:	36 W
Status Indicators:	Green OK LED

3. MOUNTING

The 3405FRS-BNC standalone frame has 4 mounting holes. They are separated 2" vertically, and 6.56" horizontally. To firmly fasten, make sure that all four mounting screws are securely tightened.

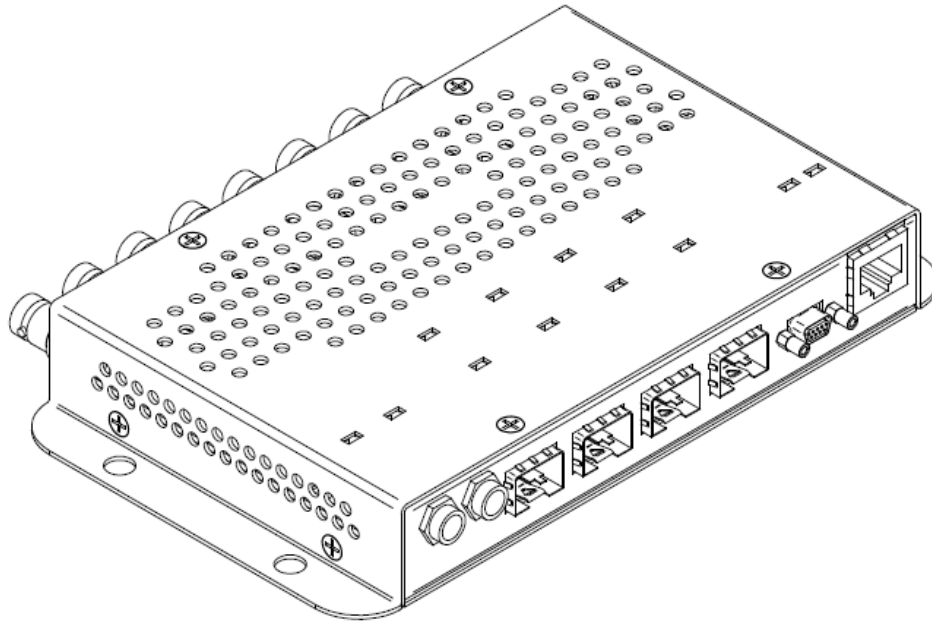

Figure 3-1: External Views of 3405FRS-BNC

3.1. POWER

The 3405FRS-BNC frame requires an auto-ranging external power supply (VSHES34-120300) that automatically senses the input voltage over the range of 110 to 220 VAC. Power should be applied by connecting a coaxial power supply connector cord to the power entry inlet on the front panel (12VDC 1).



Figure 3-2: VSHES34-120300 Power Supply

3.1.1. Connecting a Secondary Power Supply

A redundant power supply is available to provide power in case of a failure in the main power supply.

Power should be applied by connecting a coaxial power supply connector cord to the second power entry module on the front panel (12VDC 2).

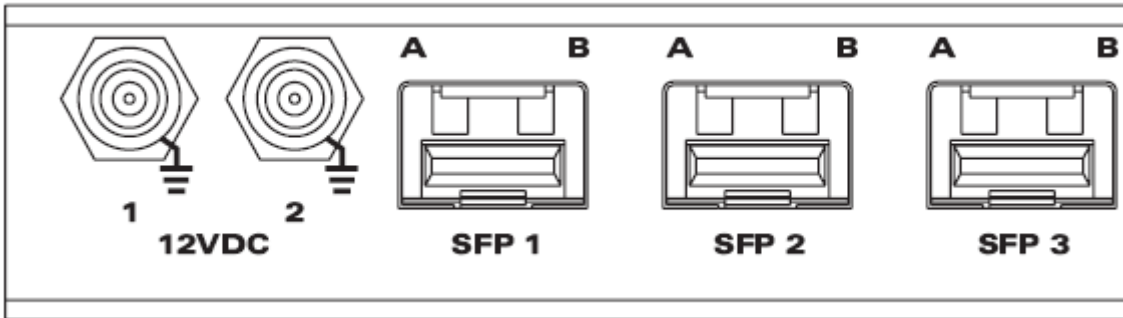

Figure 3-3: Locating the External Power Connector

3.1.2. Power Supply Status Indicators

The 3405FRS-BNC has two power status indicator LEDs. The green PSU STATUS LED indicates the health of the local power supply. The red STATUS LED indicates the health of the entire frame and is operated by the frame status bus. The STATUS LED will be Off under normal conditions and On when there are Frame Status Fault conditions.

If the VSHES34-120300 power supply malfunctions (i.e. power cord disconnected, power switch is off, fuse is blown, etc.) when the VSHES34-120300 redundant power supply is connected, then its STATUS LED will go Off.

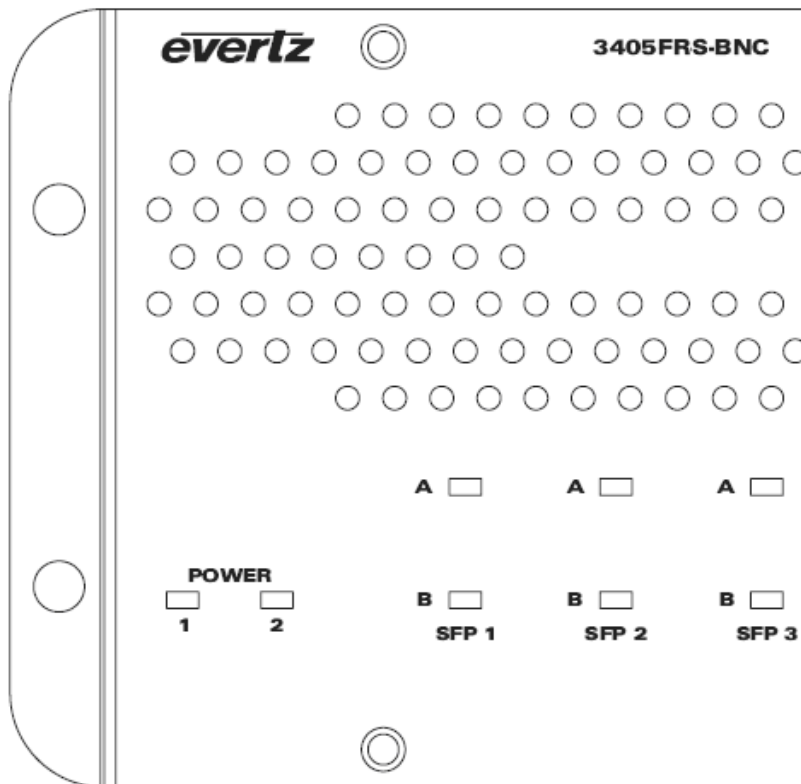

Figure 3-4: Power Supply Status Indicators



The power supplies are short circuit protected and should not blow the fuse under a short circuit condition. If there is a fuse failure, contact Evertz customer service regarding the power supply immediately.



CAUTION: To achieve adequate cooling, care should be taken to ensure that exhaust openings are free of obstructions.

4. SFP FIBER MODULE INSTALLATION AND REMOVAL

Figure 4-1 depicts any one of the following Evertz® SFP modules: 3405T13-2, 3405Txx/yy-2, 3405R-2, 3405R-2R, 3405OO13-DA4, and 3405OOxx-DA4.



Figure 4-1: 3405T, 3405R, 3405T13-R, and 3405OO13-DA4 Evertz® SFP Modules

4.1. FIBER INPUT AND OUTPUT CONNECTIONS

These connections are made using standard LC fiber connector ends, single mode terminated on transmitting ends and multimode terminated on receiving ends. There are a total of 4 dual SFP slots, allowing for a mix of 8 fiber inputs or outputs on the 3405FRS-BNC front panel. A high quality fiber cable such as Corning SMF-28 or suitable equivalents should be used for optimum performance. Compatible SFP modules currently come in four configurations: dual transmitters, dual receivers, reclocking transmitter, and reclocking receiver.

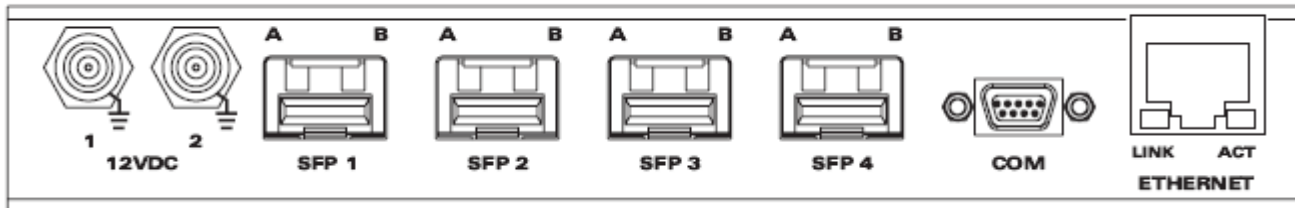

Figure 4-2: 3405FRS-BNC Front View with Fiber Inputs and Outputs

Unpopulated SFP slots will remain inactive until the appropriate SFP is installed. Please ensure flat or ultra flat polished fiber LC connectors are used for the SFPs.



NOTE: Channels A and B on the front of the 3405FRS-BNC frame correspond to channels A and B on the rear of the frame (Figure 5-1).

4.1.1. 3405FRS-BNC SFP Module Variants

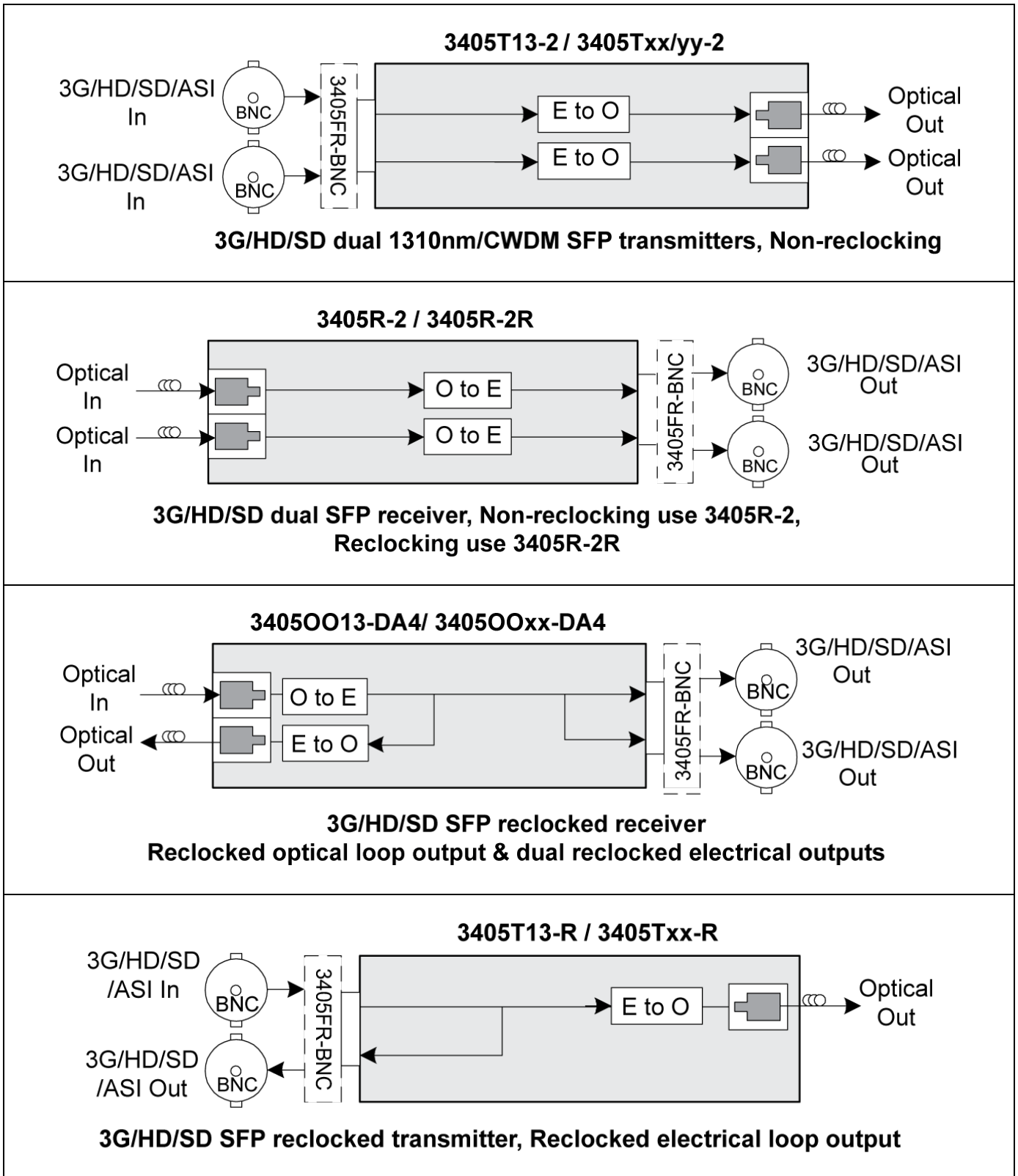

Figure 4-3: Evertz 3405 Series SFP Module Variants

4.1.2. Optical Fiber Handling and Care

The SFP fiber modules are equipped with a class 1 laser and emit invisible radiation. Avoid exposure to the laser emitter and do not stare directly into unconnected SFP emitter ports or fiber ends that are connected to SFP ports.



- It is recommended that trained and qualified personnel install, replace or handle this equipment.
- Ensure ESD precautions are followed during SFP install.
- Store SFP modules in static bags and wear an ESD strap when handling the optical modules. SFP modules are also dust sensitive.
- To prevent dust from entering the apertures of an SFP module, keep plugs inserted into the optical bores.
- Do not repeatedly remove and insert SFP modules more often than necessary. Repeated removals and insertions of an SFP module can shorten its life.

4.1.3. Installing an SFP Module



Note: In most cases, SFP modules will come from the factory preinstalled into its respective slot. The following steps outline the procedure for replacing or installing a new SFP module.

1. Remove the SFP module from its protective packaging. You can identify if your particular SFP module is a duplex transmitter or duplex receiver. Observe the top of the SFP module. The part number is located on the top of the SFP module. A 3405T13-2 or 3405Txx-2 part number denotes a duplex transmitter module (output) and a 3405R-2 and 3405R-2R denotes a duplex receiver module (input). A 3405T13-R part number denotes a reclocking simplex transmitter module (output) and a 3405OO13-DA4 denotes a reclocking simplex receiver module (input).
2. Hold the sides of the SFP module between your thumb and forefinger, position the alignment grooves on the sides of the SFP with the corresponding guides in the SFP slot on your module.
3. Slide the SFP gently but firmly into the SFP slot. You should hear a click when the clips on either side of the SFP snap into place, locking the SFP in the port receptacle.



Note: Do not remove the dust plugs from the optical bores of the SFP or the dust caps from the fiber-optic cable until you are ready to connect the cable. The plugs and caps protect the SFP optical ports and the cable connectors from contamination.

4.1.4. Removing an SFP Module



Note: It is strongly recommended that SFP modules are not installed or removed with fiber-optic cables attached. Doing so may cause damage to the cables, the connectors, or the optical interfaces in the SFP module. Disconnect all cables before removing or installing SFP modules.

1. Pull the bale-clasp latch out and down to eject the module. If the latch is obstructed and you are not able to release the clasp, use a small flat-blade screwdriver or other narrow flat instrument to open the bale-clasp latch.
2. Grasp the SFP module between your thumb and index finger and carefully remove the SFP from its slot.
3. Place the removed SFP module into an anti-static bag, or other ESD protective container.

5. REAR PANEL BNC CONNECTIONS

The BNC's on the rear of the 3405FRS-BNC are fixed and correspond to a particular SFP module. These BNC connectors are agile and thus configured as inputs or outputs. A BNC will become an electrical input if its corresponding SFP spigot is an optical transmitter (Electrical to Optical converter). Conversely a BNC will become an electrical output if its corresponding SFP spigot is an optical receiver (Optical to Electrical converter).

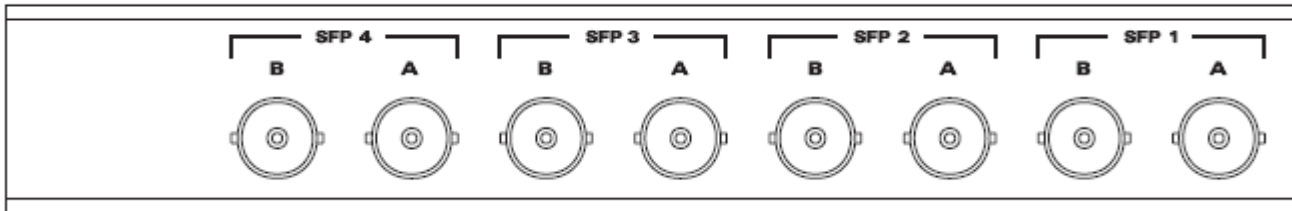

Figure 5-1: 3405FRS-BNC Fixed Electrical Connections



NOTE: Channels A and B on the front of the 3405FRS-BNC frame (Figure 4-2) correspond to channels A and B on the rear of the frame.

6. CONFIGURATION AND CONTROL

The 3405FRS-BNC frame includes an onboard frame controller to provide the ability to communicate with VistaLINK[®]. The onboard frame controller provides a 10Base-T/100Base-TX Ethernet port and communication is facilitated through the use of Simple Network Management Protocol (SNMP). The frame controller handles all SNMP communications between the frame (3405FRS-BNC) and the network manager (NMS), and serves as a gateway to individual SFP's in the frame. The frame controller also provides a custom RS-232 serial port for parameter configurations.

6.1. CONFIGURING THE ON BOARD FRAME CONTROLLER

The on board Frame Controller is configured by connecting its serial port to a computer running a readily available terminal program such as HyperTerminal. The following procedure will guide you through each step of the configuration process.

You will need the following equipment in order to configure the on board Frame Controller

- PC with available communications port. The communication speed is 115200 baud, therefore a 486 PC or better with a 16550 UART based communications port is recommended.
- Terminal program such as HyperTerminal

6.1.1. 3405 Serial I/O Connections

Serial I/O: A 9 pin female Micro DB9 connector for connection to a computer.

Pin #	Name	Description
1	GND	Ground
2		
3	Rx	RS-232 Receive Input
4	Tx	RS-232 Transmit Output
5		
6		
7		
8		
9		

Table 6-1: Pin Out Description

6.1.2. Terminal Program Setup

1. Start the terminal program and configure the port settings of the terminal program as follows:

Baud	115200
Data bits	8
Parity	None
Stop bits	2
Flow Control	None

2. Make the serial connection from female micro DB9 connector of 3405SFR-SFP port labeled COM to the male DB9 connector of the PC.

6.2. 3405 FRAME CONTROLLER CONFIGURATION

This step by step guide will outline all views and set parameters allowed through the serial port.

- 1) From the main menu, there are two selections available:

<<<S-3405 Menu Engine V0.1>>>

- 1- 3405 Controller Settings
- 2- SFP Module Settings

- 2) If menu item #1 *3405 Controller Settings* is selected, the following items will be available:

<<<S-3405 Menu Engine V0.1>>>

- 1- View Network Settings -Displays current network settings
- 2- Change IP Address -Enter new IP Address
- 3- Change Subnet Mask -Enter new Subnet Mask
- 4- Change Gateway Address -Enter new Gateway Address
- 5- Change Broadcast Address -Enter new Broadcast Address
- 6- Controller Firmware Upgrade -Prepares frame for firmware upgrade
- 7- Controller Reboot -Reboots frames
- B- Back -Return to previous menu

- 3) If menu item #2 *SFP Module Settings* is selected, the following items will be available:

<<<S-3405 Menu Engine V0.1>>>

- 1- Slot 1 Settings -Enter settings menu for SFP#1
- 2- Slot 2 Settings -Enter settings menu for SFP#2
- 3- Slot 3 Settings -Enter settings menu for SFP#3
- 4- Slot 4 Settings -Enter settings menu for SFP#4
- B- Back -Return to previous menu



Note that the corresponding slot settings are available only if an SFP is installed in the corresponding slot location

- 4) If a menu item for *Slot 1 Settings* to *Slot 4 Settings* is selected, the following items will be available for the specific SFP option selected:

3405T13-2, 3405Txx-2, 3405T12-R

<<<S-3405 Menu Engine V0.1>>>

- 1- Display SFP Status -Displays SFP status parameters
- 2- Display SFP Serial Number -Displays SFP serial number
- 3- Display SFP Error Message -Displays SFP error message
- 4- Enable/Disable TX Laser Driver -Enable/Disable optical output
- 5- Set TX Laser Automute -Enable/Disable squelch mode
- B- Back -Return to previous menu

3405R2

<<<S-3405 Menu Engine V0.1>>>

- | | |
|------------------------------|---------------------------------|
| 1- Display SFP Status | -Displays SFP status parameters |
| 2- Display SFP Serial Number | -Displays SFP serial number |
| 3- Display SFP Error Message | -Displays SFP error message |
| 4- Set RX Automute | -Sets output squelch mode |
| 5- Set RX Polarity | -Sets output inversion mode |
| 6- Set RX SD/HD | -Sets output slew rate |
| B- Back | -Return to previous menu |

3405R-2R

<<<S-3405 Menu Engine V0.1>>>

- | | |
|------------------------------|---------------------------------|
| 1- Display SFP Status | -Displays SFP status parameters |
| 2- Display SFP Serial Number | -Displays SFP serial number |
| 3- Display SFP Error Message | -Displays SFP error message |
| 4- Set RX Automute | -Enable/Disable squelch mode |
| 5- Set RX Polarity | -Sets output inversion mode |
| 6- Set RX Crosspoint Control | -Sets output swap mode |
| B- Back | -Return to previous menu |

3405OO13-DA4

<<<S-3405 Menu Engine V0.1>>>

- | | |
|-----------------------------------|---------------------------------|
| 1- Display SFP Status | -Displays SFP status parameters |
| 2- Display SFP Serial Number | -Displays SFP serial number |
| 3- Display SFP Error Message | -Displays SFP error message |
| 4- Set RX Automute | -Enable/Disable squelch mode |
| 5- Set RX Polarity | -Sets output inversion mode |
| 6- Enable/Disable TX Laser Driver | -Enable/Disable optical output |
| B- Back | -Return to previous menu |

6.3. VISTALINK[®] CONFIGURATION

The screenshots throughout sections 6.3.1 to 6.3.3 illustrate VistaLINK[®] parameters for the following SFP types: 3405T13-2, 3405T13-R, 3405R-2, 3405R-2R, and 3405OO13-DA4.

6.3.1. General Tab

The “General” tab enables the user to view the status of various parameters such as *SFP Type*, *Serial Number*, and *SFP Firmware Version*.

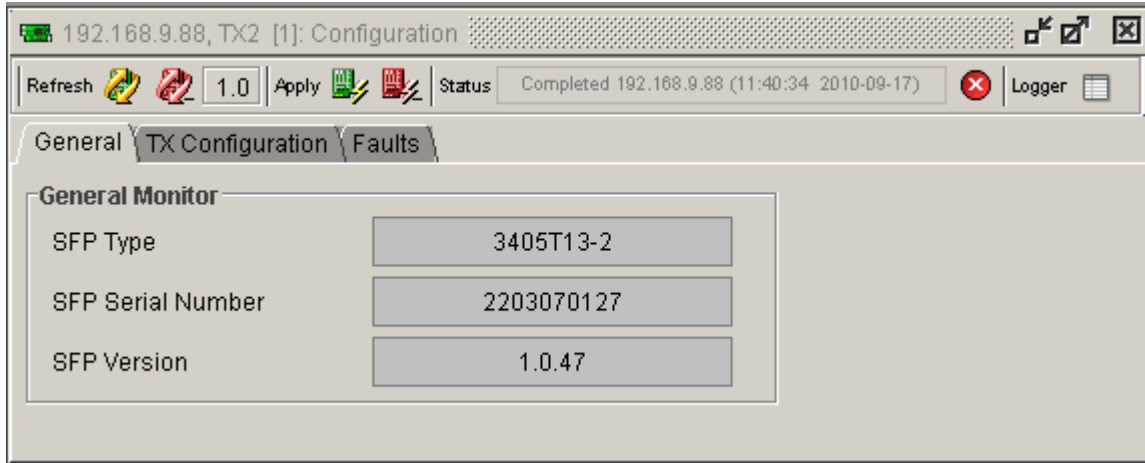

Figure 6-1: 3405T13-2 VistaLINK® General Tab

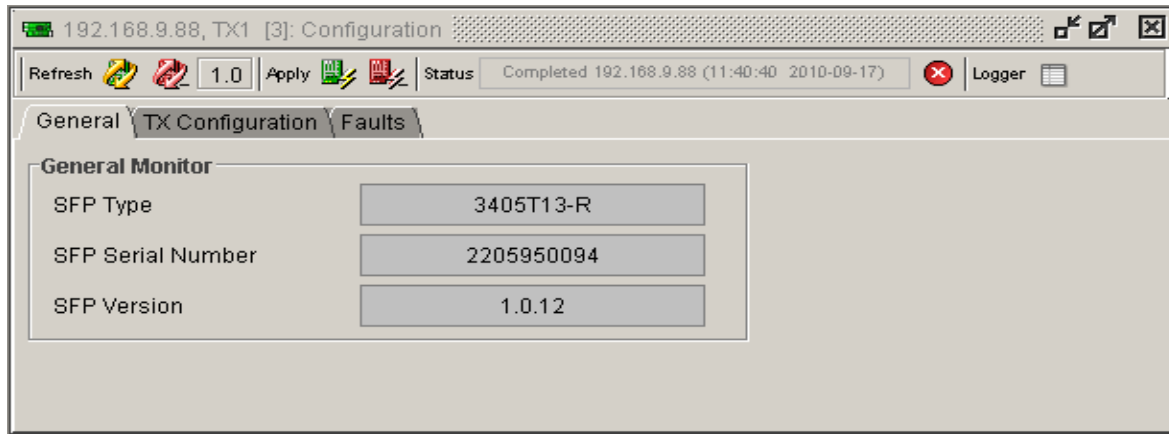

Figure 6-2: 3405T13-R VistaLINK® General Tab

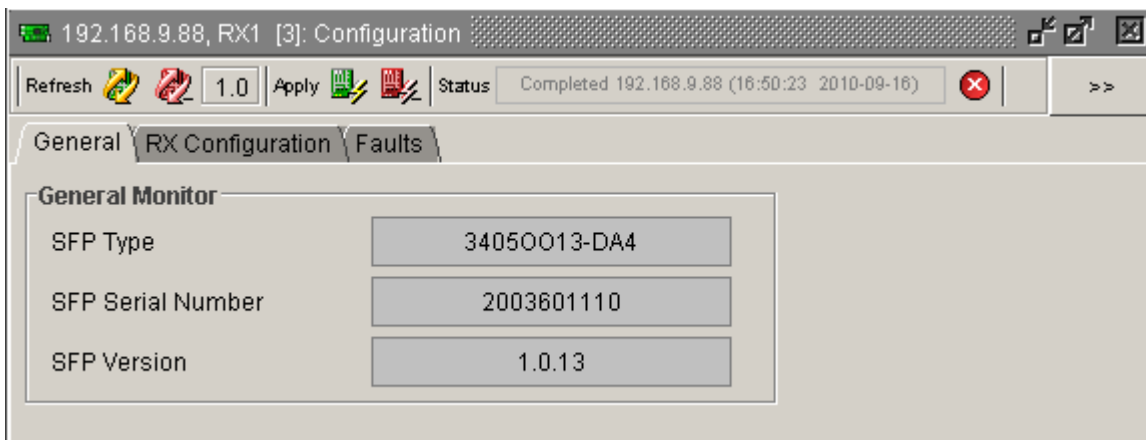

Figure 6-3: 3405OO13-DA4 VistaLINK® General Tab

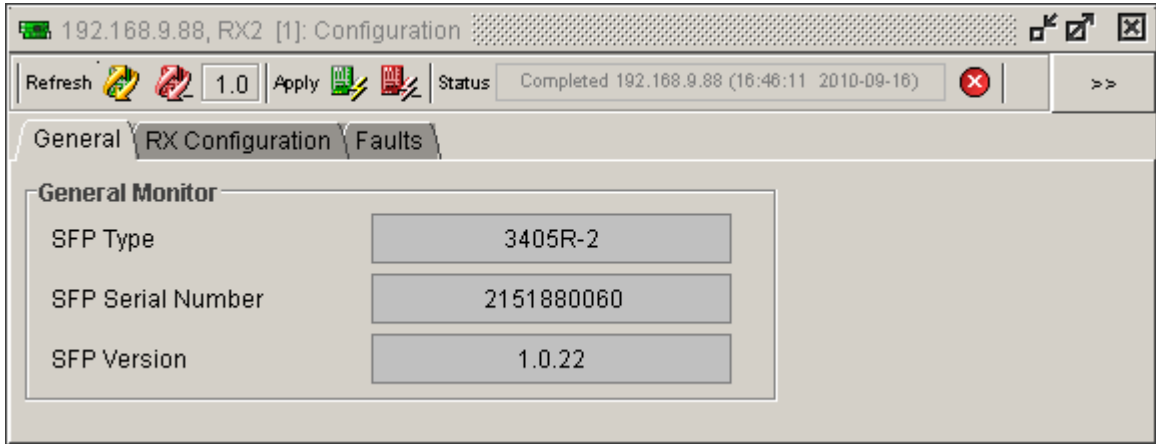

Figure 6-4: 3405R-2 VistaLINK® General Tab

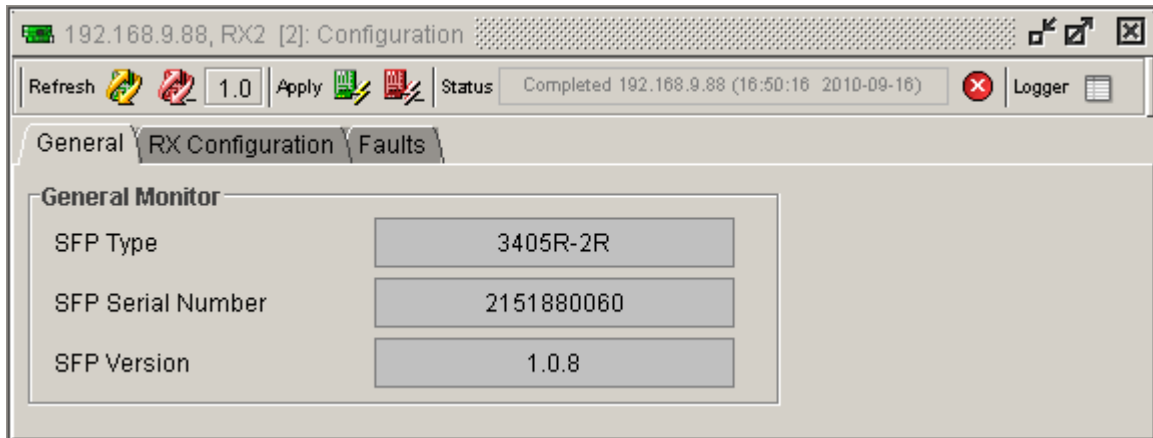

Figure 6-5: 3405R-2R VistaLINK® General Tab

- **SFP Type:** Displays the type of SFP plugged into a particular slot.
- **SFP Serial Number:** Displays the SFP serial number.
- **SFP Version:** Displays the current SFP version number.

6.3.2. TX/RX Configuration Tabs

The “TX Configuration” tab displays the current *Laser Status*, *Wavelength*, *SFP Status*, and *Reclocker Status*. It also allows the user to set *Squelch mode*.

The “RX Configuration” tab displays the *Received Optical Power* and *Reclocker Status*. It also allows the user to set an *Optical Input Power Threshold*, *Inversion mode*, *Slew Rate mode*, *Squelch Mode*, and *Swap Channel mode*.

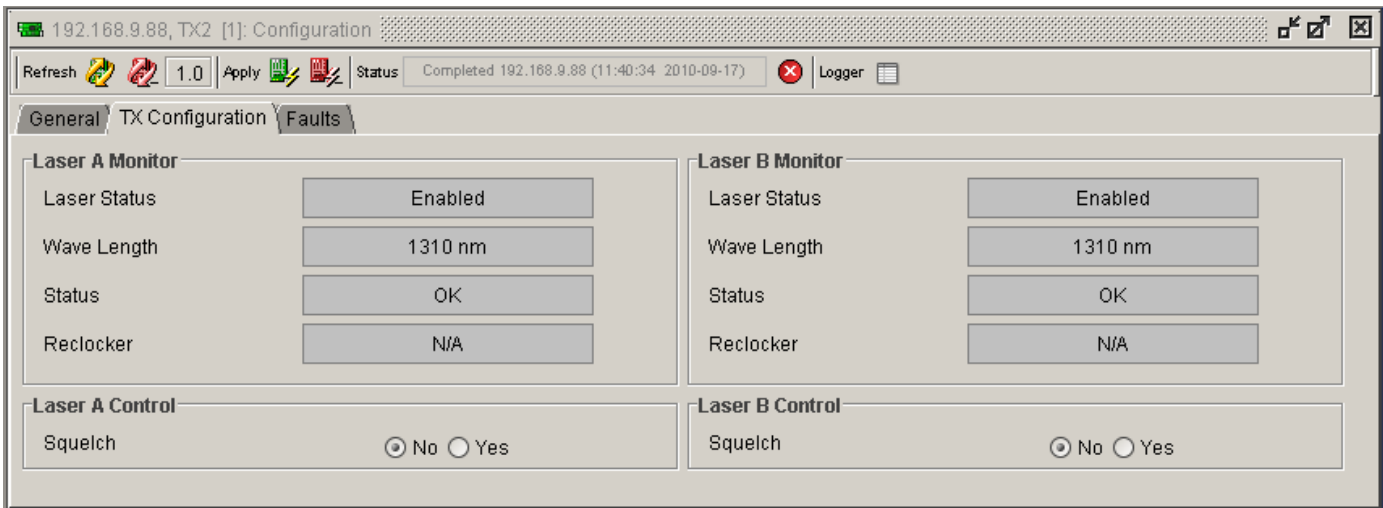

Figure 6-6: 3405T13-2 VistaLINK® TX Configuration Tab

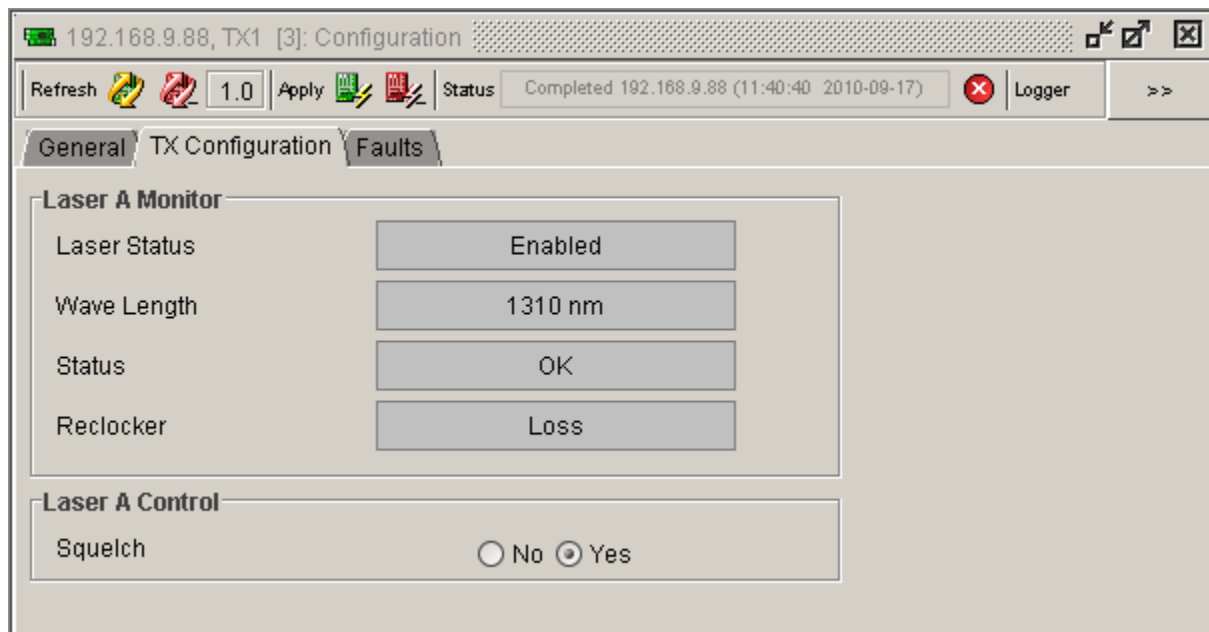

Figure 6-7: 3405T13-R VistaLINK® TX Configuration Tab

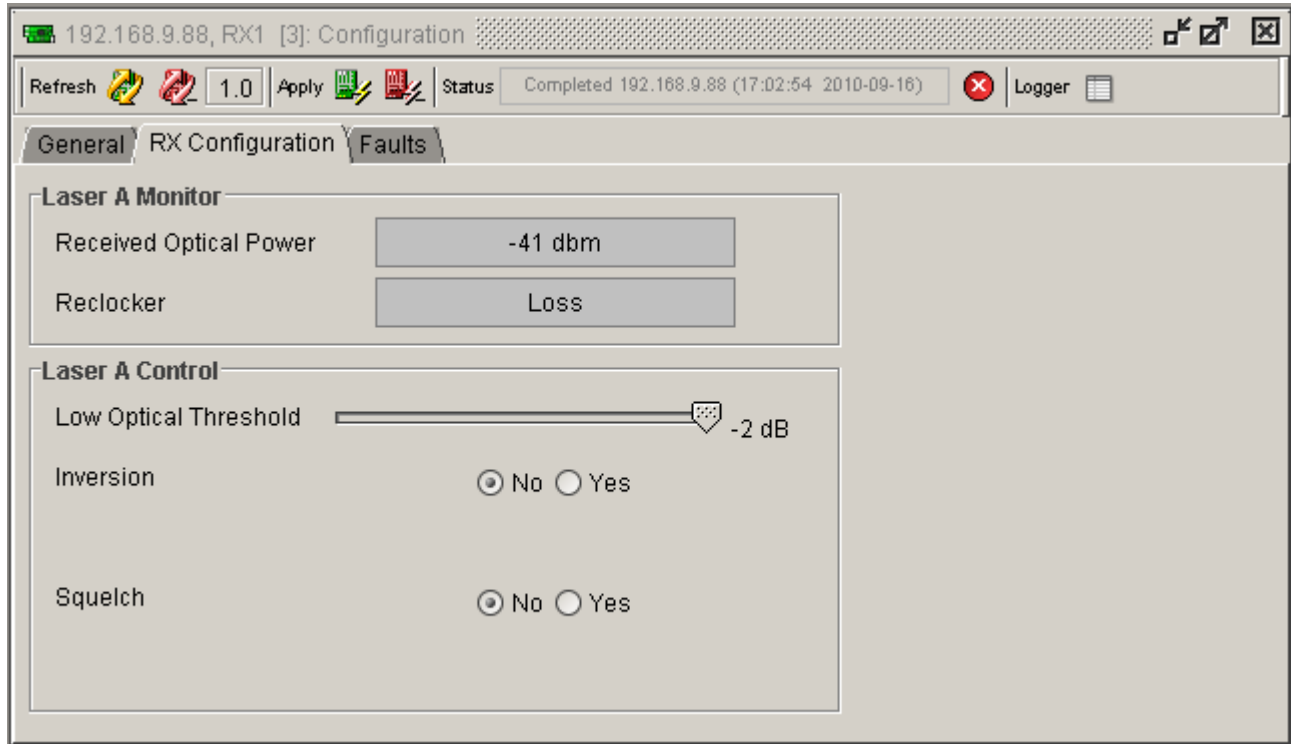

Figure 6-8: 3405OO13-DA4 VistaLINK® RX Configuration Tab

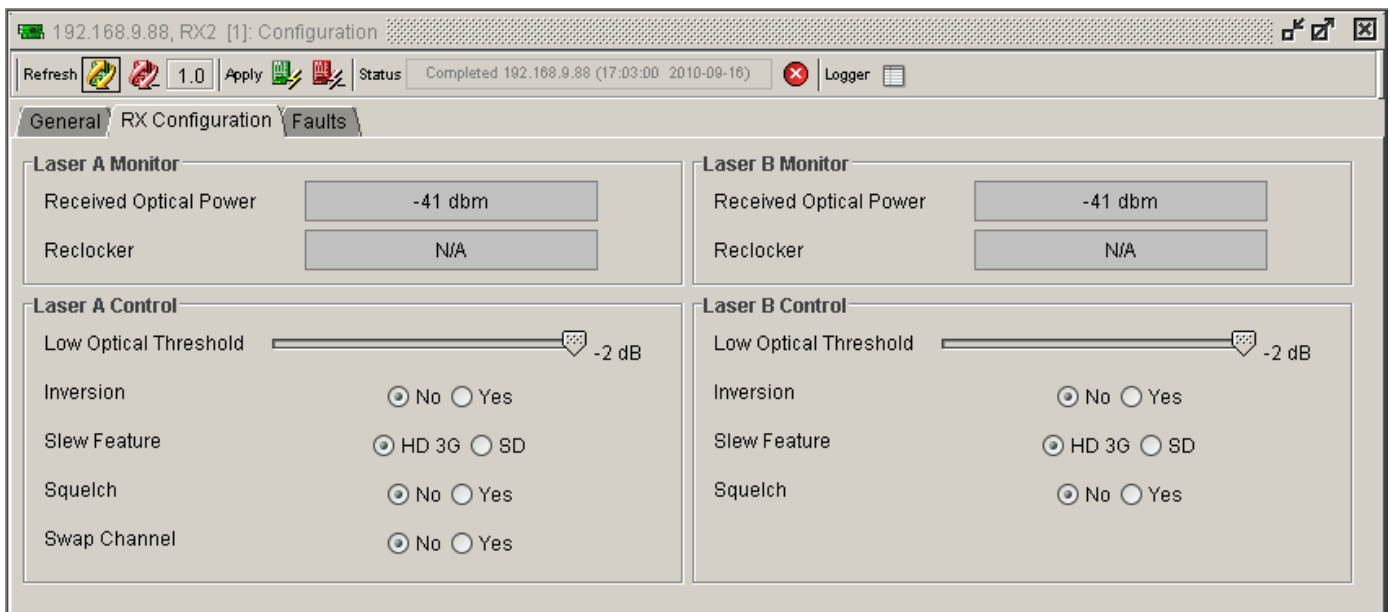

Figure 6-9: 3405R-2 VistaLINK® RX Configuration Tab

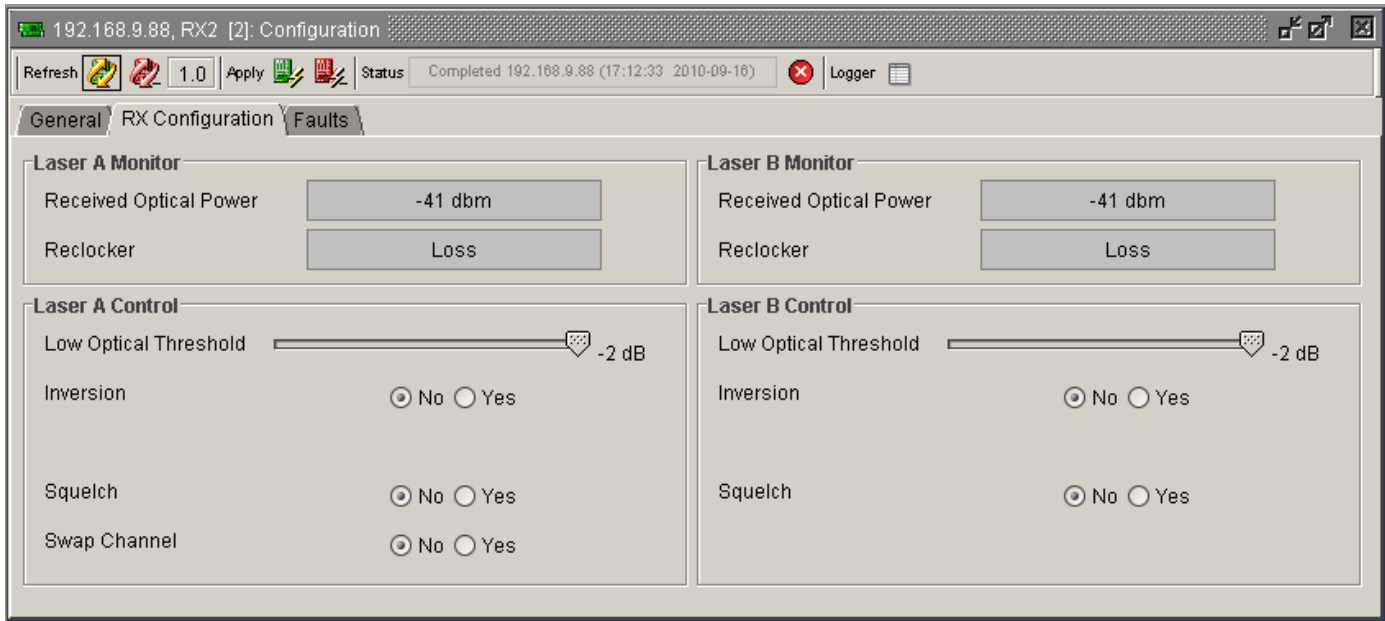

Figure 6-10: 3405R-2R VistaLINK® RX Configuration Tab

6.3.2.1. Tx Configuration

- **Laser Status:** Displays the status of the laser in a SFP transmitter module.
- **Wavelength:** Displays the wavelength of the SFP transmitter.
- **Status:** Displays the general health of the SFP.
- **Reclocker:** Displays the Reclocking Standard if applicable.
- **Squelch:** Sets Squelch Mode.

6.3.2.2. Rx Configuration

- **Received Optical Power:** Displays the optical input power of a SFP receiver.
- **Reclocker:** Displays Reclocking Standard if applicable.
- **Low Optical Threshold:** Sets Low Optical Threshold value.
- **Inversion:** Sets output inversion mode.
- **Slew Feature:** Sets output Slew rate mode.
- **Squelch:** Sets output squelch mode.
- **Swap Channel:** Sets output mapping mode.

6.3.3. Faults Tab

The “Faults” tab allows the user to enable a variety of traps. To enable a particular trap, simply click the box located beside each trap so that a check-mark appears. When a check-mark is present, the trap is enabled. When a check-mark is not present, the trap is disabled.

The *Trap Status* section defines whether a trap is present or missing. If the box is green, then the corresponding trap is present. If the box is red, then the corresponding trap is missing.

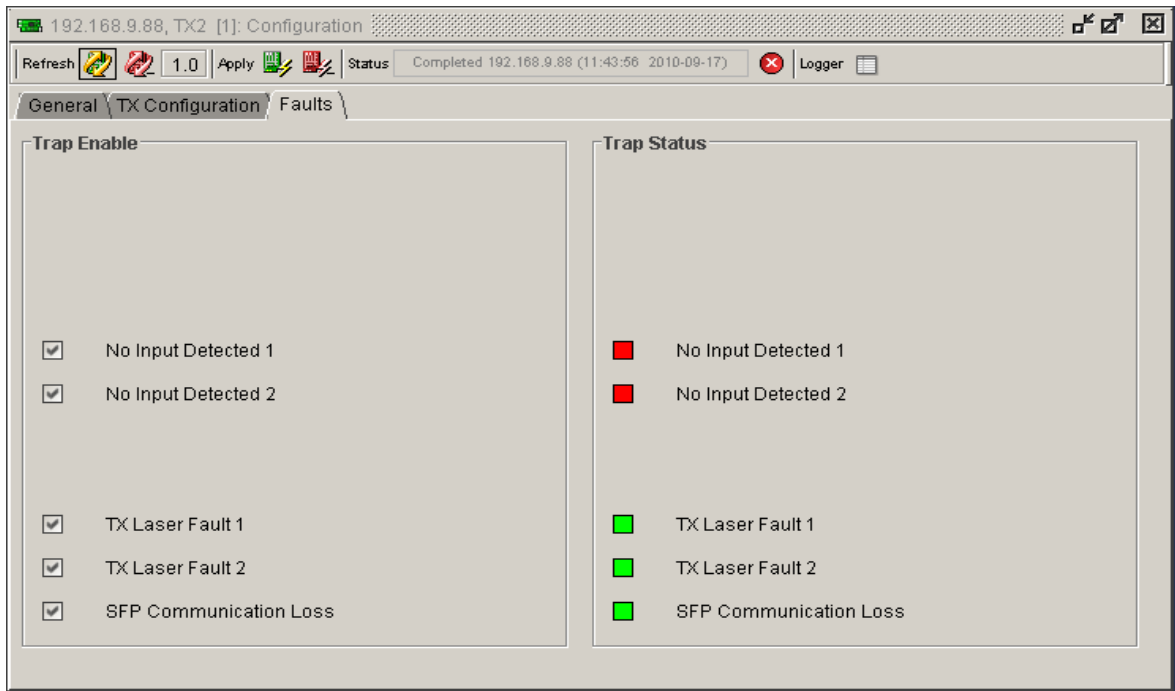

Figure 6-11: 3405T13-2 VistaLINK® Faults Tab

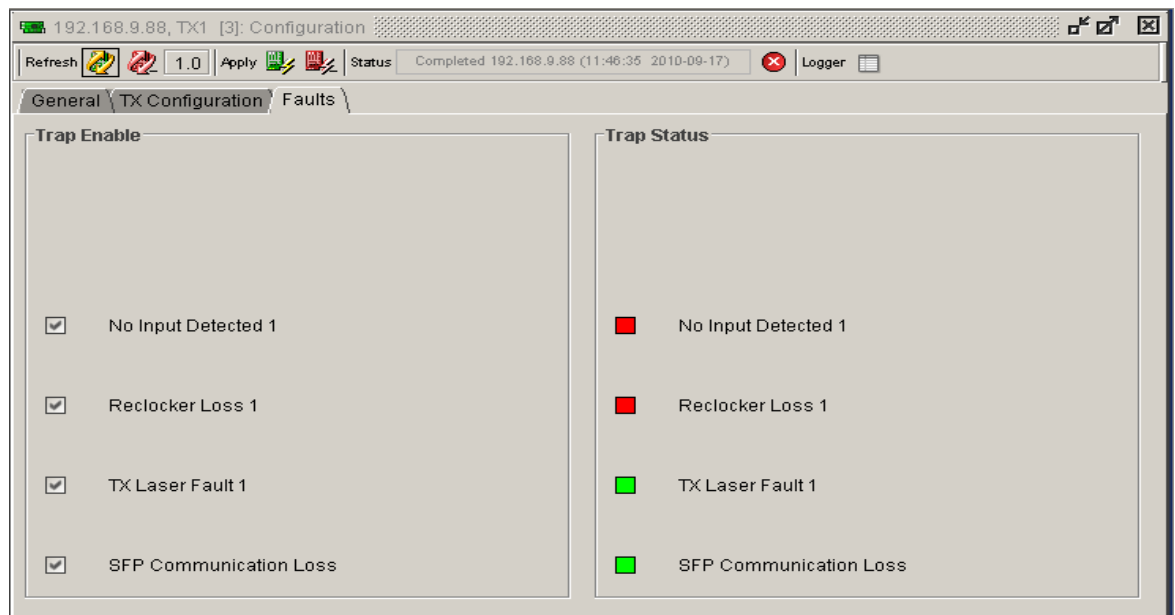

Figure 6-12: 3405T13-R VistaLINK® Faults Tab



Figure 6-13: 3405OO13-DA4 VistaLINK® Faults Tab

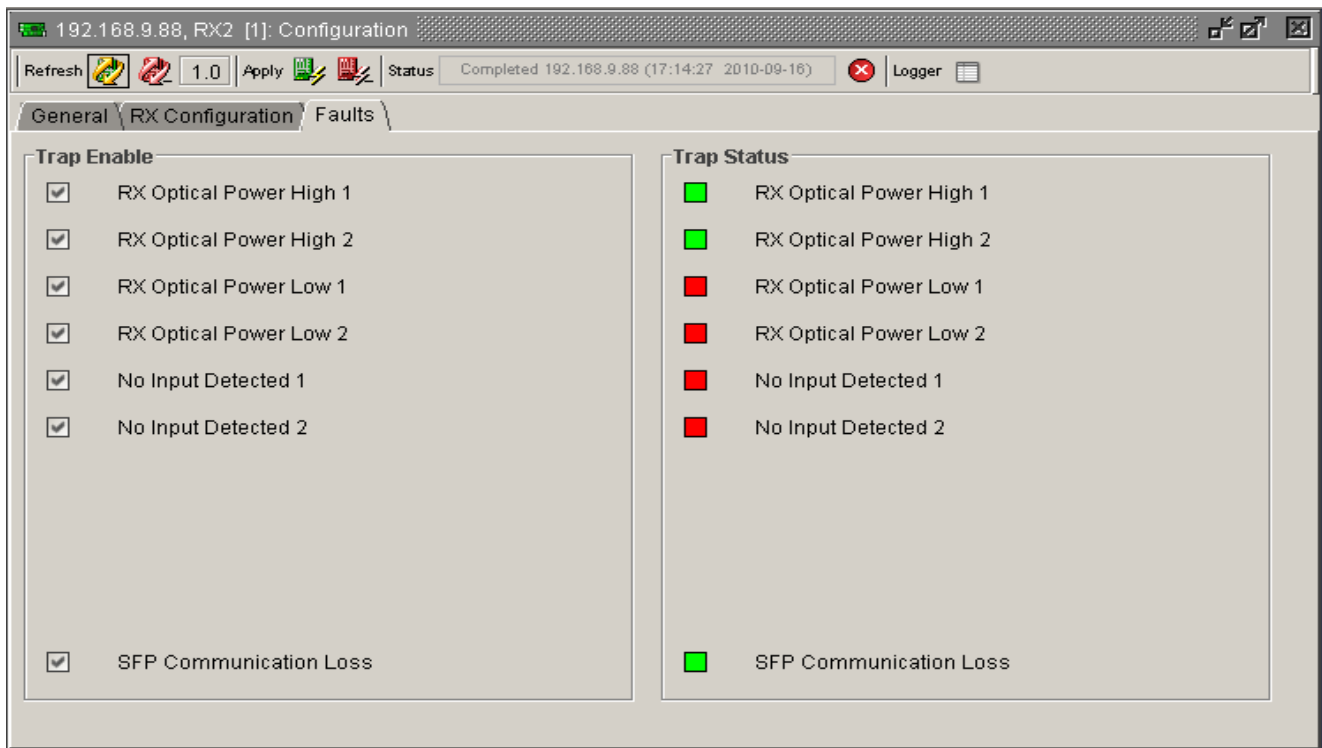

Figure 6-14: 3405R-2 VistaLINK® Faults Tab

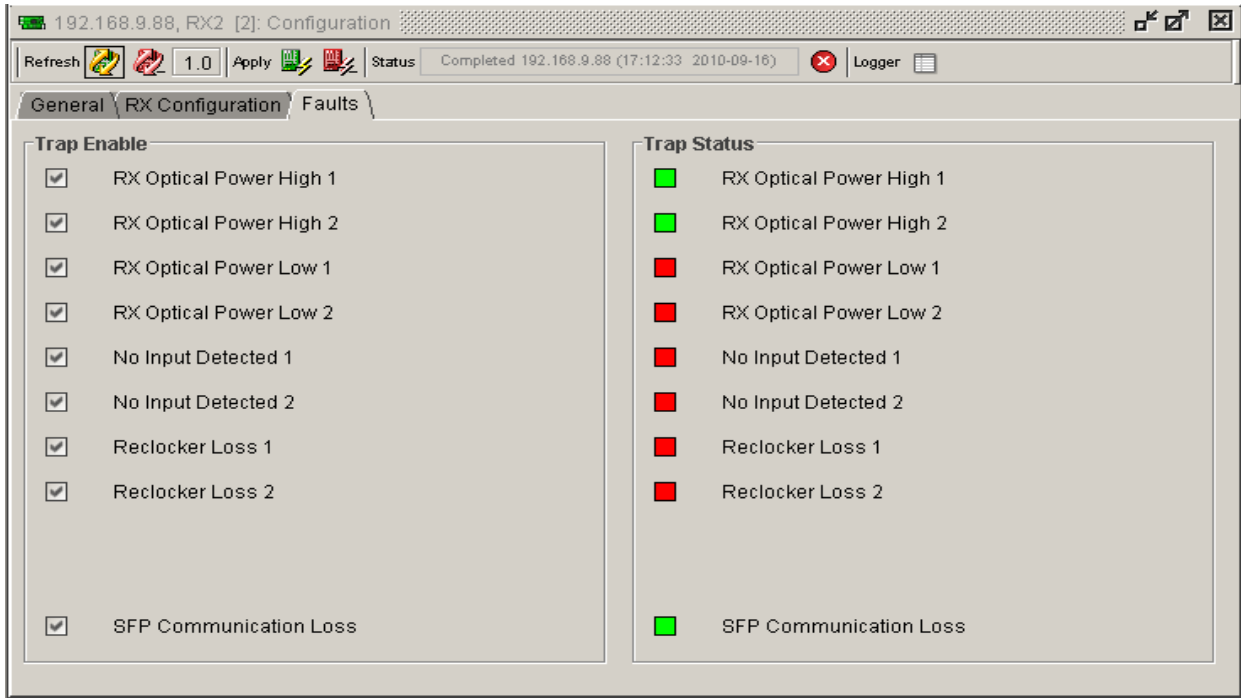

Figure 6-15: 3405R-2R VistaLINK® Faults Tab



The screenshots throughout sections 6.3.4 and 6.3.5 illustrate VistaLINK® parameters for the 3405FRS-BNC.

6.3.4. Network Parameter Tab

The “Network” parameter tab enables the user to define the network parameters of the 3405SFR frame. The *IP Address*, *Subnet Mask*, *Gateway Address*, and *Broadcast Address* can be modified here. Under this tab, there is also an option to reboot the frame.

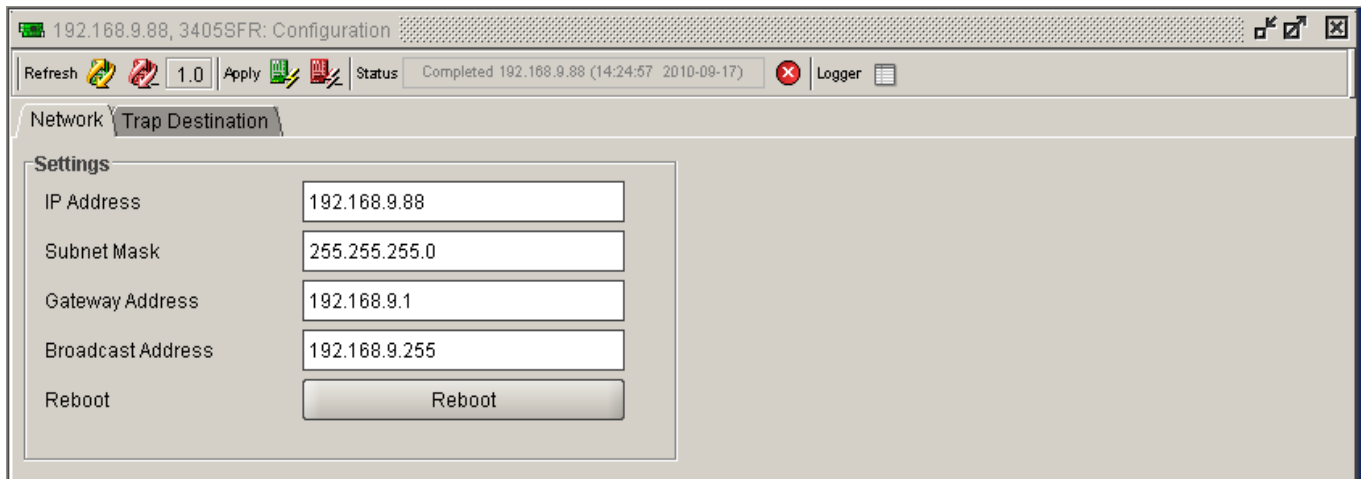

Figure 6-16: 3405FRS-BNC VistaLINK® Network Tab

6.3.5. Trap Destination Tab

The “Trap Destination” tab enables the user to define the IP address of the destination to where SNMP traps will be sent.

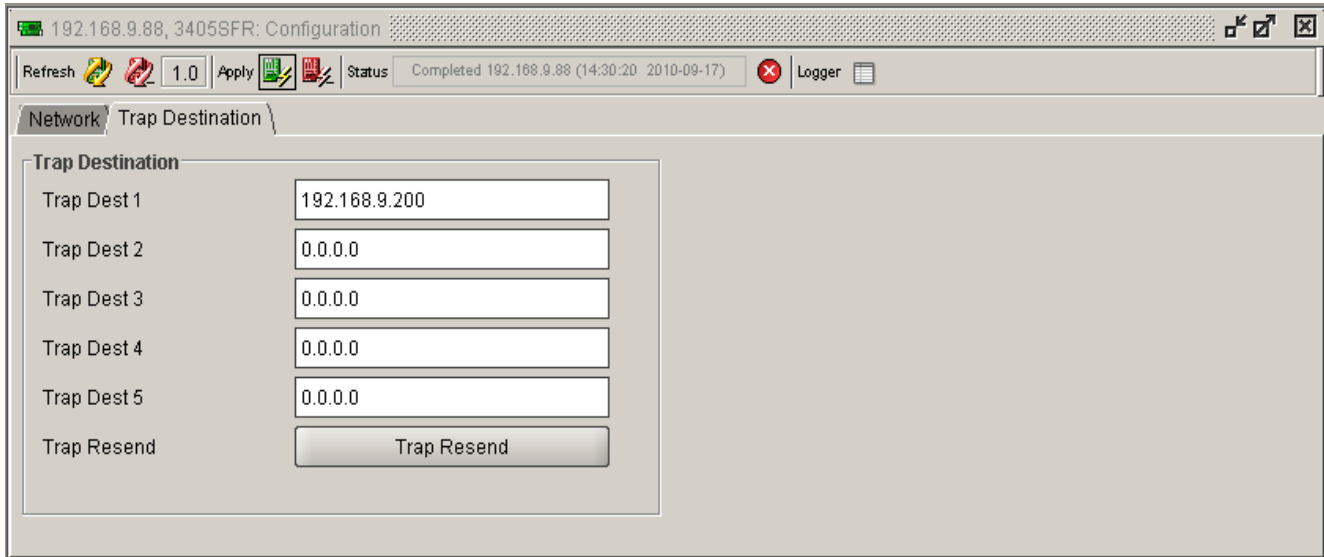

Figure 6-17: 3405FC VistaLINK® Trap Destination Tab

- **Trap Resend:** Select this button to resend the current trap state of the card. All existing traps occurring on the card will be re-broadcast to the VistaLINK® SNMP Client and can be viewed in the trap log.

6.3.6. SFP Monitoring LEDs

The 8 LEDs on the top of the module signify SFP module presence and signal status (1 through 8).

LED	Description
No LED	An unlit LED signifies that the SFP slot is empty. This indicates that there is no SFP plugged into the associated port.
Red LED	Red LEDs indicate the presence of an error with the particular SFP inserted in the corresponding slot number, or it indicates a loss of signal (fiber or coax). This LED indicates that the SFP is Present, but there are errors on the input signal and an input has been unplugged from the SFP.
Green LED	Green LEDs indicate the presence of a working SFP module corresponding to the SFP slot number. Note: Both fiber inputs (for receiver) or both coax inputs (for transmitter) will need to be connected to the SFP. This LED indicates that the SFP is Present, there is a valid signal input, and both inputs are plugged into the SFP.

Table 6-2: LED Chart

7. VISTALINK® MONITORING/CONTROL

7.1. WHAT IS VISTALINK®?

VistaLINK® is Evertz’s remote monitoring and configuration platform which operates over an Ethernet network using Simple Network Management Protocol (SNMP). SNMP is a standard computer network protocol that enables different devices sharing the same network to communicate with each other. VistaLINK® provides centralized alarm management, which monitors, reports, and logs all incoming alarm events and dispatches alerts to all the VLPro Clients connected to the server. Card configuration through VistaLINK® PRO can be performed on an individual or multi-card basis using simple copy and paste routines, which reduces the time to configure each module separately. Finally, VistaLINK® enables the user to configure devices in the network from a central station and receive feedback that the configuration has been carried out.

An SNMP manager, also known as a Network Management System (NMS), is a computer running special software that communicates with the devices in the network. Evertz VistaLINK® Pro Manager graphical user interface (GUI), third party or custom manager software may be used to monitor and control Evertz VistaLINK® enabled products.

7.2. VISTALINK® MONITORED PARAMETERS

The following parameters can be monitored via the VistaLINK® interface.

Parameter	Description
SFP Type	Monitors the type of SFP plugged into a particular slot (TX/RX/OO).
SFP Serial Number	Monitors the SFP serial number.
SFP Version	Monitors the SFP code version.
Received Optical Power	Detects optical input power into each individual SFP receiver.
Reclocker	Detects the reclocking rate of an incoming signal.
Laser Status	Monitors the health of the laser in a SFP transmitter module.
Laser Wavelength	Monitors the wavelength of the SFP transmitter.
Status	Monitors the general health of the SFP.

Table 7-1: VistaLINK® Monitoring

7.3. VISTALINK® TRAPS

The following traps can be enabled and monitored through the VistaLINK® interface.

Parameter	Description
Rx Optical Power High 1	Monitors high optical input on channel 1.
Rx Optical Power High 2	Monitors high optical input on channel 2.
Rx Optical Power Low 1	Monitors low optical input on channel 1.
Rx Optical Power Low 2	Monitors low optical input on channel 2.
No Input Detected 1	Monitors video input on channel 1.
No Input Detected 2	Monitors video input on channel 2.
Reclocker Loss 1	Monitors reclocking status on channel 1.
Reclocker Loss 2	Monitors reclocking status on channel 2.
Tx Laser Fault 1	Monitors laser 1 health.
Tx Laser Fault 2	Monitors laser 2 health.
SFP Communication Loss	Monitors SFP communication with frame controller.

Table 7-2: VistaLINK® Traps

7.4. VISTALINK® CONTROLLED PARAMETERS

The following parameters can be controlled via the VistaLINK® interface.

Parameter	Description
IP Address	Sets IP Address.
Subnet Mask	Sets Subnet Mask.
Gateway Address	Sets Gateway Address.
Broadcast Address	Sets Broadcast Address.
Reboot	Reboots 3405FRS-BNC frame.
Frame Controller Trap Destination	Defines the IP address where SNMP traps will be sent to.
Trap Resend	Resends the current traps state.
Low Optical Threshold	Sets the Input Optical Power Threshold.
Inversion	Sets the Inversion.
Squelch	Sets Output Squelch mode.
Swap Channel	Sets Channel Swap mode.
Slew Feature	Sets Output Slew Rate.

Table 7-3: VistaLINK® Controlled Parameters