

TABLE OF CONTENTS

1. OVERVIEW.....	1
2. INSTALLATION.....	2
3. SPECIFICATIONS.....	3
3.1. ANALOG VIDEO INPUT.....	3
3.2. ANALOG VIDEO OUTPUTS	3
3.3. ELECTRICAL	4
3.4. PHYSICAL.....	4
4. STATUS LEADS.....	5
5. CIRCUIT DESCRIPTION.....	6
6. JUMPERS AND USER ADJUSTMENTS.....	7
6.1. SELECTING WHETHER LOCAL FAULTS WILL BE MONITORED BY THE GLOBAL FRAME STATUS.....	7
6.2. SELECTING THE INPUT AC/DC COUPLING	7
6.3. DC RESTORING (CLAMP) OPERATION	8
6.4. GAIN CONTROL	8
6.5. CABLE EQUALIZATION OPERATION	9
6.6. LOW PASS FILTER SELECTION.....	9
6.7. 501ADA-EQ DIP SWITCH.....	9

Figures

Figure 1-1: 501ADA-EQ Block Diagram.....	1
Figure 2-1: 501ADA-EQ Rear Panel Overlay.....	2
Figure 6-1: LED and Jumper Locations	7

Tables

Table 5-1: Voltage Conditions	6
Table 6-1: DIP Switch Controls	9

REVISION HISTORY

<u>REVISION</u>	<u>DESCRIPTION</u>	<u>DATE</u>
1.0	First Release	May 09

Information contained in this manual is believed to be accurate and reliable. However, Evertz assumes no responsibility for the use thereof nor for the rights of third parties, which may be affected in any way by the use thereof. Any representations in this document concerning performance of Evertz products are for informational use only and are not warranties of future performance, either expressed or implied. The only warranty offered by Evertz in relation to this product is the Evertz standard limited warranty, stated in the sales contract or order confirmation form.

Although every attempt has been made to accurately describe the features, installation and operation of this product in this manual, no warranty is granted nor liability assumed in relation to any errors or omissions unless specifically undertaken in the Evertz sales contract or order confirmation. Information contained in this manual is periodically updated and changes will be incorporated into subsequent editions. If you encounter an error, please notify Evertz Customer Service department. Evertz reserves the right, without notice or liability, to make changes in equipment design or specifications.

1. OVERVIEW

The 501ADA-EQ Equalizing Analog Distribution Amplifier is a general purpose amplifier for distributing analog video signals. The 501ADA-EQ features one balanced equalized input with nine outputs. The 501ADA-EQ amplifier has been designed to distribute a wide range of analog video signals. It can also distribute other pulses and signals that are less than 2Vp-p. The 501ADA-EQ has a user-selectable Low Pass Filter with an 8MHz corner frequency to eliminate unwanted out of band high frequencies.

The 501ADA-EQ is housed in the 500FR **exponent** Frame that will hold up to 16 modules.

Features:

- 75 Ohm or high impedance input (jumper selectable)
- High common mode range and common mode rejection ratio (CMRR)
- Gain control
- Selectable AC or DC coupling
- Selectable fast or slow back porch clamp
- DC level control when clamp is enabled
- Cable equalizer adjustment range: 0 to 300m of 8281 and 1694
- Signal and hardware integrity monitoring
- Over-voltage protection on 12V, +5V, 3.3V power rails
- Under-voltage protection on +5V, -5V and 3.3V power rails

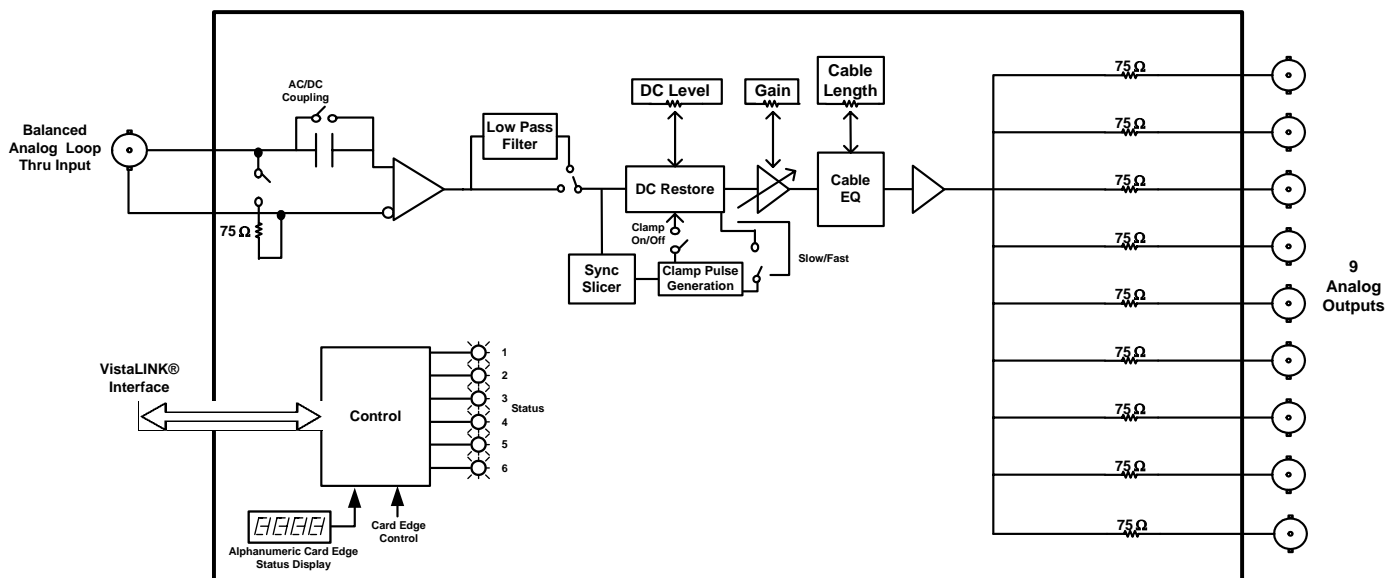

Figure 1-1: 501ADA-EQ Block Diagram

2. INSTALLATION

The 501ADA-EQ comes with a companion rear panel overlay that can be placed over the rear panel BNC connectors to identify their function. For information on inserting the module into the frame see section 3 of the 500FR chapter.

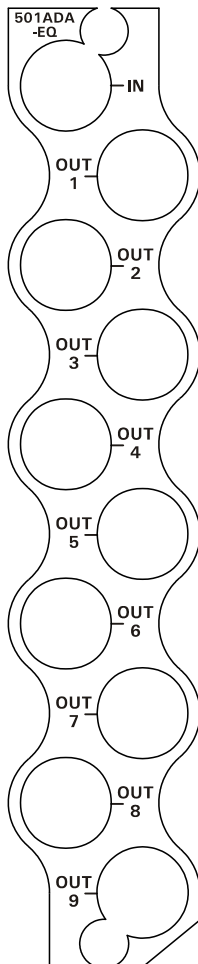

Figure 2-1: 501ADA-EQ Rear Panel Overlay

- IN:** Input (isolated) BNC connector for analog video signals. The INPUT jumper located on the module near the back determines whether the input signal will be 75 Ohm or high impedance. (See section 6.2)
- OUT 1 to 9:** There are nine BNC connectors with equalized, filtered DC level adjusted copies of the input signal.

3. SPECIFICATIONS

Note: At the time of printing, this product has only been qualified for use with standard definition signals. It, however, has been designed to work with high definition signals. Frequency, phase response as well as cable equalization will not be optimized at the upper frequency range of high definition video bandwidths.

All specifications are measured under the following conditions unless otherwise noted:

- 1 Vp-p video applied
- 75 Ohm terminated
- DC coupled
- DC restore clamp turned on with slow time constant
- DC level adjusted for blanking at 0V
- Gain adjusted for unity operation into 75 Ohm load
- Cable equalizer set to 0 length

3.1. ANALOG VIDEO INPUT

Standards:	Any analog video format, up to 2Vp-p and 30MHz bandwidth
Connector:	1 BNC input per IEC 169-8
Common mode range:	>6Vp-p
CMRR:	>70dB to 1kHz
Signal amplitude:	2.5Vp-p max
Cable equalizer:	0 to 300m of Belden 8281 and 1694 cable
Impedance:	35 k Ohms Hi-Z, 75 Ohms terminated
Coupling:	AC or DC
Single Card Return loss¹:	>40dB to 10MHz, >30dB to 30MHz
Clamp range:	>+/- 600mV
Fast clamp attenuation of 60Hz:	>36dB

3.2. ANALOG VIDEO OUTPUTS

Number of Outputs:	9 Per Card
Connector:	BNC per IEC 169-8
Output impedance:	75 Ohm
Gain control range:	± 4dB
DC level	< +/- 100mV (with DC Coupling active and back porch clamp disabled)
DC level Control range:	< +/- 200mV (with back porch clamp enabled)
Single Card Freq. Response²:	
➤ LPF OUT:	< ±0.05dB no equalization (to 8MHz) < ±0.09dB for 5 to 100m Belden 8281 or 1694 (to 8Mhz) < ±0.15dB for 100 to 300m Belden 8281 or 1694 (to 8Mhz)
➤ LPF IN:	< ±0.15dB for 0 m to 300m Belden 8281 or 1694 (to 8MHz) Corner frequency (< -3dB) at 13MHz
Differential Gain:	<0.17 % 0 to 300m

¹ De-rate specs. When looping through multiple 500FR-L-A inputs.

² De-rate spec. by approx. 0.05dB per additional loop-through of other 500FR-L-A inputs.

Differential Phase:	< 0.19 deg 0 to 300m
C/L gain inequality:	<+/-0.1% for all cable lengths
C/L Delay:	
➤ LPF OUT:	<+/-2nsec
➤ LPF IN:	<+/-3nsec
Output isolation:	>42dB to 10MHz, >32 dB to 30MHz
Output return loss:	>40dB to 30MHz
Noise performance:	<-74.5dB RMS NTC7 weighting, <-68dB RMS 15kHz to 5.5MHz

3.3. ELECTRICAL

Voltage:	+ 12VDC
Power:	1.2 Watts

3.4. PHYSICAL

Number of slots:	1
------------------	---

4. STATUS LEADS

The 501ADA-EQ has seven LED Status indicators on the front card edge to show operational status of the card at a glance. Figure 6-1 shows the location of the LEDs.

Two large LEDs on the front of the board indicate the general health of the module:

LOCAL FAULT: This Red LED indicates poor module health and will be On during the absence of a valid input signal, or if a local input power fault exists (i.e.: a blown fuse). The LOCAL FAULT indication can also be reported to the frame through the FRAME STATUS jumper.

MODULE OK: This Green LED indicates good module health. It will be On when a valid input signal is present, and the board power is good.

There are five small LEDs that indicate the status of the input video.

SD/HD Video Presence Indicators: The width of sync is measured to determine if video is present and if it is NTSC/PAL-B or if it is analog high definition video. If sync is approximately 4.7 μ sec wide, the green **SD PRES** LED is illuminated. If sync is approximately 0.6 μ sec wide, the green **HD PRES** LED is illuminated. If neither sync size is present, both LEDs are turned off.

This technique will also successfully detect HD signals with bi-level sync generated by Evertz DACs for applications with computer monitors. Other manufacturers DACs may not have the same sync size so the detection may not work with these signals.

Sync High/Low Indicators: The sync level of the processed video is measured to determine if its amplitude is approximately correct. If sync is below 270mV then the amber **SYNC LOW** LED is turned on and if sync is above 320mV then the amber **SYNC HIGH** LED is turned on. This measurement takes place AFTER all of the card processing. This means that if the card is not calibrated properly, the indicators will not represent the proper state of the video. This includes improper setting of restored DC level, poorly equalized video and wrong gain settings.



These indicators will NOT indicate properly when the input video is AC coupled and the DC restore clamp is turned off.

Video High Indicator: The level of the processed video is measured to determine if its amplitude is approaching the 100% level. If in one field, the video is ever above 700mV then the amber **VIDEO HIGH** LED is turned on for a short duration. If the video is consistently too "hot", then the light will always be on. This measurement takes place AFTER all of the card processing. This means that if the card is not calibrated properly, the indicator will not represent the proper state of the video. This includes improper setting of restored DC level, poorly equalized video and wrong gain settings.



These indicators will NOT indicate properly when the input video is AC coupled and the DC restore clamp is turned off.

5. CIRCUIT DESCRIPTION

The input signal enters the board through a BNC with isolated ground so that balanced input processing may be done to remove any common mode hum that may have been added to the signal and ground shield. On-board jumper allows you to configure the input impedance.

For video applications, the synchronization pulses are analyzed for position and size information. A clamp pulse is generated from the sync information and a clamp signal is delivered to a DC restorer circuit that positions the blanking level to ground. This feature can be enabled, the time-constant of the clamping action may be fast or slow and the DC level may be set.

An adjustable gain stage feeds the cable equalizer that can adjust the frequency response to match the attenuation of up to 300m of coaxial cable. One OP-Amp drives the eight output BNC's with 75-Ohm output impedance.

The digital power supply is separated from the analog power supply. In the case of a failure in the analog power supply, the digital circuitry can report the fault to the global frame status bus and to the frame controller card.

The power supply monitoring circuitry monitors the over-voltage conditions on 3.3V, 5 V and 12V power supplies and under-voltage condition on 3.3V, 5V, and -5V power supplier. When an over-voltage or under-voltage condition is detected, the local fault indicator will be turned on.

	Over-voltage Threshold	Under-voltage Threshold
12V	15.2V	N/A
5V	6.2V	3.6V
-5V	N/A	-3.3V
3V	4.1V	2V

Table 5-1: Voltage Conditions

6. JUMPERS AND USER ADJUSTMENTS

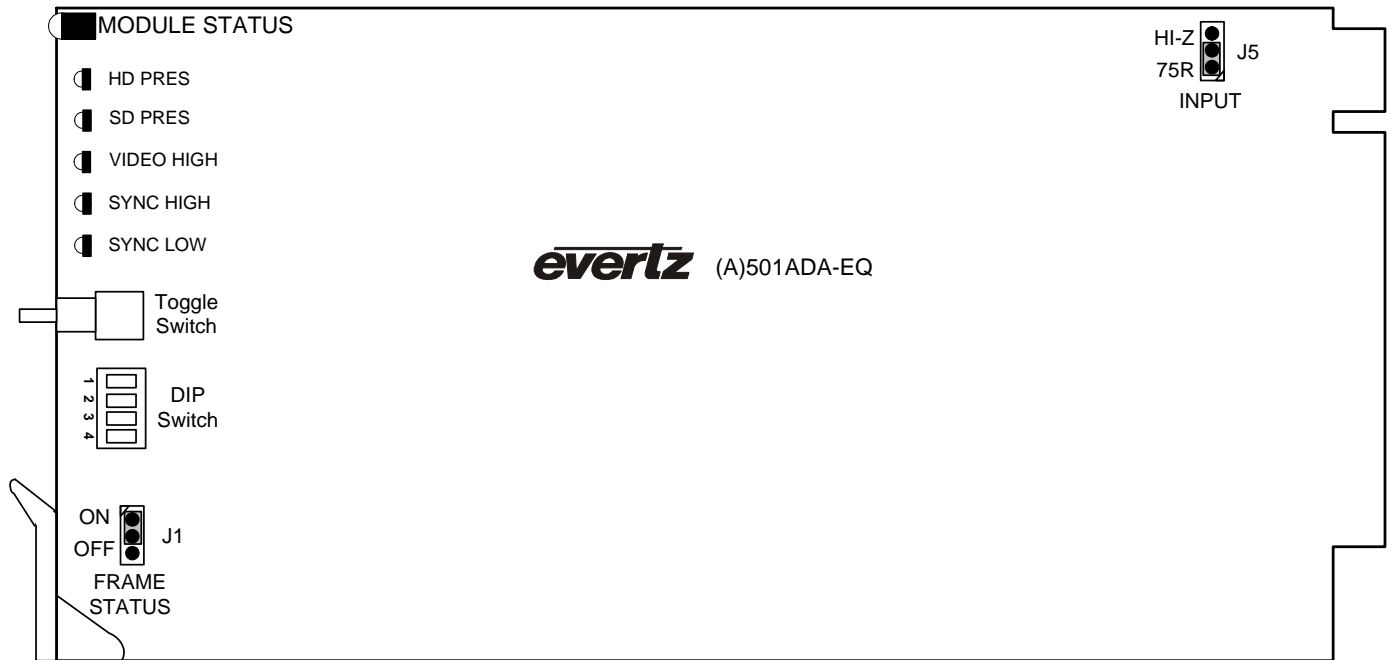

Figure 6-1: LED and Jumper Locations

6.1. SELECTING WHETHER LOCAL FAULTS WILL BE MONITORED BY THE GLOBAL FRAME STATUS

The FRAME STATUS jumper J1, located at the front of the module determines whether local faults (as shown by the Local Fault indicator) will be connected to the 500FR frame's global status bus.

FRAME STATUS: To monitor faults on this module with the frame status indicators (on the power supply's FRAME STATUS LED's and on the Frame's Fault Tally output) install this jumper in the On position.

When this jumper is installed in the Off position local faults on this module will not be monitored.

6.2. SELECTING THE INPUT AC/DC COUPLING

The input may be AC or DC (default) coupled into the input-circuitry. Use AC coupling in applications when the input signal has a large (>2V) DC level. In some non-video applications that do not have DC information (i.e. digital AES audio), AC coupling can be used to remove any DC level that may have built up in its transmission. The DC Restoring (clamp) circuitry will work with either AC or DC coupling in video applications.

6.3. DC RESTORING (CLAMP) OPERATION

A clamp pulse is generated from the sync information and a clamp signal is delivered to a DC restorer circuit that positions the blanking level to ground. This feature will work with standard definition analog NTSC and PAL-B sync structures. Analog tri-level sync 1125-line high definition video (SMPTE 240M) will also be detected and DC restored. In addition, most versions of bi-level sync that have been applied to 1125-line high definition video will be supported.



The clamp position and size will successfully DC restore HD signals with bi-level sync generated by Evertz DACs, for applications with computer monitors. Other manufacturers DACs may not have the same sync size and the DC restoring may not work with these signals.

The clamp action can be enabled, the time-constant of the clamping action may be fast or slow and the DC level may be set. For non-video applications disable the clamp.

For removing low frequency distortions (<1kHz) from clean video, use the clamp time-constant in the FAST position. If the video has a sizeable amount of noise (i.e. a low quality off-air signal) the fast clamp will generate a line-to-line level distortion (also called "piano-keying") because of the noise. In this situation, use the SLOW clamp position. The **CLAMP LEVEL** allows you to adjust the DC level that the back porch is being clamped to. This allows you to set the output DC level to values other than back porch to ground.



Do NOT turn on the clamp when distributing Pb and Pr signals. Standard Definition and High Definition component Pb and Pr signals have waveforms that extend below blanking level. The right level and duration of a negative going video signal may be interpreted as a sync signal, enabling a clamp pulse in active video. This will cause the DC restorer circuit to distort the video, creating a large Average Picture Level (APL) change.

6.4. GAIN CONTROL

The **GAIN** Control allows you to adjust the input signal level.



There is enough range on this control to counteract the video level error due to a missing or double terminated coaxial connection. This will create a frequency response problem due to the mis-termination.

TIP: Set the DC LEVEL before adjusting the gain. The Gain control amplifies the signal around ground. By setting the back porch to ground first, you may avoid re-adjusting the gain.

6.5. CABLE EQUALIZATION OPERATION

With the cable equalizer **EQ Control** set to 0m, the cable equalizer will be set to the "zero length". To set the EQ Control to the correct position, perform the following calibration:

1. Supply the cable being equalized with a multiburst or horizontal sweep test signal.
2. Make sure the driving level from the test generator is calibrated to unity.
3. Make sure the card input termination and the test gear is terminated properly.
4. Adjust the "EQCTRL" until the 501ADA-EQ output signal has flat frequency response.
5. Adjust the DC level if the clamp is enabled and adjust the GAIN level for unity output at low frequencies.

6.6. Low Pass Filter Selection

Low Pass Filter Out/In allows the user to select whether the signal bypasses the low pass filter or not. The low pass filter has a corner frequency of 8MHz with the end of the passband at 8MHz.

6.7. 501ADA-EQ DIP SWITCH

The 501ADA-EQ is equipped with a 4 position DIP switch to allow the user to select various functions. When the DIP switch combinations are selected as shown in Table 6-1, the toggle switch is used to control various parameters. The **closed** position is down, or closest to the printed circuit board. All positions are assigned sequentially such that the first position is located at the top of the DIP switch (farthest from the card ejector).

#	D	I	P	Toggle Switch Function	Control Description Use toggle switch	Range	Default Values
From the top	1	2	3		-----	-----	
0	open	open	open	Gain Control	Adjust Output Level: Up/Left = decrease level Down/Right = increase level	600 – 1600mV	1000mV
1	closed	open	open	EQ Control	Adjust Cable Equalization: Up/Left = decrease level Down/Right = increase level	0 – 300m	0m
2	open	closed	open	DC Level Control	Adjust DC Level of Clamping: Up/Left = decrease level Down/Right = increase level	-200 to 200mV	0mV
3	closed	closed	open	DC/AC Coupling	Set Input Coupling: Up/Left = AC coupling Down/Right = DC coupling	AC DC	DC
4	open	open	closed	Clamp ON/OFF	Enable Clamp Action: Up/Left = clamp OFF Down/Right = clamp ON	CLAMP OFF CLAMP ON	CLAMP ON
5	closed	open	closed	CLAMP Slow/Fast	Set Clamp Time Constant Up/Left = Fast Down/Right = Slow	CLAMP FAST CLAMP SLOW	CLAMP SLOW
6	open	closed	closed	Low Pass Filter Out/In	Select Low Pass Filter Up/Left = In (enable LPF) Down/Right = Out (bypass LPF)	LPF IN LPF OUT	LPF OUT
7	closed	closed	closed	Factory Recall	Hold Up/Left and Down/Right for 3 seconds		

Table 6-1: DIP Switch Controls

This page left intentionally blank