

## TABLE OF CONTENTS

1.	OVERVIEW .....	1
2.	INSTALLATION.....	2
2.1.	7708LRA/7708LR-H CONNECTIONS .....	3
2.2.	CARE AND HANDLING OF OPTICAL FIBER.....	3
2.2.1.	Handling and Connecting Fibers.....	3
3.	7708LRA/7708LR-H SPECIFICATIONS.....	4
3.1.	RF OUTPUT.....	4
3.2.	OPTICAL INPUT.....	4
3.3.	ELECTRICAL.....	4
3.4.	PHYSICAL.....	4
4.	STATUS INDICATORS AND DISPLAYS.....	5
4.1.	7708LRA/7708LR-H STATUS INDICATORS.....	5
5.	JUMPER POSITIONS .....	6
5.1.	7708LRA/7708LR-H JUMPERS .....	6
5.2.	SELECTING WHETHER LOCAL FAULTS WILL BE MONITORED BY THE GLOBAL FRAME STATUS.....	6
5.3.	CONFIGURING THE MODULE FOR FIRMWARE UPGRADES.....	7
5.4.	FACTORY AND BDM JUMPERS .....	7
6.	DOT-MATRIX DISPLAY .....	8
6.1.	7708LRA/7708LR-H CONTROLLED PARAMETERS.....	10
6.1.1.	Adjusting the Optical Power Alarm Thresholds.....	10
6.1.2.	Adjusting the RF Output Power Alarm and Squelch Thresholds.....	10
6.1.3.	Selecting the Output Gain Mode.....	11
6.1.4.	Adjusting the RF Output Gain.....	12
6.1.5.	Adjusting the AGC Target Level .....	12
6.1.6.	Enabling/Disabling Squelch Mode .....	12
6.1.7.	Setting the Card Edge Display Orientation.....	13
6.1.8.	Resetting Factory Defaults .....	13

<b>6.2. TRANSMITTER CONTROLLABLE PARAMETERS .....</b>	<b>13</b>
6.2.1. Adjusting the RF Input Power Alarm Thresholds .....	14
6.2.2. Adjusting the Internal Transmitter Temperature Alarm Thresholds .....	14
6.2.3. Adjusting the Input Voltage Alarm Thresholds .....	14
6.2.4. Adjusting the LNB Current Alarm Thresholds .....	15
<b>6.3. 7708LRA/7708LR-H MONITORED CONDITIONS AND PARAMETERS .....</b>	<b>15</b>
6.3.1. Displaying the Input Optical Power .....	15
6.3.2. Displaying the Output RF Power .....	16
6.3.3. Displaying the Squelch Status .....	16
<b>6.4. TRANSMITTER MONITORED PARAMETERS .....</b>	<b>16</b>
6.4.1. Displaying the Presence of the Data Signal .....	17
6.4.2. Displaying the Input RF Power to the Connected Transmitter .....	17
6.4.3. Displaying the Gain Mode of the Connected Transmitter .....	18
6.4.4. Displaying the Gain Level of the Connected Transmitter .....	18
6.4.5. Displaying the AGC Status of the Connected Transmitter .....	18
6.4.6. Displaying the RF Drive Status of the Connected Transmitter .....	18
6.4.7. Displaying the Output Optical Power of the Connected Transmitter .....	19
6.4.8. Displaying the Laser Status of the Connected Transmitter .....	19
6.4.9. Displaying Status of the Power Supply Connected to the Transmitter .....	19
6.4.10. Displaying the Internal Temperature of the Connected Transmitter .....	20
6.4.11. Displaying the LNB Mode of the Connected Transmitter .....	20
6.4.12. Displaying the LNB Voltage of the Connected Transmitter .....	20
6.4.13. Displaying the LNB Current .....	21
6.4.14. Displaying the Firmware Version of the Connected Transmitter .....	21
6.4.15. Displaying the Model of the Connected Transmitter .....	21
<b>7. VISTALINK® REMOTE MONITORING/CONTROL - 7703 VERSIONS .....</b>	<b>22</b>
<b>7.1. WHAT IS VISTALINK®? .....</b>	<b>22</b>
7.1.1. 7708LRA/7708LR-H VistaLINK® Monitored Parameters .....	23
7.1.2. 7708LRA/7708LR-H VistaLINK® Controlled Parameters .....	23
7.1.3. 7708LRA/7708LR-H VistaLINK® Traps .....	24

**Figures**

Figure 1-1: 7708LRA/7708LR-H Block Diagram .....	1
Figure 2-1: 7708LRA/7708LR-H Rear Panel .....	2
Figure 5-1: Location of 7708LRA/7708LR-H Jumpers and LEDs .....	6
Figure 6-1: Card Edge Menu Structure .....	9

**Tables**

Table 7-1: VistaLINK® Monitored Parameters .....	23
Table 7-2: VistaLINK® Controlled Parameters .....	23
Table 7-3: VistaLINK® Traps .....	24

## REVISION HISTORY

<u>REVISION</u>	<u>DESCRIPTION</u>	<u>DATE</u>
1.0	Initial Release	Feb 09
1.1	Updated specs, other minor updates	May 14

Information contained in this manual is believed to be accurate and reliable. However, Evertz assumes no responsibility for the use thereof nor for the rights of third parties, which may be affected in any way by the use thereof. Any representations in this document concerning performance of Evertz products are for informational use only and are not warranties of future performance, either expressed or implied. The only warranty offered by Evertz in relation to this product is the Evertz standard limited warranty, stated in the sales contract or order confirmation form.

Although every attempt has been made to accurately describe the features, installation and operation of this product in this manual, no warranty is granted nor liability assumed in relation to any errors or omissions unless specifically undertaken in the Evertz sales contract or order confirmation. Information contained in this manual is periodically updated and changes will be incorporated into subsequent editions. If you encounter an error, please notify Evertz Customer Service department. Evertz reserves the right, without notice or liability, to make changes in equipment design or specifications.

## WARNING

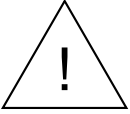

***Do not*** connect the 7708LRA without optical attenuation to a transmitter producing in excess of +5dBm optical power. Maximum optical input to the 7708LRA is +5dBm – more power than this may damage the receiver.



***Do not*** connect the 7708LR-H without optical attenuation to a transmitter producing in excess of -7dBm optical power. Maximum optical input to the 7708LR-H is -7dBm – more power than this may damage the receiver.

## 1. OVERVIEW

The 7708LRA/7708LR-H Fiber Optic Receiver is used for receiving L-Band signals transported optically over fiber optic cable by a companion transmitter. It accepts a single optical input and provides dual electrical outputs. It is also capable of decoding and displaying monitoring data sent by compatible Evertz L-Band transmitters, with SmartMON™ capability. The 7708LRA uses a standard sensitivity optical receiver, while the 7708LR-H uses a high-sensitivity receiver to achieve longer distance links.

The 7708LRA/7708LR-H occupies one card slot and can be housed in a 1RU frame which will hold up to three modules, a 3RU frame which will hold up to 15 modules or a standalone enclosure that will hold a single module.

### Features:

- Wide frequency passband
- Protocol transparent - handles all video, audio and data modulation formats
- Fully hot swappable from front of frame
- Available in SC/UPC, SC/APC, ST/UPC, FC/UPC and FC/APC connector options
- Supports multi-mode and single-mode fiber optic cable
- Comprehensive signal and card status monitoring via four-digit card-edge display, or remotely through SNMP and VistaLINK® capability
- Manual and automatic gain control modes
- Unique IGC mode compensates for optical loss and provides an output signal level proportional to the input, with adjustable gain
- Two RF outputs for extra signal distribution or monitoring functions
- Three user selectable output RF gain settings

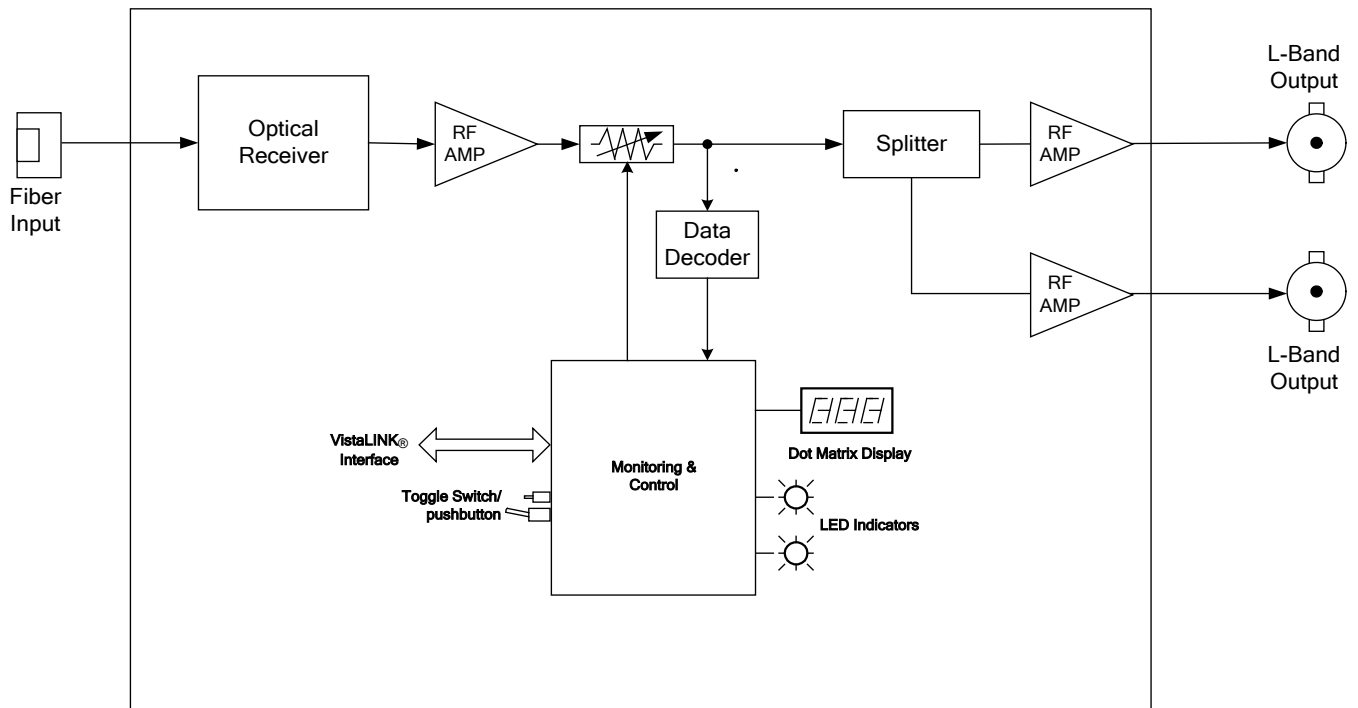

Figure 1-1: 7708LRA/7708LR-H Block Diagram

## 2. INSTALLATION

The 7708LRA/7708LR-H comes with a companion rear plate appropriate for a 1RU, 3RU or standalone enclosure as specified at the time of order. SC/UPC, SC/APC, ST/UPC, FC/UPC or FC/APC optical connectors are available and the type specified at the time of order will be installed. For information on mounting the rear plate and inserting the module into the frame, see the 7700FR manual for detailed instructions.

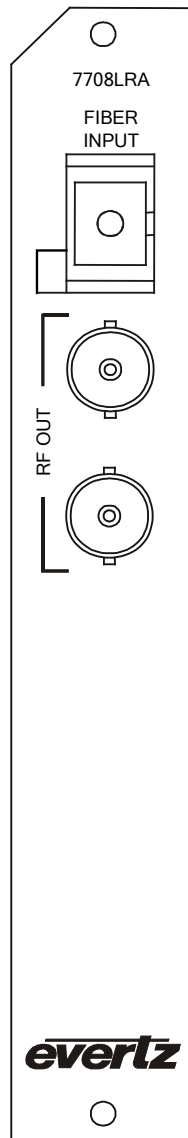

Figure 2-1: 7708LRA/7708LR-H Rear Panel

## 2.1. 7708LRA/7708LR-H CONNECTIONS

**FIBER INPUT:** SC/UPC, SC/APC, ST/UPC, FC/UPC or FC/APC female connector. This connector should be connected with a suitable fiber optic cable to the optical output of an appropriate transmitter at the origin. The standard connector type is UPC. This connector type is compatible with standard PC connectors, but for optimal return loss performance, Evertz recommends the use of UPC fiber terminations throughout the system. The optional APC connectors provide further enhanced return loss performance, and when specified, should also be used throughout the system.

**L-BAND OUT:** Two electrical output connectors for the received L-band signals. The dual connectors provide an extra connector for monitoring or further distribution.



**Unused connectors should be terminated with appropriate loading (50 or 75 Ohm).**

## 2.2. CARE AND HANDLING OF OPTICAL FIBER

### 2.2.1. Handling and Connecting Fibers



**Never touch the end face of an optical fiber. Always keep dust caps on optical fiber connectors when not connected and always remember to properly clean the optical end facet of a connector before making a connection.**

The transmission characteristics of the fiber are dependent on the shape of the optical core and therefore care must be taken to prevent fiber damage due to heavy objects or abrupt fiber bending. Evertz recommends that you maintain a minimum bending radius of 5 cm to avoid fiber-bending loss that will decrease the maximum attainable distance of the fiber cable. Evertz fiber optic modules come with cable lockout devices to prevent the user from damaging the fiber by installing a module into a slot in the frame that does not have a suitable rear plate installed.

### 3. 7708LRA/7708LR-H SPECIFICATIONS

#### 3.1. RF OUTPUT

**Frequency:**

7708LRA: 88MHz – 3000MHz

7708LR-H: 88MHz – 2300MHz

**Connector:**

BNC per IEC 61169-8 Annex A, F type and SMA optional

**I/O Impedance:**

75  $\Omega$  (50  $\Omega$  optional)

**Return Loss:**

>15dB

**Output:**

**AGC Mode:** -10 to -40 dBm (within AGC range)

**Manual or IGC Mode:** -10 to -65dBm (depends on the RF input level and optical loss)

**IGC/AGC hold range:** 30 dB

**OIP3:**

+28 dBm



For detailed link performance specifications, see Specifications section of the accompanying transmitter.

#### 3.2. OPTICAL INPUT

**Number of inputs:**

1

**Connector:**

Female SC/UPC, SC/APC, ST/UPC, FC/UPC, FC/APC

**Operating Wavelength:**

1270nm - 1610nm

**Optical Sensitivity:**

7708LRA: -14 dBm with  $\geq$  35dB CNR\*

7708LR-H: -20 dBm with  $\geq$  35dB CNR\*

**Maximum Input Power:**

7708LRA: +5dBm

7708LR-H: -7dBm

- Tested 36MHz BW source, CNR > 35dB at the transmitter.

#### 3.3. ELECTRICAL

**Voltage:**

+12VDC

**Power:**

5 Watts

**EMI/RFI:**

Complies with FCC regulations for class A devices

Complies with EU EMC directive.

#### 3.4. PHYSICAL

**7800 Series Frame mounting:**

Number of slots: 1



## 4. STATUS INDICATORS AND DISPLAYS

### 4.1. 7708LRA/7708LR-H STATUS INDICATORS

The 7708LRA/7708LR-H has nine LED status indicators on the front card edge to show operational status of the card at a glance. See Figure 5-1 for LED locations.

Two large LEDs on the front of the board indicate the general health of the module:

**LOCAL FAULT:** This red LED indicates poor module health and will be on during the absence of a valid optical input signal or if a local internal power fault exists (i.e.: a blown fuse). Whether or not this LOCAL FAULT indication is reported to the frame may be selected by the FRAME STATUS jumper (see section 5.1).

**MODULE OK:** This green LED indicates good module health. It will be on when a valid optical input signal is present, and the board power is good.

There are 7 small LEDs that indicate the status of the output RF signal, and optical input signal.

**RF HIGH:** This red LED will be on when the output RF signal is higher than the RF high threshold setting.

**RF OK:** This green LED will be on when the output RF signal is within threshold settings.

**RF LOW:** This yellow LED will be on when the output RF signal is lower than the RF low threshold setting.

**OPTICAL INPUT HIGH:** This red LED will be on when the input optical power is higher than the optical power high threshold setting.

**OPTICAL INPUT OK:** This green LED will be on when the input optical power is within threshold settings.

**OPTICAL INPUT LOW:** This yellow LED will be on when the optical power is lower than the optical power low threshold setting.

**GAIN MODE:** This LED is on when AGC or IGC mode is enabled and off when Manual mode is enabled. It will be green when power levels are within the AGC or IGC hold range and a constant RF output level is being maintained. It will be red if power levels are either above or below the power levels required for the AGC/IGC circuit to be able to maintain a constant level.

**SQUELCH MODE:** This LED is on when squelch is enabled. It will be green when squelch is enabled but not active. It will be red when squelch mode is enabled and the output signal is squelched.

## 5. JUMPER POSITIONS

### 5.1. 7708LRA/7708LR-H JUMPERS

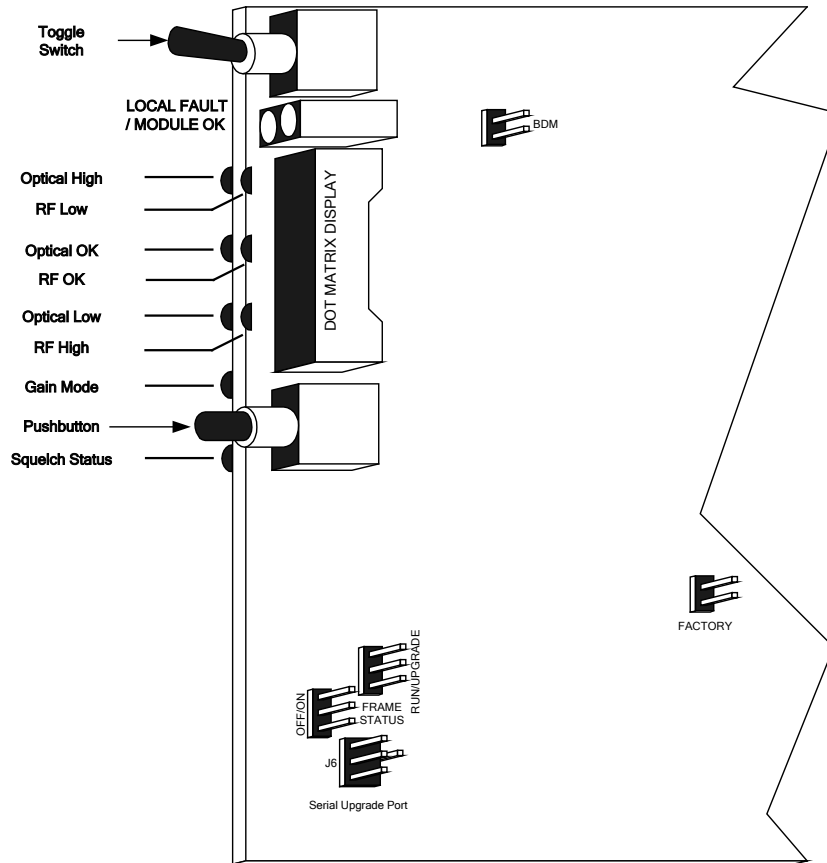

Figure 5-1: Location of 7708LRA/7708LR-H Jumpers and LEDs

### 5.2. SELECTING WHETHER LOCAL FAULTS WILL BE MONITORED BY THE GLOBAL FRAME STATUS

The FRAME STATUS jumper J3 determines whether local faults (as shown by the Local Fault indicator) will be connected to the 7700FR frame's global status bus.

**FRAME STATUS:** To monitor faults on this module with the frame status indicators (on the Power Supply FRAME STATUS LEDs and on the Frame's Fault Tally output) install this jumper in the ON position (default).

When this jumper is installed in the Off position local faults on this module will not be monitored.

### 5.3. CONFIGURING THE MODULE FOR FIRMWARE UPGRADES

**UPGRADE:** The UPGRADE jumper J5 is used when firmware upgrades are being done to the module. For normal operation it should be installed in the *RUN* position. See the *Upgrading Firmware* section of this manual for more information.

To upgrade the firmware:

1. Pull the module out of the frame.
2. Move the UPGRADE jumper into the *UPGRADE* position.
3. Install the Upgrade cable provided (located in the vinyl pouch in the front of this manual) onto the SERIAL header at the card edge.
4. Re-install the module into the frame.
5. Run the upgrade as described in the *Upgrading Firmware* section of this manual.
6. When the upgrade is completed, remove the module from the frame, move the UPGRADE jumper into the *RUN* position, remove the upgrade cable and re-install the module.

The module is now ready for normal operation.

Note that if installed in a frame with a 7700FC frame controller, the 7708LRA/7708LR-H may also be conveniently upgraded through Evertz VistaLINK PRO, without service interruption. Consult VistaLINK<sup>®</sup> PRO documentation for details on this feature.

### 5.4. FACTORY AND BDM JUMPERS

When shipped from the Evertz facility, the FACTORY and BDM jumpers will not be installed. These jumpers **should not** be installed for any reason. If jumpers are on these positions they should be removed.

## 6. DOT-MATRIX DISPLAY

Signal and status monitoring and control of the card's parameters are provided via the four-digit alphanumeric display located on the card edge. The card-edge toggle-switch (see Figure 5-1) is used to navigate through the display menus and the push button is used to select options. Figure 6-1 provides a quick reference to the display menu structure.

`CTRL` menu items have user-adjustable configuration values associated with them. `STAT` menu items display operating conditions or configuration values, but do not allow adjustment.

If a specific menu selection has a configuration value associated with it, then this may be changed using the toggle switch. Pressing the pushbutton will apply the displayed value and return you to the previous menu level.



**Note: The most recent user selection will be maintained in non-volatile memory in the event of power loss to the module.**

Pushbutton →					
Top Level	Menu Level 1	Menu Level 2	Menu Level 3	Menu Level 4	Menu Level 5
Indications > LASR_ERR (Laser Error) OK (Laser OK)	CTRL (Control)	RX (Receiver)	OPTH (Optical Alarm Threshold)	Selections > LWR (Lower) UPPR (Upper)	Selections > -1 to -40 dBm Selections > 7708LRA: +5 to -3 dBm 7708LR-H: -7 to -13 dBm
			RFTH (RF Thresholds)	Selections > LWR (Lower alarm threshold) UPPR (Upper alarm threshold) SQL (Squelch threshold)	Selections > -30 to -55 dBm 0 to -29 dBm Selections > -40 to -65 dBm
MODE (Gain Mode)			Selections > AGC (AGC mode) IGC (IGC mode) MAN (Manual gain)	Selections > -10 to 31.5 dBm (LRA) -10 to 28.5 dBm (LR-H) Selections > -10 to -40 dBm Selections > EN (Squelch enabled) DIS (Squelch disabled)	
GAIN (Manual gain - when MODE set to MAN or IGC)			Selections >		
OURL (AGC target level - when MODE set to AGC)			Selections >		
SQL (Squelch)			Selections >		
TX (Transmitter)			RFTH (RF Alarm Threshold)	Selections > LWR (Lower) UPPR (Upper)	Selections > -30 to -65 dBm 0 to -29 dBm
			TPTH (Temperature Alarm Threshold)	Selections > LWR (Lower) UPPR (Upper)	Selections > -40 to +125 deg. C -40 to +125 deg. C
			PWTH (Input Power Alarm Threshold)	Selections > LWR (Lower) UPPR (Upper)	Selections > 11 to 15 Volts DC 16 to 23 Volts DC
			LCTH (LNB Current Alarm Threshold)	Selections > LWR (Lower) UPPR (Upper)	Selections > 0 to 500 mA 0 to 500 mA
	DISP (Display Orientation)	Selections > HORZ (Horizontal) VERT (Vertical)			
	FRST (Restore factory default settings)	Selections > YES (Perform reset) NO (Do not perform reset)			
STAT (Status)	RX (Receiver)	OPWR (Optical input power)	Selections > +7 to -40 dBm or LOW		
		RPWR (RF output power)	Indications > 0 to -60 dBm		
		SQL (Squelch status)	Indications > DIS (Disabled) ACT (Enabled and active) NACT (Enabled and not active)		
	TX (Transmitter)	TONE (Return data tone)	Selections > PRES (Return data present) LOSS (Return data not present)		
		INPL (Input RF Level)	Indications > +10 to -65 dBm		
		MODE (Gain Mode)	Indications > AGC (AGC mode) MAN (Manual gain)		
		GAIN (Gain level applied)	Indications > 0 to +31 dB		
		AGC (AGC Status)	Indications > OFF (Manual gain mode) OK (Input within AGC range) HIGH (Input above AGC range) LOW (Input below AGC range)		
		RFDR (RF Drive)	Indications > HIGH (Overdriving laser) OK (Normal drive) LOW (Underdriving laser)		
		OPWR (Optical output power)	Indications > +10 to -10 dBm		
		LASR (Laser Status)	Indications > OK (OK) DGRD (Degraded)		
		PSU (Power Supply)	Selections > VOLT (Voltage) STAT (Status)	Indications > 10 to 23 Volts Indications > OK (OK) FAIL (Redundant PSU Failed)	
		TEMP (Internal temperature)	Indications > -40 to +125 deg. C		
		LNBM (LNB Power Mode)	Indications > OFF (Off) BYP (DC Pass mode) BYPT (DC Pass + 22 kHz) 13V (13 VDC) 13VT (13 VDC + 22 kHz)		
		LNBV (Measured LNB Voltage)	Indications > 0 to 23 VDC		
		LNBC (Measured LNB Current)	Indications > 0 to 550 mA		
		VER (Firmware version)	Indications > Firmware version		
		TYPE (Transmitter model)	Indications > Transmitter model		
		VER (Firmware version)	Indications > Firmware version		

Toggle Switch  
↑  
↓

Figure 6-1: Card Edge Menu Structure

## 6.1. 7708LRA/7708LR-H CONTROLLED PARAMETERS

To change the 7708LRA/7708LR-H parameters, select the **CTRL** menu item in menu level 1. Use the toggle switch to select the **RX** menu item and press the pushbutton. The toggle switch may then be used to select the parameter to change as described below:

### 6.1.1. Adjusting the Optical Power Alarm Thresholds

The 7708LRA/7708LR-H measures and can display the input optical power over a range of +7dBm to –40dBm in increments of 1dBm. Alarm points may be set for high input optical power, and low input optical power. These alarms will appear locally on the card edge LEDs (see Section 3) and remotely via SNMP traps. To adjust the optical power alarm thresholds, select the **CTRL** menu item in the first menu level, then use the toggle switch to display the **RX** option and press the pushbutton to select it. Use the toggle switch to display the **OPTH** option and press the pushbutton to select it. Use the toggle switch to then select from the **UPPR** and **LWR** thresholds. Choices are as follows:

CTRL	-1 to -40 dBm	7708LRA: Lower optical power alarm threshold (default -14 dBm).
RX		
OPTH	-4 to -40 dBm	7708LR-H: Lower optical power alarm threshold (default -20 dBm).
LWR		
-1 to -40 dBm -4 to -40 dBm		
CTRL	+5 to -3 dBm	7708LRA: Upper optical power alarm threshold (default +3 dBm).
RX		
OPTH	-7 to -13 dBm	7708LR-H: Upper optical power alarm threshold (default -7 dBm).
UPPR		
+5 to -3 dBm -7 to -13 dBm		

### 6.1.2. Adjusting the RF Output Power Alarm and Squelch Thresholds

The 7708LRA/7708LR-H measures and can display the output RF power over a range of 0dBm to –60dBm in increments of 1dBm. Alarms may be set for high and low output RF power that will appear locally on the card edge LEDs (see Section 3) and remotely via SNMP traps. To set the alarm threshold points, select the **CTRL** menu item in the first menu level, then use the toggle switch to display the **RX** option and press the pushbutton to select it. Use the toggle switch to display the **RFTH** option and press the pushbutton to select it. Use the toggle switch to then select from the **UPPR** and **LWR** thresholds. Choices are as follows:

CTRL	-30 to -55 dBm	Lower RF power alarm threshold (default -55 dBm).
RX		
RFTH		
LWR		
-30 to -55 dBm		

CTRL		0 to -29 dBm	Upper optical power alarm threshold (default -5 dBm).
RX			
RFTH			
UPPR			
0 to -29 dBm			

Additionally, the RF Squelch threshold may be set from this menu via the SQL selection. The squelch level is based on the RF input power to the transmitter, and therefore this threshold feature will only function when a compatible transmitter that sends monitoring information down the fiber is connected, such as the 2407LT.

CTRL		-40 to -65 dBm	RF power entering at the transmitter at which point the output should be squelched (default -60 dBm).
RX			
RFTH			
SQL			
-40 to -65 dBm			

### 6.1.3. Selecting the Output Gain Mode

The 7708LRA/7708LR-H has several gain modes available:

**Manual** gain mode allows the user to select a fixed gain level for the RF signal.

**AGC** (automatic gain control) will maintain a constant output level even if the input RF level changes, as long as this input level does not go outside of the AGC hold range. The AGC target level is user adjustable (see Section 6.1.5).

**IGC** mode compensates for optical loss and outputs an RF signal level proportional to what is coming into the transmitter, within the signal level capabilities of the receiver. The IGC mode is based on the RF input power to the transmitter, and therefore this feature will only function when a transmitter featuring SmartMON™ is used. With no gain applied, the output signal from the 7708LRA/7708LR-H will be at the same level as the input to the transmitter. Additional gain may be applied to this signal level (see next section) as an offset. **Note that this mode will not be available unless an appropriate SmartMON™ capable transmitter that sends monitoring data down the fiber is connected.**

To select the gain mode, select the CTRL menu item in the first menu level, then use the toggle switch to display the RX option and press the pushbutton to select it. Use the toggle switch to display the MODE option and press the pushbutton to select it.

CTRL		AGC	AGC mode (default).
RX			
MODE			
AGC			
IGC			
MAN		IGC	IGC mode.

### 6.1.4. Adjusting the RF Output Gain

The 7708LRA/7708LR-H can apply gain to adjust the level of the output signal in 0.5 dB increments. Gain may be applied when the card is set for manual or IGC modes (see previous section). To set the gain, select the `CTRL` menu item in the first menu level, then use the toggle switch to display the `RX` option and press the pushbutton to select it. Use the toggle switch to display the `GAIN` option and press the pushbutton to select it.

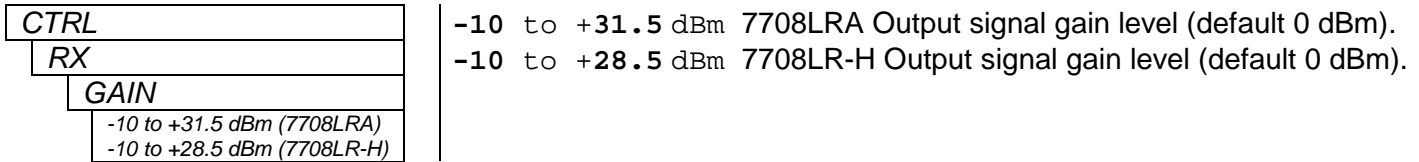

**Note that this menu item is not applicable and therefore not visible when in AGC mode.**

### 6.1.5. Adjusting the AGC Target Level

The target output level to be maintained by the 7708LRA/7708LR-H when in AGC mode is user adjustable. To set the AGC target level, select the `CTRL` menu item in the first menu level, then use the toggle switch to display the `RX` option and press the pushbutton to select it. Use the toggle switch to display the `OUTL` option and press the pushbutton to select it.

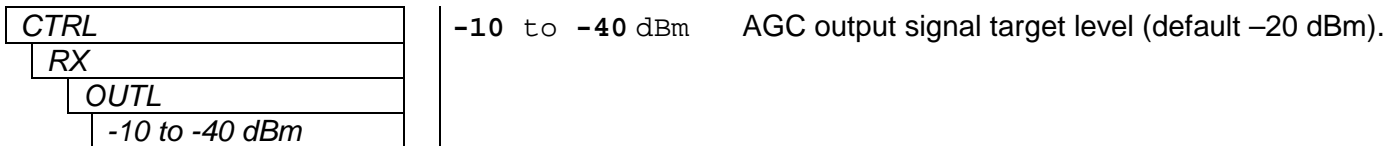

**Note that this menu item is only applicable and visible when the card is set to operate in AGC mode.**

### 6.1.6. Enabling/Disabling Squelch Mode

Squelch mode will turn off the RF output if it drops below a certain input power level as reported by the transmitter (see section 6.1.2) or if the input optical power drops below -40 dBm. To enable or disable squelch mode, select the `CTRL` menu item in the first menu level, then use the toggle switch to display the `RX` option and press the pushbutton to select it. Use the toggle switch to display the `SQL` option and press the pushbutton to select it.



CTRL	EN	Enable squelch mode.
RX	DIS	Disable squelch mode (default).
SQL		
EN		
DIS		

### 6.1.7. Setting the Card Edge Display Orientation

The **DISP** display option allows the user to set a horizontal or vertical orientation for the card edge display messages. To set the display orientation, select the **CTRL** menu item in menu level 1, then use the toggle switch to display the **DISP** menu selection and use the pushbutton to select it. Use the toggle switch to change between **HOR** and **VERT**. Press the push button to make your selection.

CTRL	HORZ	Horizontal display used when the module is housed in the 1 rack unit 7701FR frame or the stand-alone enclosure.
DISP	VERT	Vertical display used when the module is housed in the 3-rack unit 7700FR frame.
HORZ		
VERT		

### 6.1.8. Resetting Factory Defaults

The **FRST** menu option will return the 7708LRA/7708LR-H to factory defaults. To return all settings to factory defaults, select the **CTRL** menu item in menu level 1, then use the toggle switch to display the **FRST** menu selection and use the pushbutton to select it.

CTRL	YES	Perform factory reset.
FRST	NO	Do not perform factory reset.
YES		
NO		

## 6.2. TRANSMITTER CONTROLLABLE PARAMETERS

The 7708LRA/7708LR-H can decode and display monitoring data sent across the fiber by compatible Evertz transmitters featuring SmartMON™. Several of these monitored parameters are suitable for alarming via SNMP/VistaLINK. The thresholds for these alarms may be adjusted via the card edge or through SNMP. **Note that these menu items will not be available unless an appropriate SmartMON™ equipped transmitter that sends monitoring data down the fiber is connected.**



**Note: Not all compatible transmitter models have the same controllable parameters - only those applicable to the specific transmitter model will be available. See the following table for parameters related to the connected transmitter.**

Parameter	2407LTA	2408LT
<b>RF Power Alarm Thresholds</b>	X	X
<b>Temperature Alarm Thresholds</b>	X	X
<b>Input DC Alarm Thresholds</b>	X	X
<b>LNB Current Alarm Thresholds</b>		X

### 6.2.1. Adjusting the RF Input Power Alarm Thresholds

SNMP alarms may be set for high and low input RF power to the transmitter. To set the alarm threshold points, select the **CTRL** menu item in the first menu level, then use the toggle switch to display the **TX** option and press the pushbutton to select it. Use the toggle switch to display the **RFTH** option and press the pushbutton to select it. Use the toggle switch to then select from the **UPPR** and **LWR** thresholds. Choices are as follows:

<div style="border: 1px solid black; padding: 2px; margin-bottom: 2px;">CTRL</div> <div style="border: 1px solid black; padding: 2px; margin-bottom: 2px; margin-left: 20px;">TX</div> <div style="border: 1px solid black; padding: 2px; margin-bottom: 2px; margin-left: 40px;">RFTH</div> <div style="border: 1px solid black; padding: 2px; margin-bottom: 2px; margin-left: 60px;">LWR</div> <div style="border: 1px solid black; padding: 2px; margin-left: 80px;">-30 to -65 dBm</div>		-30 to -65 dBm		Lower RF power alarm threshold (default -65 dBm).
<div style="border: 1px solid black; padding: 2px; margin-bottom: 2px;">CTRL</div> <div style="border: 1px solid black; padding: 2px; margin-bottom: 2px; margin-left: 20px;">TX</div> <div style="border: 1px solid black; padding: 2px; margin-bottom: 2px; margin-left: 40px;">RFTH</div> <div style="border: 1px solid black; padding: 2px; margin-bottom: 2px; margin-left: 60px;">UPPR</div> <div style="border: 1px solid black; padding: 2px; margin-left: 80px;">0 to -29 dBm</div>		0 to -29 dBm		Upper optical power alarm threshold (default -5 dBm).

### 6.2.2. Adjusting the Internal Transmitter Temperature Alarm Thresholds

SNMP alarms may be set for high and low internal temperature readings at the transmitter. To set the alarm threshold points, select the **CTRL** menu item in the first menu level, then use the toggle switch to display the **TX** option and press the pushbutton to select it. Use the toggle switch to display the **TPTH** option and press the pushbutton to select it. Use the toggle switch to then select from the **UPPR** and **LWR** thresholds. Choices are as follows:

<div style="border: 1px solid black; padding: 2px; margin-bottom: 2px;">CTRL</div> <div style="border: 1px solid black; padding: 2px; margin-bottom: 2px; margin-left: 20px;">TX</div> <div style="border: 1px solid black; padding: 2px; margin-bottom: 2px; margin-left: 40px;">TPTH</div> <div style="border: 1px solid black; padding: 2px; margin-bottom: 2px; margin-left: 60px;">LWR</div> <div style="border: 1px solid black; padding: 2px; margin-left: 80px;">-40 to +125 deg C.</div>		-40 to +125 deg C.		Lower temperature alarm threshold (default 0 deg C.)
<div style="border: 1px solid black; padding: 2px; margin-bottom: 2px;">CTRL</div> <div style="border: 1px solid black; padding: 2px; margin-bottom: 2px; margin-left: 20px;">TX</div> <div style="border: 1px solid black; padding: 2px; margin-bottom: 2px; margin-left: 40px;">TPTH</div> <div style="border: 1px solid black; padding: 2px; margin-bottom: 2px; margin-left: 60px;">UPPR</div> <div style="border: 1px solid black; padding: 2px; margin-left: 80px;">-40 to +125 deg C.</div>		-40 to +125 deg C.		Upper temperature alarm threshold (default 85 deg C.)

### 6.2.3. Adjusting the Input Voltage Alarm Thresholds

SNMP alarms may be set for high and low DC input Voltage at the transmitter. To set the alarm threshold points, select the **CTRL** menu item in the first menu level, then use the toggle switch to display the **TX** option and press the pushbutton to select it. Use the toggle switch to display the **PWTH** option and press the pushbutton to select it. Use the toggle switch to then select from the **UPPR** and **LWR** thresholds.

<table border="1" style="width: 100%; border-collapse: collapse;"> <tr><td style="padding: 2px;">CTRL</td></tr> <tr><td style="padding: 2px;">TX</td></tr> <tr><td style="padding: 2px;">PWTH</td></tr> <tr><td style="padding: 2px;">LWR</td></tr> <tr><td style="padding: 2px;">11 to 15 VDC</td></tr> </table>	CTRL	TX	PWTH	LWR	11 to 15 VDC	11 to 15 VDC	Lower input voltage alarm threshold (default 11 VDC.)
CTRL							
TX							
PWTH							
LWR							
11 to 15 VDC							
<table border="1" style="width: 100%; border-collapse: collapse;"> <tr><td style="padding: 2px;">CTRL</td></tr> <tr><td style="padding: 2px;">TX</td></tr> <tr><td style="padding: 2px;">PWTH</td></tr> <tr><td style="padding: 2px;">UPPR</td></tr> <tr><td style="padding: 2px;">16 to 23 VDC</td></tr> </table>	CTRL	TX	PWTH	UPPR	16 to 23 VDC	16 to 23 VDC	Upper input voltage alarm threshold (default 20 VDC.)
CTRL							
TX							
PWTH							
UPPR							
16 to 23 VDC							

### 6.2.4. Adjusting the LNB Current Alarm Thresholds

SNMP alarms may be set for high and low LNB current at the transmitter, providing a convenient means of remotely monitoring LNB condition. To set the alarm threshold points, select the CTRL menu item in the first menu level, then use the toggle switch to display the TX option and press the pushbutton to select it. Use the toggle switch to display the LCTH option and press the pushbutton to select it. Use the toggle switch to then select from the UPPR and LWR thresholds.

<table border="1" style="width: 100%; border-collapse: collapse;"> <tr><td style="padding: 2px;">CTRL</td></tr> <tr><td style="padding: 2px;">TX</td></tr> <tr><td style="padding: 2px;">LCTH</td></tr> <tr><td style="padding: 2px;">LWR</td></tr> <tr><td style="padding: 2px;">0 to 500 mA</td></tr> </table>	CTRL	TX	LCTH	LWR	0 to 500 mA	0 to 500 mA	Lower LNB current alarm threshold (default 0 mA.)
CTRL							
TX							
LCTH							
LWR							
0 to 500 mA							
<table border="1" style="width: 100%; border-collapse: collapse;"> <tr><td style="padding: 2px;">CTRL</td></tr> <tr><td style="padding: 2px;">TX</td></tr> <tr><td style="padding: 2px;">LCTH</td></tr> <tr><td style="padding: 2px;">UPPR</td></tr> <tr><td style="padding: 2px;">0 to 500 mA</td></tr> </table>	CTRL	TX	LCTH	UPPR	0 to 500 mA	0 to 500 mA	Upper input voltage alarm threshold (default 500 mA.)
CTRL							
TX							
LCTH							
UPPR							
0 to 500 mA							

## 6.3. 7708LRA/7708LR-H MONITORED CONDITIONS AND PARAMETERS

To view the 7708LRA/7708LR-H monitored parameters, select the STAT menu item in menu level 1. Use the toggle switch to select the RX menu item and press the pushbutton. The toggle switch may then be used to select the parameter to view as described below:

### 6.3.1. Displaying the Input Optical Power

The 7708LRA/7708LR-H measures and can display the input optical power over a range of +7dBm to –40dBm in increments of 1dBm. To display the input optical power, select the STAT menu item in the first menu level, then use the toggle switch to display the RX option and press the pushbutton to select it. Use the toggle switch to display the OPWR option and press the pushbutton to select it.

STAT		+7 to -40	Optical input power within this range. Input optical power low (< -40 dBm).
RX		LOW	
OPWR			
+7 to -40 dBm LOW			

### 6.3.2. Displaying the Output RF Power

The 7708LRA/7708LR-H measures and can display the output RF power over a range of 0dBm to – 60dBm in increments of 1dBm. To display the output RF power, select the *STAT* menu item in the first menu level, then use the toggle switch to display the *RX* option and press the pushbutton to select it. Use the toggle switch to display the *OPWR* option and press the pushbutton to select it.

STAT		0 to -60 dBm	Output RF power within this range.
RX			
RPWR			
0 to -60 dBm			

### 6.3.3. Displaying the Squelch Status

To display the squelch mode setting and status, select the *STAT* menu item in the first menu level, then use the toggle switch to display the *RX* option and press the pushbutton to select it. Use the toggle switch to display the *SQL* option and press the pushbutton to select it.

STAT		DIS	Squelch mode disabled. Squelch mode enabled and active (output signal squelched). Squelch mode enables and not active.
RX		ACT	
SQL		NACT	
DIS ACT NACT			

## 6.4. TRANSMITTER MONITORED PARAMETERS

The 7708LRA/7708LR-H can decode and display monitoring data sent across the fiber by compatible Evertz transmitters featuring SmartMON™. To view the monitored parameters of the connected transmitter, select the *STAT* menu item in menu level 1. Use the toggle switch to select the *TX* menu item and press the pushbutton. The toggle switch may then be used to select the parameter to view as described below. Note that these parameters will not be available for viewing unless the connected transmitter has the feature to send monitoring data down the fiber.



**Note: Not all compatible transmitter models send the same parameters – only those applicable to the specific transmitter model will be displayed. See the following table for parameters related to the connected transmitter.**

Parameter	2407LTA	2408LT
Input RF Level	X	X
Gain Mode	X	X
Applied Gain	X	X
AGC Status	X	X
RF Drive	X	X
Optical Output Power	X	X
Laser Status	X	X
Power Supply Status	X	X
Internal Temperature	X	X
LNB Power Mode	X	X
LNB Voltage	X	X
LNB Current		X
Firmware Version	X	X
Transmitter Model	X	X

### 6.4.1. Displaying the Presence of the Data Signal

The 7708LRA/7708LR-H detects and can display the presence or loss of the SmartMON™ data signal from a companion transmitter. To display the status of this data signal, select the *STAT* menu item in the first menu level, then use the toggle switch to display the *TX* option and press the pushbutton to select it. Use the toggle switch to display the *TONE* option and press the pushbutton to select it.

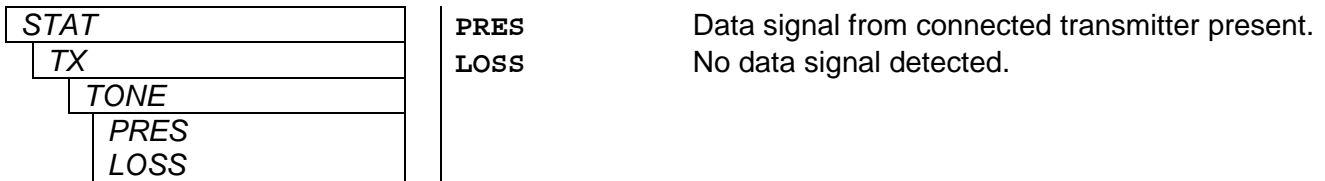

**Note:** The following menu items will not be displayed unless the data signal from a SmartMON™ equipped transmitter is detected.

### 6.4.2. Displaying the Input RF Power to the Connected Transmitter

To display the input RF power to the transmitter, select the *STAT* menu item in the first menu level, then use the toggle switch to display the *TX* option and press the pushbutton to select it. Use the toggle switch to display the *INPL* option and press the pushbutton to select it.

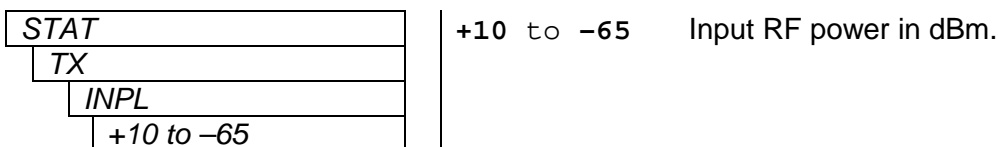

### 6.4.3. Displaying the Gain Mode of the Connected Transmitter

To display the gain mode of the connected transmitter, select the *STAT* menu item in the first menu level, then use the toggle switch to display the *TX* option and press the pushbutton to select it. Use the toggle switch to display the *MODE* option and press the pushbutton to select it.

<i>STAT</i>	<b>AGC</b>	Gain mode is AGC (automatic gain control).
<i>TX</i>	<b>MAN</b>	Gain mode is manual.
<i>MODE</i>		
<i>AGC</i>		
<i>MAN</i>		

### 6.4.4. Displaying the Gain Level of the Connected Transmitter

To display the gain level of the connected transmitter, select the *STAT* menu item in the first menu level, then use the toggle switch to display the *TX* option and press the pushbutton to select it. Use the toggle switch to display the *GAIN* option and press the pushbutton to select it.

<i>STAT</i>	<b>0 to 31 dB</b>	Gain level set either manually, or automatically applied by the transmitter if in AGC mode.
<i>TX</i>		
<i>GAIN</i>		
<i>0 to 31 dB</i>		

### 6.4.5. Displaying the AGC Status of the Connected Transmitter

To display the AGC Status of the connected transmitter, select the *STAT* menu item in the first menu level, then use the toggle switch to display the *TX* option and press the pushbutton to select it. Use the toggle switch to display the *AGC* option and press the pushbutton to select it.

<i>STAT</i>	<b>OFF</b>	AGC mode is off (transmitter is set for manual gain mode).
<i>TX</i>	<b>OK</b>	AGC mode is selected, and the input RF power to the transmitter is within the AGC hold range.
<i>AGC</i>	<b>HIGH</b>	AGC mode is selected, and the input RF power to the transmitter is above the AGC hold range.
<i>OFF</i>	<b>LOW</b>	AGC mode is selected, and the input RF power to the transmitter is below the AGC hold range.
<i>OK</i>		
<i>HIGH</i>		
<i>LOW</i>		

### 6.4.6. Displaying the RF Drive Status of the Connected Transmitter

To display the RF Drive status of the connected transmitter, select the *STAT* menu item in the first menu level, then use the toggle switch to display the *TX* option and press the pushbutton to select it. Use the toggle switch to display the *RFDR* option and press the pushbutton to select it.

STAT	HIGH	Laser is being over driven – this may appear as IMD products on the received signal.		
TX				
RFDR			OK LOW	Laser is being driven at normal levels. Laser is being under-driven – this may appear as low S/N ratio on the received signal.
HIGH OK LOW				

#### 6.4.7. Displaying the Output Optical Power of the Connected Transmitter

To display the output optical power of the connected transmitter, select the *STAT* menu item in the first menu level, then use the toggle switch to display the *TX* option and press the pushbutton to select it. Use the toggle switch to display the *OPWR* option and press the pushbutton to select it.

STAT	+10 to -10 dBm	Laser output power.
TX		
OPWR		
+10 to -10 dBm		

#### 6.4.8. Displaying the Laser Status of the Connected Transmitter

To display the laser status of the connected transmitter, select the *STAT* menu item in the first menu level, then use the toggle switch to display the *TX* option and press the pushbutton to select it. Use the toggle switch to display the *LASR* option and press the pushbutton to select it.

STAT	OK DGRD	Laser is operating normally. Laser operation is degraded, or laser has reached approximately 80% of its useful lifespan.
TX		
LASR		
DGRD OK		

#### 6.4.9. Displaying Status of the Power Supply Connected to the Transmitter

To display the status of the power supply connected to the transmitter, select the *STAT* menu item in the first menu level, then use the toggle switch to display the *TX* option and press the pushbutton to select it. Use the toggle switch to display the *PSU* option and press the pushbutton to select it. Then select from *VOLT* to show the DC input voltage to the transmitter as provided by the power supply, or select *STAT* to check the status of the internal power supplies (applicable only on Evertz power supplies capable of sending monitoring information to the transmitter).

STAT	18 to 23 VDC	DC Voltage level entering the transmitter
TX		
PSU		
VOLT		
18 to 23 VDC		

STAT	OK	Connected power supply internal modules are both OK.
TX	FAIL	One internal module in the connected power supply has failed and redundancy has been lost.
PSU		
STAT		
OK		
FAIL		

#### 6.4.10. Displaying the Internal Temperature of the Connected Transmitter

To display the internal temperature of the connected transmitter, select the *STAT* menu item in the first menu level, then use the toggle switch to display the *TX* option and press the pushbutton to select it. Use the toggle switch to display the *TEMP* option and press the pushbutton to select it.

STAT	-40 to +125 deg C.	Internal temperature of the connected transmitter.
TX		
TEMP		
-40 to +125 deg C.		

#### 6.4.11. Displaying the LNB Mode of the Connected Transmitter

To display the LNB Mode of the connected transmitter, select the *STAT* menu item in the first menu level, then use the toggle switch to display the *TX* option and press the pushbutton to select it. Use the toggle switch to display the *LNBM* option and press the pushbutton to select it.

STAT	OFF	LNB supply is turned off.
TX	13V	LNB supply is set for 13VDC.
LNBM	13VT	LNB supply is set for 13VDC + 22kHz.
OFF	17V	LNB supply is set for 17VDC.
13V	17VT	LNB supply is set for 17VDC + 22kHz.
13VT	BYP	LNB supply is set for DC Pass mode and LNB power is supplied directly by the connected power supply.
17V		
17VT	BYPT	LNB supply is set for DC Pass +22kHz mode and LNB power is supplied directly by the connected power supply.
BYP		
BYPT		

#### 6.4.12. Displaying the LNB Voltage of the Connected Transmitter

To display the LNB Voltage of the connected transmitter, select the *STAT* menu item in the first menu level, then use the toggle switch to display the *TX* option and press the pushbutton to select it. Use the toggle switch to display the *LNBV* option and press the pushbutton to select it.

STAT	0 to 23 VDC	Voltage supplied to the LNB as specified by the LNB mode setting, or as provided by the connected power supply if in DC PASS mode.
TX		
LNBV		
0 to 23 VDC		



### 6.4.13. Displaying the LNB Current

To display the LNB Current, select the `STAT` menu item in the first menu level, then use the toggle switch to display the `TX` option and press the pushbutton to select it. Use the toggle switch to display the `LNBC` option and press the pushbutton to select it.

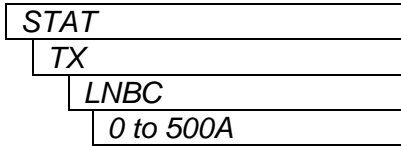

Indicates the LNB current. Visible for -LNB versions only.

0 to 500 A RF current range.

### 6.4.14. Displaying the Firmware Version of the Connected Transmitter

To display the firmware version of the connected transmitter, select the `STAT` menu item in the first menu level, then use the toggle switch to display the `TX` option and press the pushbutton to select it. Use the toggle switch to display the `VER` option and press the pushbutton to select it. The firmware version will scroll across the display.

For example: `VER 1.0 BUILD 006`

### 6.4.15. Displaying the Model of the Connected Transmitter

To display the model of the connected transmitter, select the `STAT` menu item in the first menu level, then use the toggle switch to display the `TX` option and press the pushbutton to select it. Use the toggle switch to display the `TYPE` option and press the pushbutton to select it. The model will scroll across the display.

For example: `2408LT`

---

## **7. VISTALINK<sup>®</sup> REMOTE MONITORING/CONTROL - 7703 VERSIONS**

### **7.1. WHAT IS VISTALINK<sup>®</sup>?**

VistaLINK<sup>®</sup> is Evertz's remote monitoring and configuration platform which operates over an Ethernet network using Simple Network Management Protocol (SNMP). SNMP is a standard computer network protocol that enables different devices sharing the same network to communicate with each other. VistaLINK<sup>®</sup> provides centralized alarm management, which monitors, reports, and logs all incoming alarm events and dispatches alerts to all the VLPro Clients connected to the server. Card configuration through VistaLINK<sup>®</sup> PRO can be performed on an individual or multi-card basis using simple copy and paste routines, which reduces the time to configure each module separately. Finally, VistaLINK<sup>®</sup> enables the user to configure devices in the network from a central station and receive feedback that the configuration has been carried out.

There are 3 components of SNMP:

1. An SNMP manager, also known as a Network Management System (NMS), is a computer running special software that communicates with the devices in the network. Evertz VistaLINK<sup>®</sup> Pro Manager graphical user interface (GUI), third party or custom manager software may be used to monitor and control Evertz VistaLINK<sup>®</sup> enabled fiber optic products.
2. Managed devices, each with a unique address (OID), communicate with the NMS through an SNMP Agent. Evertz VistaLINK<sup>®</sup> enabled 7700 series modules reside in the 3RU 7700FR-C MultiFrame and communicate with the manager via the 7700FC VistaLINK<sup>®</sup> frame controller module, which serves as the Agent.
3. A virtual database, known as the Management Information Base (MIB), lists all the variables being monitored, which both the Manager and Agent understand. Please contact Evertz for further information about obtaining a copy of the MIB for interfacing to a third party Manager/NMS.

For more information on connecting and configuring the VistaLINK<sup>®</sup> network, see the 7700FC Frame Controller chapter.

**7.1.1. 7708LRA/7708LR-H VistaLINK® Monitored Parameters**

7708LRA/7708LR-H Parameter	Description
Optical Power	Receiver Input Optical Power
RF Output Power	Receiver RF output power
Gain	Receiver gain setting
Squelch	Receiver squelch status
Firmware Version	Receiver firmware version
RF Input Power	Transmitter RF input power
Gain Mode	Transmitter gain mode
Gain	Transmitter applied gain
AGC State	Transmitter AGC state
RF Drive	Transmitter RF drive status
Optical output power	Transmitter optical output power
LASER status	Transmitter laser status
DC Input power	Transmitter DC input power
PSU redundant supply status	Transmitter connected DC power supply status
LNB control setting	Transmitter LNB mode setting
LNB Voltage	Transmitter LNB voltage
LNB Current	Transmitter current supplied to connected LNB
Temperature	Transmitter internal temperature
Firmware Version	Transmitter firmware version
Transmitter Model	Transmitter model

**Table 7-1: VistaLINK® Monitored Parameters**

**7.1.2. 7708LRA/7708LR-H VistaLINK® Controlled Parameters**

7708LRA/7708LR-H Parameter	Description
Lower Optical Power Threshold	Receiver low optical power alarm threshold
Upper Optical Power Threshold	Receiver high optical power alarm threshold
Lower RF Output Power Threshold	Receiver low RF power alarm threshold
Upper RF Output Power Threshold	Receiver high RF power alarm threshold
Gain	Receiver Output signal gain
AGC RF Output Level	Receiver AGC target level
Gain mode	Receiver Gain mode (manual, AGC, IGC)
Squelch	Receiver Squelch mode enable/disable
Squelch Threshold	Receiver Squelch threshold setting
Lower RF Input power Threshold	Transmitter low RF power alarm threshold
Upper RF Input power Threshold	Transmitter high RF power alarm threshold
Lower Temperature Threshold	Transmitter low temperature power alarm threshold
Upper Temperature Threshold	Transmitter high temperature power alarm threshold
Lower DC supply input voltage Threshold	Transmitter low DC input voltage alarm threshold
Upper DC supply input voltage Threshold	Transmitter high DC input voltage alarm threshold
Lower LNB Current Threshold	Transmitter low LNB current alarm threshold
Upper LNB Current Threshold	Transmitter high LNB current alarm threshold

**Table 7-2: VistaLINK® Controlled Parameters**

7.1.3. 7708LRA/7708LR-H VistaLINK® Traps

7708LRA/7708LR-H Traps	Description
RF Output Power High	Receiver RF output high
RF Output Power Low	Receiver RF output low
Optical Input Power High	Receiver optical input high
Optical Input Power Low	Receiver optical input low
AGC out of Range	Receiver out of AGC range
Squelch Active	Receiver output signal squelched
RF Input Power High	Transmitter RF input high
RF Input Power Low	Transmitter RF input low
Temperatue High	Transmitter temperature high
Temperatue Low	Transmitter temperature low
DC Supply High	Transmitter DC input voltage high
DC Supply Low	Transmitter DC input voltage low
RF Drive High	Transmitter RF Drive high
RF Drive Low	Transmitter RF Drive low
LNB Current High	Transmitter LNB current high
LNB Current Low	Transmitter LNB current low
LNB Short	LNB current overload or short circuit

Table 7-3: VistaLINK® Traps