

## TABLE OF CONTENTS

<b>1. OVERVIEW .....</b>	<b>1</b>
<b>1.1. HOW TO USE THIS MANUAL .....</b>	<b>2</b>
<b>2. INSTALLATION .....</b>	<b>5</b>
<b>2.1. REAR PANEL .....</b>	<b>5</b>
2.1.1. Program Video Inputs (3G/HD/SDI Input A and B) .....	5
2.1.2. Program Video Outputs (3G/HD/SDI OUT A and B).....	5
2.1.3. Monitor Video Output (3G/HD/SDI MON OUT A and B) .....	6
2.1.4. Serial Remote Ports (A, B, C).....	6
2.1.4.1. Configuring Ports for RS-232 .....	6
2.1.4.2. Configuring Ports for RS-422 .....	8
2.1.5. Modem .....	9
2.1.6. Ethernet Network Connections .....	9
2.1.7. GPI/GPO Connector.....	10
<b>2.2. GPI/O SETUP .....</b>	<b>11</b>
<b>2.3. SERVICING INSTRUCTIONS.....</b>	<b>11</b>
2.3.1. Replacing the Battery .....	11
2.3.1.1. Safety Guidelines and Precautions Concerning the Use of 3V Lithium Batteries .....	11
<b>3. TECHNICAL SPECIFICATIONS.....</b>	<b>13</b>
<b>3.1. SERIAL DIGITAL VIDEO INPUT .....</b>	<b>13</b>
<b>3.2. SERIAL DIGITAL VIDEO OUTPUT.....</b>	<b>13</b>
<b>3.3. GENERAL PURPOSE IN/OUT .....</b>	<b>13</b>
<b>3.4. COMMUNICATIONS AND CONTROL.....</b>	<b>13</b>
<b>3.5. ELECTRICAL.....</b>	<b>13</b>
<b>3.6. ORDERING OPTIONS.....</b>	<b>14</b>
<b>4. CARD-EDGE MONITORING .....</b>	<b>15</b>
<b>4.1. STATUS INDICATOR LEADS .....</b>	<b>15</b>
4.1.1. Main Board LED Definitions.....	16
4.1.2. Sub-Board LED Definitions.....	16
<b>4.2. DIP SWITCH CONTROLS .....</b>	<b>17</b>

<b>5.</b>	<b>VISTALINK® CONFIGURATION.....</b>	<b>19</b>
5.1.	WHAT IS VISTALINK®?.....	19
5.2.	VIDEO TAB.....	20
5.2.1.	Video A .....	20
5.2.1.1.	Setting the Video Standard .....	20
5.2.1.2.	Viewing the Detected Standard .....	20
5.2.1.3.	Setting the Bypass Relay .....	21
5.2.2.	Broadcast Control.....	21
5.2.2.1.	Broadcast Flag Control .....	21
5.2.2.2.	Broadcast Flag Embed Line .....	21
5.2.2.3.	Actual Embed Line .....	21
5.3.	CC SETUP .....	22
5.3.1.	CC Setup Control .....	22
5.3.1.1.	SD CEA-608 F1 and F2 Keyers .....	22
5.3.1.2.	VANC Keyer.....	23
5.3.1.3.	Caption Erase Timer .....	23
5.3.1.4.	SD CEA-608 Waveform Line.....	23
5.3.1.5.	SD CEA-608 Waveform Setup Shift.....	23
5.3.2.	Caption Shift Control .....	24
5.3.2.1.	Caption Shift Up GPI.....	24
5.3.2.2.	Caption Shift Up Lines .....	24
5.3.3.	Test Message Enable.....	24
5.3.3.1.	CEA-608 Test Msg.....	24
5.3.3.2.	CEA-708 Test Msg.....	24
5.3.4.	Service Inactive Duration.....	25
5.4.	UPSTREAM CC .....	26
5.4.1.	Upstream CC .....	26
5.4.2.	Block PVR Data Control .....	27
5.4.3.	Upstream CEA-608 Svc Control .....	27
5.4.4.	Upstream CEA-708 Svc Control .....	27
5.4.5.	Stream Monitor.....	27
5.4.5.1.	Upstream F1 .....	27
5.4.6.	Stream Usage Monitor .....	27
5.4.6.1.	Upstream .....	27
5.5.	CDP SETUP.....	28
5.5.1.	CDP Setup .....	29
5.5.1.1.	CDP Embed Mode .....	29
5.5.1.2.	CDP Embed Line .....	29
5.5.1.3.	Swap CDP F1 F2 .....	29
5.5.1.4.	Include Time Code / Service Info Section.....	29
5.5.2.	Service Info Setup.....	29
5.5.2.1.	Configuring the Service Info Section .....	29
5.6.	TRANSLATOR.....	30
5.6.1.	Translator Global Control Svc .....	30

5.6.2.	Translate 608 to 708 Svc.....	30
<b>5.7.</b>	<b>OSD / MONITORING .....</b>	<b>31</b>
5.7.1.	OSD A Mode .....	31
5.7.2.	708 Decode Service .....	31
5.7.2.1.	CEA-708 Decoder Specifications and Limitations.....	32
5.7.3.	608 Decode CC.....	32
5.7.4.	608 Decode Text.....	32
5.7.5.	Text Window Top Row .....	32
5.7.6.	Text Window Height .....	33
5.7.7.	608 Decode XDS.....	33
5.7.8.	XDS Window Top Row.....	33
5.7.9.	XDS Window Height.....	33
5.7.10.	Caption Text Comparison.....	33
5.7.10.1.	Compare A/B Input.....	33
5.7.10.2.	Compare A/B Service.....	33
5.7.10.3.	Delay Alarm.....	33
5.7.10.4.	Error Alarm.....	33
5.7.10.5.	Average Delay.....	34
5.7.10.6.	Errors/Minute.....	34
<b>5.8.</b>	<b>COMM PORTS .....</b>	<b>35</b>
5.8.1.	Super Port Select .....	36
5.8.2.	Port x Setup (x= A, B, C, D) .....	36
5.8.2.1.	Port x Mode.....	36
5.8.2.2.	Port x Baud .....	36
5.8.2.3.	Port x Comms .....	37
5.8.2.4.	Port x Enable.....	37
5.8.3.	Port x Inactivity Reset.....	37
5.8.4.	Port x Permission (x= A, B, C, D) .....	38
5.8.5.	Text Out Service.....	38
5.8.6.	UDP ASCII Text Streaming .....	38
5.8.6.1.	Client IP Address .....	38
5.8.6.2.	Text Out Port.....	38
5.8.6.3.	Stream Enable .....	38
<b>5.9.</b>	<b>TELNET PORTS.....</b>	<b>39</b>
5.9.1.	Telnet Login .....	40
5.9.2.	Disconnect Timeout.....	40
5.9.3.	Telnet x Setup .....	40
5.9.3.1.	Telnet x Mode .....	40
5.9.3.2.	Telnet x Enable .....	40
5.9.3.3.	Telnet x Inactivity Reset .....	40
5.9.3.4.	TCP Port Control.....	41
5.9.4.	Telnet x Permission.....	41
<b>5.10.</b>	<b>TELNET CLIENT .....</b>	<b>41</b>
5.10.1.	Telnet Client .....	41
<b>5.11.</b>	<b>GPI/O.....</b>	<b>42</b>
5.11.1.	GPI A to F Active Level .....	42

5.11.2.	GPO 1 to 4 Active Level .....	43
5.11.3.	GPO 1 to 4 Assert Delay .....	43
5.11.4.	GPO 1 to 4 De-assert Delay .....	43
5.11.5.	GPO 1 to 4 Stimulus .....	44
<b>5.12.</b>	<b>AFD CONTROL .....</b>	<b>45</b>
5.12.1.	AFD Embed Mode .....	45
5.12.2.	AFD Embed Line .....	46
5.12.3.	AFD Code .....	46
5.12.4.	AFD Aspect Ratio .....	47
5.12.5.	AFD Bar Setting .....	47
5.12.6.	AFD Bar Size 1 .....	48
5.12.7.	AFD Reserved Data Word Enabling .....	48
5.12.8.	GPI x Mode (x=A-F) .....	49
5.12.9.	GPI x Aspect Ratio (x=A-F) .....	49
5.12.10.	GPI x AFD Code (x=A-F) .....	49
5.12.11.	GPI x AFD Bar Setting (x=A-F) .....	49
5.12.12.	GPI x AFD Bar Size 1 (x=A-F) .....	49
<b>5.13.</b>	<b>TIME .....</b>	<b>50</b>
5.13.1.	VITC/ATC .....	50
5.13.1.1.	VITC Line Number .....	50
5.13.1.2.	Timecode Time Type .....	50
5.13.1.3.	VITC/ATC Timecode .....	50
5.13.1.4.	Timecode Status .....	51
5.13.2.	Network Time Protocol .....	51
5.13.2.1.	NTP Server IP Address .....	51
5.13.2.2.	NTP Poll Enable .....	51
5.13.2.3.	NTP Timecode .....	51
5.13.2.4.	NTP Status .....	51
5.13.3.	Real Time Clock .....	51
5.13.3.1.	UTC Time .....	51
5.13.3.2.	UTC Date .....	51
5.13.3.3.	DST In Effect .....	51
5.13.3.4.	DST Observed .....	52
5.13.3.5.	Timezone .....	52
5.13.3.6.	RTC Jam to Timecode .....	52
5.13.4.	Effective Time .....	52
5.13.4.1.	Timecode Source .....	52
5.13.4.2.	Timecode Offset .....	52
5.13.4.3.	Effective Timecode .....	52
<b>5.14.</b>	<b>SYSTEM .....</b>	<b>53</b>
5.14.1.	Modem Speaker .....	53
5.14.2.	Save Preset .....	53
5.14.3.	Recall Preset .....	53
5.14.4.	Clear Non-Volatile XDS .....	53
5.14.5.	IP Address .....	54
5.14.6.	Netmask .....	54
5.14.7.	Broadcast .....	54
5.14.8.	Gateway .....	54

5.14.9. Firmware Version .....	54
5.14.10. Board Information.....	54
<b>5.15. COMPACT FLASH .....</b>	<b>55</b>
5.15.1. Data Capture .....	55
5.15.1.1. CEA-608 .....	55
5.15.1.2. Procap.....	56
5.15.1.3. CDP/RP2007 (Caption Distribution Packets).....	56
5.15.1.4. SCC (Scenarist Closed Captions) .....	56
5.15.1.5. Port .....	56
5.15.2. Data Encode .....	56
<b>5.16. FAULTS.....</b>	<b>58</b>
5.16.1. Error Messages .....	59
5.16.2. Correcting Caption Errors Automatically.....	62
<b>6. SERIAL COMMAND PROTOCOL.....</b>	<b>63</b>
<b>6.1. COMMAND QUICK REFERENCE .....</b>	<b>63</b>
<b>6.2. COMMAND SYNTAX DESCRIPTION.....</b>	<b>64</b>
6.2.1. Special Characters .....	64
6.2.2. Parameters.....	64
6.2.3. Flow Control Handshaking .....	67
6.2.4. Break Handling.....	67
6.2.5. Command Responses .....	67
<b>6.3. COMMON COMMANDS .....</b>	<b>67</b>
6.3.1. Set Baud Rate .....	67
6.3.2. Reset Encoder.....	68
6.3.3. Set Output Line .....	68
6.3.4. Monitoring Line 21 Data on the Serial Port .....	69
6.3.5. Controlling the Caption Decoder.....	69
6.3.6. Report Firmware Version.....	70
6.3.7. Command Help .....	70
6.3.8. Report Bypass Switch Mode.....	70
6.3.9. Report Battery Status .....	70
6.3.10. Set / Report Time of Day Clock .....	70
6.3.11. Set / Report Calendar Date .....	71
6.3.12. Transparent State.....	72
6.3.13. Null State.....	72
6.3.14. Direct Control State .....	73
6.3.15. Real Time State.....	74
6.3.16. Display System Status.....	74
<b>6.4. TEXT ARTICLES .....</b>	<b>75</b>
6.4.1. Input Article .....	75
6.4.2. Output Article .....	76
6.4.3. Delete Article .....	77
6.4.4. Queue Articles.....	77
6.4.5. Display Article Status.....	78

---

6.4.6.	Display Output Queue .....	78
<b>6.5.</b>	<b>EXTENDED DATA SERVICES .....</b>	<b>79</b>
6.5.1.	Input XDS.....	79
6.5.2.	Blocking Upstream XDS Packets .....	80
6.5.3.	Queue XDS Packets .....	81
6.5.4.	Delete XDS Packet.....	81
6.5.5.	Inserting XDS Articles into Non-Volatile Memory.....	81
<b>6.6.</b>	<b>COMM PORT CONTROL COMMANDS .....</b>	<b>81</b>
6.6.1.	Show Port Permission Maps.....	82
6.6.2.	Alter Port Permission Maps .....	82
6.6.3.	Show Port Active Maps .....	83
6.6.4.	Alter Port Active Maps.....	83
6.6.5.	Reset Port .....	84
<b>7.</b>	<b>TROUBLESHOOTING .....</b>	<b>85</b>
<b>7.1.</b>	<b>ANSWERS TO FREQUENTLY ASKED QUESTIONS .....</b>	<b>85</b>
7.1.1.	Which Serial Port Should I Connect To? .....	85
7.1.2.	There is No SDI Video Present on the SDI Output .....	85
7.1.3.	How Do I Check if Captions are Being Processed?.....	85
7.1.3.1.	Control A Protocol Test Using a Terminal Program.....	85
7.1.4.	There are No Captions Present Out of the ATSC Encoder.....	86
7.1.5.	What Baud Rate and Port Settings Should I Use? .....	87
7.1.6.	Captions are Not Being Encoded At All .....	87
7.1.7.	Captions are Not Being Encoded Correctly .....	87
7.1.8.	How Can I Block Upstream Captions? .....	88
7.1.9.	How Can I Pass Upstream Captions? .....	88
7.1.10.	My Modem Connection Hangs-Up Unexpectedly .....	88
<b>7.2.</b>	<b>BEFORE YOU CALL EVERTZ TECHNICAL SUPPORT .....</b>	<b>89</b>
<b>8.</b>	<b>GLOSSARY.....</b>	<b>91</b>
<b>8.1.</b>	<b>GLOSSARY OF STANDARDS .....</b>	<b>91</b>
<b>8.2.</b>	<b>GLOSSARY OF TERMS.....</b>	<b>92</b>

**Figures**

Figure 1-1: 7825CCE-3G Block Diagram .....	2
Figure 2-1: 7825CCE-3G Rear Plate.....	5
Figure 2-2: RS-232 DTE Configuration (A7725/A hardware) .....	7
Figure 2-3: RS-232 DTE Configuration (A7725/C hardware) .....	7
Figure 2-4: Wiring RS-232 DTE Serial Port to Computer .....	7
Figure 2-5: RS-422 Tributary Configuration (A7725/A hardware) .....	8
Figure 2-6: RS-422 Tributary Configuration (A7725/C hardware) .....	8
Figure 2-7: Wiring RS-422 Tributary Serial Port to RS-422 Controller .....	9
Figure 2-8: GPIO Connector.....	10
Figure 4-1: 7825CCE-3G Card-Edge .....	15
Figure 5-1: VistaLINK <sup>®</sup> Video Tab .....	20
Figure 5-2: VistaLINK <sup>®</sup> CC Setup Tab.....	22
Figure 5-3: VistaLINK <sup>®</sup> Upstream CC Tab .....	26
Figure 5-4: VistaLINK <sup>®</sup> CDP Setup Tab .....	28
Figure 5-5: VistaLINK <sup>®</sup> Translator Tab .....	30
Figure 5-6: VistaLINK <sup>®</sup> OSD Tab.....	31
Figure 5-7: VistaLINK <sup>®</sup> COMM Ports Tab.....	35
Figure 5-8: VistaLINK <sup>®</sup> Telnet Ports Tab .....	39
Figure 5-9: VistaLINK <sup>®</sup> GPI/O Tab .....	42
Figure 5-10: GPIO Functionality .....	43
Figure 5-11: VistaLINK <sup>®</sup> AFD Control Tab.....	45
Figure 5-12: AFD Control Codes .....	46
Figure 5-13: VistaLINK <sup>®</sup> AFD Control Tab continued.....	48
Figure 5-14: VistaLINK <sup>®</sup> Time Tab .....	50
Figure 5-15: VistaLINK <sup>®</sup> System Tab .....	53
Figure 5-16: Compact Flash Tab.....	55
Figure 5-17: VistaLINK <sup>®</sup> Faults Tab.....	58
Figure 6-1: Command Quick Reference.....	63

**Tables**

Table 2-1: Standard RJ45 Wiring Colour Codes .....	10
Table 4-1: Main Board LEDs .....	16
Table 4-2: Sub-Board LEDs.....	16
Table 4-3: DIP Switch Functions .....	17
Table 5-1: 7825CCE-3G CEA-708 Decoder Specifications and Limitations .....	32
Table 5-2: Output Options .....	36
Table 5-3: Port Enable Options .....	37
Table 5-4: CDP Non-fatal Errors .....	59
Table 5-5: CDP Fatal Errors .....	59
Table 5-6: Operational Errors .....	60
Table 5-7: Serial Command Protocol Errors.....	60
Table 5-8: SMPTE-333 Errors .....	61
Table 5-9: Caption Delay Errors .....	61
Table 5-10: Caption Service Inactive Errors.....	61

## REVISION HISTORY

<u>REVISION</u>	<u>DESCRIPTION</u>	<u>DATE</u>
1.0	Internal Draft	Apr 2009
1.1	Internal Draft	May 2009
1.2	First Release	Jun 2009
1.2.1	Added Main board and Sub-board LEDs definitions, and Error Message descriptions. Updated Real Time State Information in section 6.3.15	Oct 2009
1.2.2	Added Telnet Ports information to VistaLINK Configuration section	Feb 2012
1.2.3	Updated 'Translate 608 to 708 Svc' section	Oct 2012
1.2.4	Added section 5.15.2 Correcting Caption Errors Automatically	Oct 2013
1.3	Serial port pinouts for A7725/C hardware. Updated power spec.	Dec 2013
1.4	Updates throughout	Feb 2015

Information contained in this manual is believed to be accurate and reliable. However, Evertz assumes no responsibility for the use thereof nor for the rights of third parties, which may be affected in any way by the use thereof. Any representations in this document concerning performance of Evertz products are for informational use only and are not warranties of future performance, either expressed or implied. The only warranty offered by Evertz in relation to this product is the Evertz standard limited warranty, stated in the sales contract or order confirmation form.

Although every attempt has been made to accurately describe the features, installation and operation of this product in this manual, no warranty is granted nor liability assumed in relation to any errors or omissions unless specifically undertaken in the Evertz sales contract or order confirmation. Information contained in this manual is periodically updated and changes will be incorporated into subsequent editions. If you encounter an error, please notify Evertz Customer Service department. Evertz reserves the right, without notice or liability, to make changes in equipment design or specifications.



## 1. OVERVIEW

The model 7825CCE-3G 3G/HD/SD-SDI DTV Closed Caption Encoder expands on the professional line of closed captioning solutions by Evertz. The 7825CCE-3G supports both dual and simultaneous CC encoding paths supporting 3G/HD/SD-SDI video signals. This unit has native support for numerous captioning interfaces, such as captioning over dial-up phone line, captioning over IP, captioning over serial RS-232/422 and caption bridging from one input to the other. Applications such as "translating" captions from CEA-608 line 21 to CEA-708 VANC captions or "transcoding" CEA-708 captions to CEA-608 line 21 captions are natively supported.

The 7825CCE-3G supports many advanced applications such as, broadcast flag insertion, port echo capability for daisy chaining multiple units together and on-screen display for real time decode of the encoded closed captions.

The 7825CCE-3G is VistaLINK<sup>®</sup>-capable, which allows for control and configuration via Simple Network Management Protocol (SNMP). This offers the flexibility to manage the module status monitoring and configuration from SNMP enabled control systems such as Evertz VistaLINK<sup>®</sup>Pro locally or remotely.

### Features and Benefits:

- Simultaneous encoding of new CEA-608 and CEA-708 captions onto 3G/HD/SD-SDI video
- Port Echo capability for closed caption encoder "daisy chain" set-up
- CEA-608 (Line 21) VBI bridge functionality
- CEA-708 Advance caption bridge functionality
- Supports SMPTE 333, Grand Alliance and RP2007 serial transfer formats for caption data
- Support for CEA-608 (Line 21) captions on SD-SDI video
- Support for SMPTE 334 VANC captions onto 3G/HD-SDI video
- Supports captioning over IP
- Broadcast Flag and AFD VANC packet insertion
- RS-232/422 serial, telephone modem, Ethernet TCP/IP and parallel GPI interfaces
- Built-in CEA-708 and CEA-608 closed caption monitoring decoder
- Closed caption shifting to avoid overlapping emergency crawl messages
- Easy configuration via VistaLINK<sup>®</sup> Pro
- Encoding of Extended Data Service (XDS) packets, including Transmission Signal Identifier (TSID), Copy Generation Management System (CGMS-A) and Program Rating (V-Chip)
- Automatic validation and correction of common captioning errors

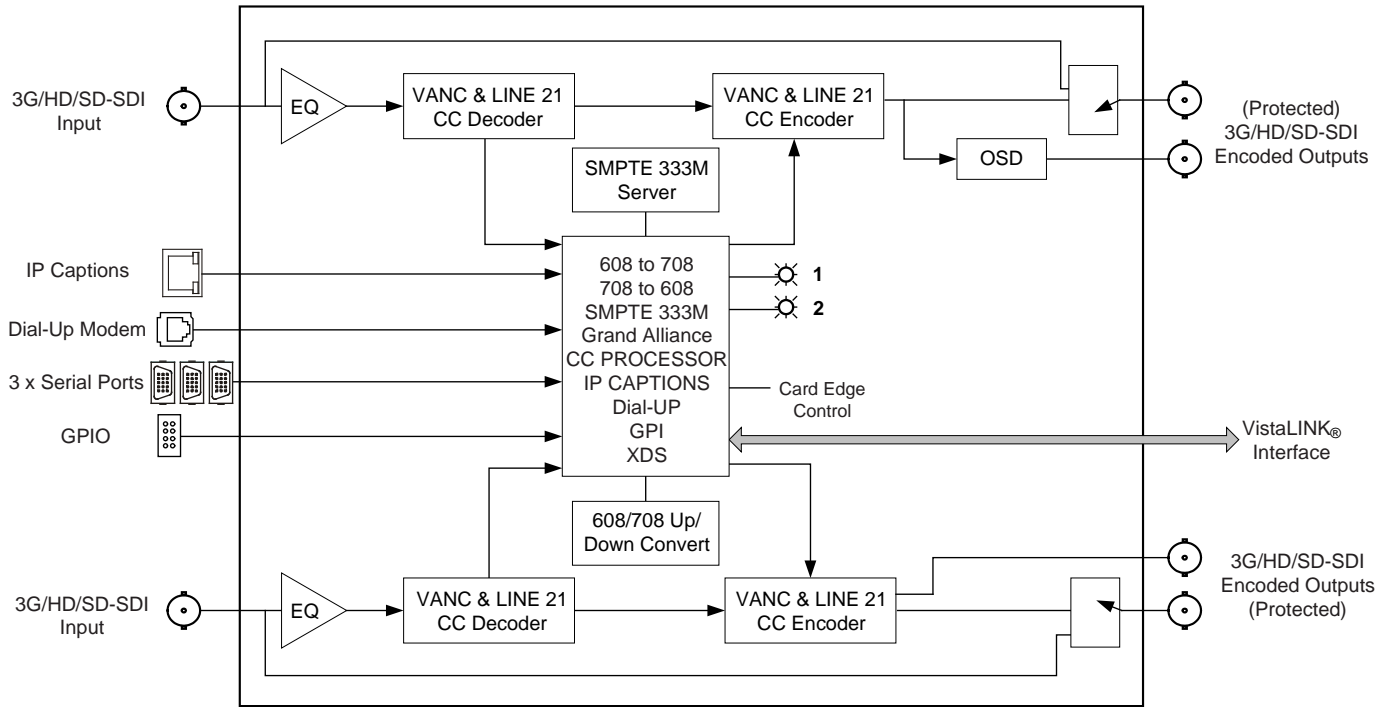

**Figure 1-1: 7825CCE-3G Block Diagram**

## 1.1. HOW TO USE THIS MANUAL

This manual is organized into 8 chapters: Overview, Installation, Technical Specifications, Card Edge Monitoring, VistaLINK® Configuration, Serial Protocol, Troubleshooting, and Glossary.

Chapter 1 provides a brief overview of the 7825CCE-3G operation and features.

Chapter 2 provides a detailed description of the rear panel connectors and how the 7825CCE-3G should be connected into your system.

Chapter 3 provides technical information such as the specifications.

Chapter 4 provides card edge information such as status LEDs and DIP switch controls.

Chapter 5 provides information regarding VistaLINK® configuration and settings.

Chapter 6 provides information about the serial command protocol used for external devices to communicate with the 7825CCE-3G.

Chapter 7 provides a brief troubleshooting guide and answers to frequently asked questions. Consult this chapter before you call Evertz technical support.

Chapter 8 contains a glossary that defines concepts and terms used throughout the remainder of the manual. We highly recommend taking the time to become familiar with the terms and concepts described here before proceeding into the rest of the manual.



This symbol is intended to alert the user to important operating instructions.



The exclamation point within an equilateral triangle is intended to alert the user to the presence of important safety related operating and maintenance (Servicing) instructions in this manual.

*This page left intentionally blank*

## 2. INSTALLATION

### 2.1. REAR PANEL

Figure 2-1 provides the user with an illustration of the 7825CCE-3G rear plate. The 7825CCE-3G rear plate occupies 2 slots in a 3RU 7700FR/7800FR MultiFrame. Please see section 3 of the MultiFrame manuals for more information on installing the rear plate into the frame.

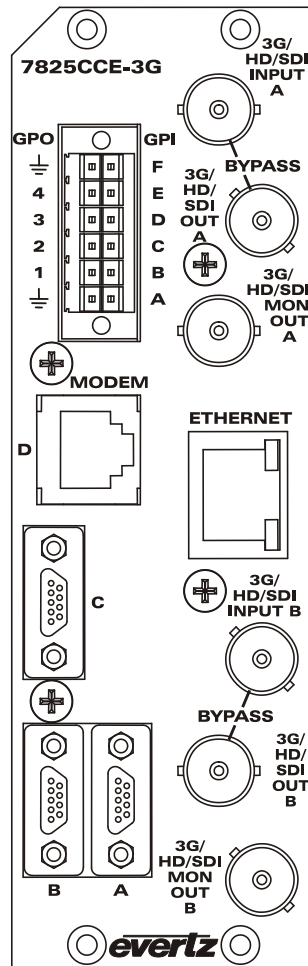

**Figure 2-1: 7825CCE-3G Rear Plate**

#### 2.1.1. Program Video Inputs (3G/HD/SDI Input A and B)

The SDI inputs A and B are BNCs compatible with SMPTE 259M-C, SMPTE 292M and SMPTE 425M format(s). These inputs support upstream SDI video and upstream SDI video with caption information. The bypass relay comes standard with the 7825CCE-3G and is enabled using VistaLINK® controls.

#### 2.1.2. Program Video Outputs (3G/HD/SDI OUT A and B)

The SDI outputs A and B are single BNCs compatible with SMPTE 259M-C, SMPTE 292M and SMPTE 425M format(s).

### **2.1.3. Monitor Video Output (3G/HD/SDI MON OUT A and B)**

1 BNC connector for output of SDI signals. This output is identical to the PGM SDI output except it is not bypass protected. If the bypass relay is activated, this connector will have NO video output. The MON out provides the capability of adding decoded CEA-608 or CEA-708 captions burned over the video. Please note this is available on **Monitor Video Output A** only. Decoder options are configured using VistaLINK®.

### **2.1.4. Serial Remote Ports (A, B, C)**

Three serial ports, labelled A, B and C, are available on the rear panel. These use “Micro-D” connectors. The 7825CCE-3G is shipped with adapter cables to convert these to standard male “DB9” connectors for connection to a computer or captioning equipment.

The serial ports can be used for a variety of functions, including Control-A, SMPTE 333, Grand Alliance, and RP2007 protocols. VistaLINK® is used to set the functionality, baud rate, word size and parity for your application.



**Connecting the 7825CCE-3G to an ATSC encoder may require a null modem cable or straight-through cable. Please check the ATSC encoder manual or contact the ATSC encoder manufacturer for the correct cable type.**

**Do not use “gender changers” or in-house fabricated cables to connect the 7825CCE-3G to the ATSC encoder. Always use a store-bought Null or Straight through cable connected directly from the 7825CCE-3G to the ATSC encoder.**

Physically, each serial port can be independently configured for either RS-232 “DTE” or RS-422 “tributary” logic levels and pinouts. As configured from the factory, all serial ports are configured for RS-232 logic levels. The DTE pin-out provides easy connection to RS-232 serial ports on most equipment via a store-bought null-modem cable or straight-through cable.

#### **2.1.4.1. Configuring Ports for RS-232**

Ports A, B, and C are configured for RS-232 communications from the factory. The two common RS-232 pinouts are Data Terminal Equipment (DTE) and Data Communications Equipment (DCE). In RS-232 mode, the 7825CCE-3G serial ports have a DTE pinout, as shown in Figure 2-4.

Depending on your revision of hardware, your 7825CCE-3G may have serial port configuration headers that resemble those in Figure 2-2 or Figure 2-3.

If the serial port headers resemble those in Figure 2-2, set the 7825CCE-3G’s serial ports to RS-232 by performing the following steps:

1. Move the jumpers on **J8, J9 or J10** to the “232 DTE” position.
2. Move **DIP switch 1, 2, or 3** to the OPEN position.

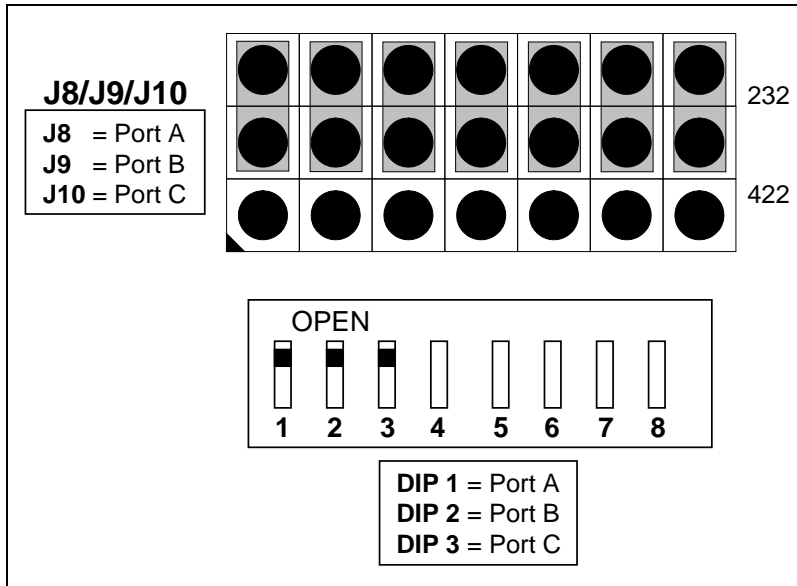

**Figure 2-2: RS-232 DTE Configuration (A7725/A hardware)**

If the serial port headers resemble those in Figure 2-3, set the 7825CCE-3G's serial ports to RS-232 by moving the jumpers on **J16**, **J8** or **J9** to the positions shown in the figure.

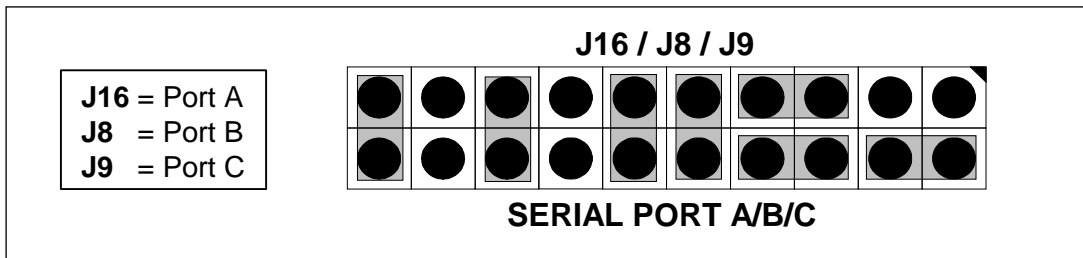

**Figure 2-3: RS-232 DTE Configuration (A7725/C hardware)**

Serial Port (A,B,C)	Computer End				
	Male (pins)		Male (pins)		Description
Description	DB9		DB25	DB9	
Shield					Shield
RS 232 Transmit	3	-----	3	2	RS 232 Receive
Ground	5	-----	7	5	Signal Ground
RS 232 Receive	2	-----	2	3	RS 232 Transmit
RS 232 CTS	8	-----	4	7	RS 232 RTS
RS 232 DTR	4	-----	6	6	RS 232 DSR
RS 232 RTS	7	-----	5	8	RS 232 CTS
RS 232 DSR	6	-----	20	4	RS 232 DTR

**Figure 2-4: Wiring RS-232 DTE Serial Port to Computer**

**2.1.4.2. Configuring Ports for RS-422**

Ports A, B, and C are separately configurable for RS-422 communication. The two common RS-422 pinouts are “Controller” and “Tributary”. The Tributary pinout is also known as “Device” pinout. In RS-422 mode, the 7825CCE-3G serial ports have a “Tributary” pinout, as shown in Figure 2-7.

Depending on your revision of hardware, your 7825CCE-3G may have serial port configuration headers that resemble those in Figure 2-5 or Figure 2-6.

If the serial port headers resemble those in Figure 2-5, set the 7825CCE-3G's serial ports to RS-422 by performing the following steps:

1. Move the jumpers on **J8, J9 or J10** to the “422 TRIB” position.
2. Move **DIP switch 1, 2, or 3** to the CLOSED position.

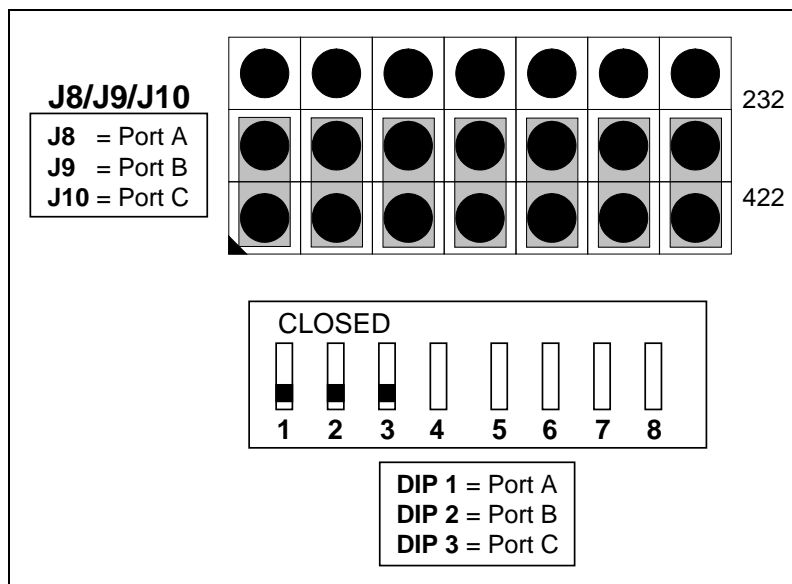

**Figure 2-5: RS-422 Tributary Configuration (A7725/A hardware)**

If the serial port headers resemble those in Figure 2-6, set the 7825CCE-3G's serial ports to RS-232 by moving the jumpers on **J16, J8 or J9** to the positions shown in the figure.

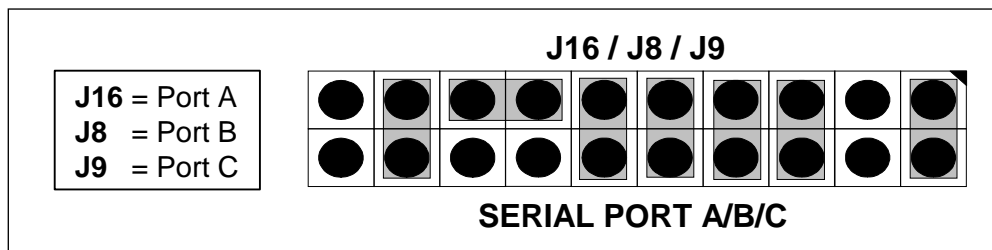

**Figure 2-6: RS-422 Tributary Configuration (A7725/C hardware)**



Serial I/O Port (A, B, C)			Computer “Controller” End	
Description	Male (pins)		Female	Description
	DB9		DB9	
Shield				Shield
Frame Ground	1	-----	1	Frame Ground
Transmit Common	6	-----	6	Receive Common
Transmit -	2	-----	2	Receive -
Transmit +	7	-----	7	Receive +
Receive +	3	-----	3	Transmit +
Receive -	8	-----	8	Transmit -
Receive Common	4	-----	4	Transmit Common
Frame Ground	9	-----	9	Frame Ground
not used	5	-----	5	not used

**Figure 2-7: Wiring RS-422 Tributary Serial Port to RS-422 Controller**

### 2.1.5. Modem

The **MODEM D** RJ11 jack is used to connect the internal modem of the 7825CCE-3G to a telephone line, allowing computers at other locations running captioning software to communicate with the 7825CCE-3G. VistaLINK® menus are used to set the correct baud rate, word size and parity for use with your captioning software.



**IMPORTANT INSTALLATION NOTICE: For a reliable telephone connection to the modem in the caption encoder, a direct telephone line must be used. This line must not pass through a PBX or similar key device.**

### 2.1.6. Ethernet Network Connections

The 7825CCE-3G is equipped with an RJ-45 connector for Ethernet network communications. The Ethernet connection can be used for a variety of functions. One of the primary uses of this is as a telnet server connection for inserting captions. The 7825CCE-3G supports a single telnet session, which is configured in the menus as "Port F". Once a telnet session is established, it uses the Control-A protocol (see Section 4), the same as the serial ports and modems.

The 7825CCE-3G is designed to be used with either 10Base-T (10 Mbps) or 100Base-TX (100 Mbps) also known as *Fast Ethernet*, twisted pair Ethernet cabling systems. When connecting for 10Base-T systems, category 3, 4, or 5 UTP cable as well as EIA/TIA – 568 100Ω STP cable may be used. When connecting for 100Base-TX systems, category 5 UTP cable is required. The cable must be “straight through” with a RJ-45 connector at each end. Make the network connection by plugging one end of the cable into the RJ-45 receptacle of the 7825CCE-3G and the other end into a port of the supporting hub.

The straight-through RJ-45 cable can be purchased or can be constructed using the pinout information in Table 2-1. A colour code wiring table is provided in Table 2-1 for the current RJ 45 standards (AT&T 258A or EIA/TIA 258B colour coding shown). Also refer to the notes following the table for additional wiring guide information.

Pin #	Signal	EIA/TIA 568A	AT&T 258A or EIA/TIA 568B	10BaseT or 100BaseT
1	Transmit +	White/Green	White/Orange	X
2	Transmit -	Green/White or White	Orange/White or Orange	X
3	Receive +	White/Orange	White/Green	X
4	N/A	Blue/White or Blue	Blue/White or Blue	Not used (required)
5	N/A	White/Blue	White/Blue	Not used (required)
6	Receive -	Orange/White or Orange	Green/White or Green	X
7	N/A	White/Brown	White/Brown	Not used (required)
8	N/A	Brown/White or Brown	Brown/White or Brown	Not used (required)

**Table 2-1: Standard RJ45 Wiring Colour Codes**

Note the following cabling information for this wiring guide:

- Only two pairs of wires are used in the 8-pin RJ 45 connector to carry Ethernet signals.
- Even though pins 4, 5, 7 and 8 are not used, it is mandatory that they be present in the cable.
- 10BaseT and 100BaseT use the same pins; a crossover cable made for one will also work with the other.
- Pairs may be solid colours and not have a stripe.
- Category 5 cable must use Category 5 rated connectors.

**2.1.7. GPI/GPO Connector**

A 12-pin terminal block connector provides a method of connecting the remote control GPI signals to control the caption encoder. The user can configure the GPI/O functionality of the 7825CCE-3G via VistaLINK® control. The pin assignment of the connector is illustrated in Figure 2-6.



**GPI/O pullup voltage is set to +12V or +5V with J7 on A7725 sub-board.**

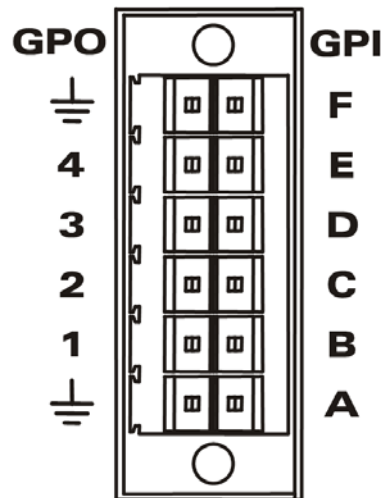

**Figure 2-8: GPIO Connector**

## 2.2. GPIO SETUP

The following features of the 7825CCE-3G can be controlled via GPIO:

- **SD-SDI Field 1 Keyer and Field 2 Keyer;** (Section 5.3.1.1)
- **HD-SDI VANC Keyer Ctrl;** (Section 5.3.1.2)
- **Upstream Caption Source Selection;** (Section 5.4.3)
- **GPIO Caption Shift;** (Section 5.3.2)
- **Port Enable/Disable;** (Section 5.8)
- **GPO Output Configuration;** (Section 5.9)

## 2.3. SERVICING INSTRUCTIONS



**CAUTION** – These servicing instructions are for use by qualified service personnel only. To reduce risk of electric shock, do not perform any servicing instructions in this section of the manual unless you are qualified to do so.

### 2.3.1. Replacing the Battery

The 7825CCE-3G is fitted with a 3V 20mm diameter Lithium battery type CR2032. This battery is used to power the system time clock while power is removed from the unit. If the unit is not keeping time properly when it is powered down, the battery should be replaced according to the procedure outlined in section 2.3.1.1.

#### 2.3.1.1. Safety Guidelines and Precautions Concerning the Use of 3V Lithium Batteries

Please observe the following warnings strictly. If misused, the batteries may explode or leak, causing injury or damage to the equipment.

- The batteries must be inserted into the equipment with the correct polarity (+ and -).
- Do not attempt to revive used batteries by heating, charging or other means.
- Do not dispose of batteries in fire. Do not dismantle batteries.
- Do not short circuit batteries.
- Do not expose batteries to high temperatures, moisture or direct sunlight.

Do not place batteries on a conductive surface (anti-static work mat, packaging bag or form trays) as it can cause the battery to short.

*This page left intentionally blank*

### 3. TECHNICAL SPECIFICATIONS

#### 3.1. SERIAL DIGITAL VIDEO INPUT

**Standard:** SMPTE 424M 3Gb/s, SMPTE 292M 1.485Gb/s, SMPTE 259M 270Mb/s  
**Number of Inputs:** 2  
**Connector:** BNC per IEC 61169-8 Annex A  
**Equalization:** Automatic up to 80m @3Gb/s with Belden 1694A (or equivalent)  
Automatic up to 100m @1.5Gb/s with Belden 1694A (or equivalent)  
Automatic up to 300m @270Mb/s with Belden 8281 (or equivalent)  
**Impedance:** 75 ohms

#### 3.2. SERIAL DIGITAL VIDEO OUTPUT

**Standard:** Same as input standard  
**Number of Outputs:** 2 per encoding path. Program out is bypass relay protected  
**Connector:** BNC per IEC 61169-8 Annex A  
**Signal Level:** 800mV nominal  
**DC Offset:** 0V  $\pm$  0.5V  
**Rise/ Fall Times:** HD: 200ps nominal  
SD: 740ps nominal  
**Overshoot:** <10% of amplitude  
**Wide Band Jitter:** <0.210 UI @ 1.5Gb/s, < 0.300 UI @ 3Gb/s  
**Impedance:** 75ohms

#### 3.3. GENERAL PURPOSE IN/OUT

**Number of Inputs:** 6  
**Number of Outputs:** 4  
**Type:** Opto-isolated, active low  
**Connector:** 2x6 Terminal Block  
**Signal level:** +5V or +12V nominal

#### 3.4. COMMUNICATIONS AND CONTROL

**Serial:** 3 DB-9 male RS232 / RS422 selectable  
Selectable 1200 baud to 57.6k baud  
7 or 8 data bits  
**Modem:** 1 x RJ-11 telephone jacks 1200 baud to 14.4k baud V.32BIS compatible  
**Ethernet:** IEEE 802.3 (10 BaseT)  
IEEE 802.3u (100 BaseTX)  
RJ-45 connector

#### 3.5. ELECTRICAL

**Voltage:** + 12V DC  
**Power:** 18 Watts  
**EMI/RFI:** Complies with FCC part 15, Class A, EU EMC Directive

### 3.6. ORDERING OPTIONS

**Ordering Options:**

**+CF** Compact Flash card reader for saving and inserting captions from files

**Rear Plate Suffix:** Rear Plate must be specified at time of order (E.g. Model +3RU)  
**+3RU** 3RU rear plate for use with 7800FR, 7700FR-C or 350FR Multiframes

**Enclosures:**

**350FR** 3RU Portable Multiframe which holds up to 7 single slot modules

**7700FR-C** 3RU Multiframe which holds up to 15 single slot modules

**7800FR** 3RU Multiframe which holds up to 15 single slot modules

**4. CARD-EDGE MONITORING**

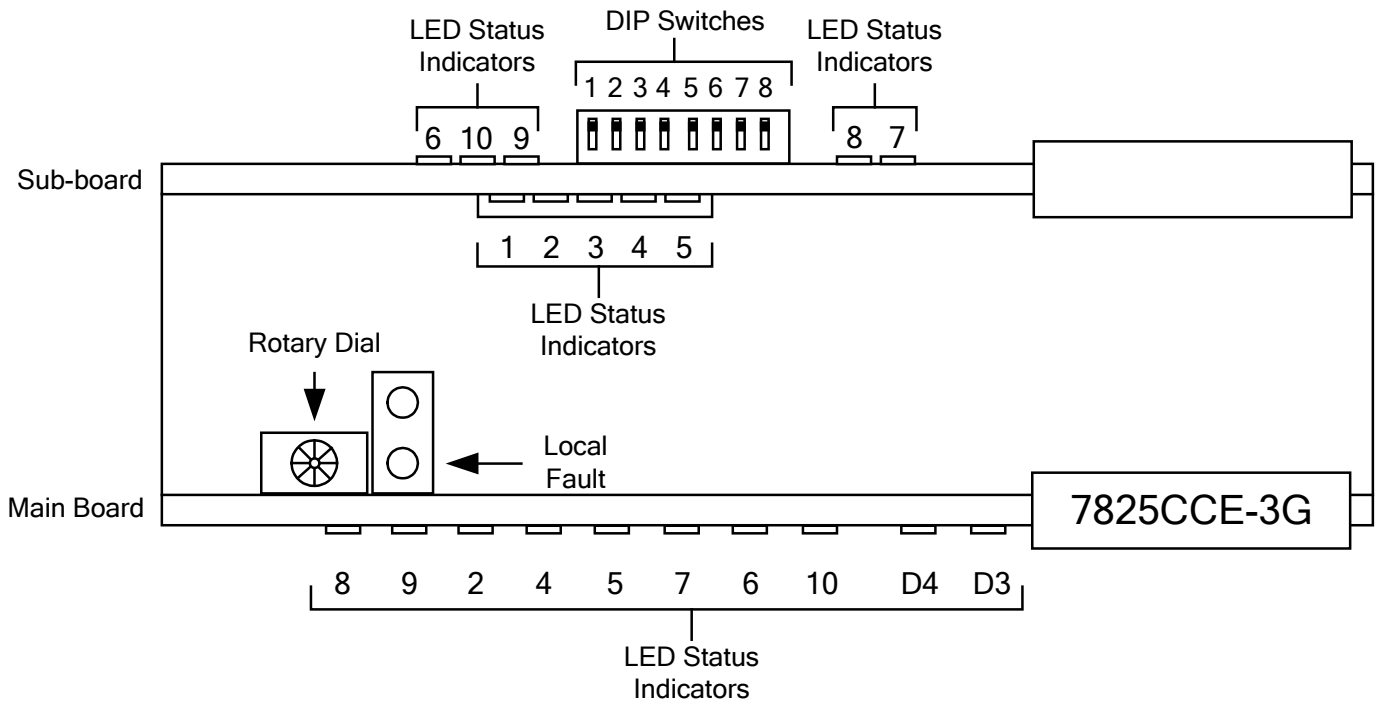

**Figure 4-1: 7825CCE-3G Card-Edge**

**4.1. STATUS INDICATOR LEDES**

Two large LEDs on the front of the board indicate the general health and status of the module.

**LOCAL FAULT:** This Red LED indicates poor module health and will be On if a board power fault exists (i.e.: a blown fuse). The LOCAL FAULT indication can also be reported to the frame through the FRAME STATUS jumper.

**MODULE OK:** This Green LED indicates good module health. It will be On when the board power is good.

**4.1.1. Main Board LED Definitions**

The following table provides the LED definitions for the main board:

LED	DESCRIPTION	DEFINITION
LED 8	Green = Present Red = Not Present Flashing Yellow = Relay Bypass	Video Status for Path A
LED 9	Green = Present Red = Not Present Flashing Yellow = Relay Bypass	Video Status for Path B
LED 2	Green = Connected Red = Error	Modem Connection State
LED 4	-- N/A --	<i>Reserved for future use</i>
LED 5	-- N/A --	<i>Reserved for future use</i>
LED 7	-- N/A --	<i>Reserved for future use</i>
LED 6	-- N/A --	<i>Reserved for future use</i>
LED 10	-- N/A --	<i>Reserved for future use</i>
D3	Green or Off	Ethernet Collision
D4	Off = Not connected Green = Link Flashing = Activity	Ethernet Link/Activity

**Table 4-1: Main Board LEDs**

**4.1.2. Sub-Board LED Definitions**

The following table provides the LED definitions for the sub-board:

LED	DESCRIPTION	DEFINITION
LED 1	Green = Not Present Red = Present	Control-A data in on any comm port (including telnet, modem)
LED 2	Green = Not Present Red = Present	SD Field-1 data out
LED 3	Green = Not Present Red = Present	SD Field-2 data out
LED 4	-- N/A --	<i>Reserved for future use</i>
LED 5	-- N/A --	<i>Reserved for future use</i>
LED 6	-- N/A --	<i>Reserved for future use</i>
LED 7	-- N/A --	<i>Reserved for future use</i>
LED 8	-- N/A --	<i>Reserved for future use</i>
LED 9	-- N/A --	<i>Reserved for future use</i>
LED 10	-- N/A --	<i>Reserved for future use</i>

**Table 4-2: Sub-Board LEDs**



#### 4.2. DIP SWITCH CONTROLS

The 7825CCE-3G is equipped with an 8 position DIP switch to allow the user to select various functions. DIP switch 1 is located at the top of the DIP switch (farthest from to the card ejector). Table 4-3 gives an overview of the DIP switch functions. The On (Closed) position is down, or closest to the printed circuit board.

DIP Switch	Position	Function
1	OPEN	Serial Port A = RS-232.
	CLOSED	Serial Port A = RS-422
2	OPEN	Serial Port B = RS-232.
	CLOSED	Serial Port B = RS-422.
3	OPEN	Serial Port C = RS-232.
	CLOSED	Serial Port C = RS-422.
4	OPEN	Insert CDPs onto SD VANC (same line number as HD VANC where applicable)
	CLOSED	Disable insert of CDPs onto SD VANC
5	OPEN	Currently unassigned. <b>Leave in the OPEN position.</b>
	CLOSED	
6	OPEN	
	CLOSED	
7	OPEN	
	CLOSED	
8	OPEN	
	CLOSED	

**Table 4-3: DIP Switch Functions**

*This page left intentionally blank*

## **5. VISTALINK<sup>®</sup> CONFIGURATION**

### **5.1. WHAT IS VISTALINK<sup>®</sup>?**

VistaLINK<sup>®</sup> is Evertz's remote monitoring and configuration platform which operates over an Ethernet network using Simple Network Management Protocol (SNMP). SNMP is a standard computer network protocol that enables different devices sharing the same network to communicate with each other. VistaLINK<sup>®</sup> provides centralized alarm management, which monitors, reports, and logs all incoming alarm events and dispatches alerts to all the VLPro Clients connected to the server. Card configuration through VistaLINK<sup>®</sup> PRO can be performed on an individual or multi-card basis using simple copy and paste routines, which reduces the time to configure each module separately. Finally, VistaLINK<sup>®</sup> enables the user to configure devices in the network from a central station and receive feedback that the configuration has been carried out.

There are 3 components of SNMP:

1. An SNMP manager, also known as a Network Management System (NMS), is a computer running special software that communicates with the devices in the network. Evertz VL-Fiber demo Manager graphical user interface (GUI), third party or custom manager software may be used to monitor and control Evertz VistaLINK<sup>®</sup> enabled fiber optic products.
2. Managed devices, each with a unique address (OID), communicate with the NMS through an SNMP Agent. Evertz VistaLINK<sup>®</sup> enabled 7700 series modules reside in the 3RU 7700FR-C MultiFrame and communicate with the manager via the 7700FC VistaLINK<sup>®</sup> frame controller module, which serves as the Agent.
3. A virtual database, known as the Management Information Base (MIB), lists all the variables being monitored, which both the Manager and Agent understand. Please contact Evertz for further information about obtaining a copy of the MIB for interfacing to a third party Manager/NMS.

For more information on connecting and configuring the VistaLINK<sup>®</sup> network, see the 7700FC Frame Controller chapter.

## 5.2. VIDEO TAB

The *Video Standard* menu enables the user to choose the SDI upstream video standard.

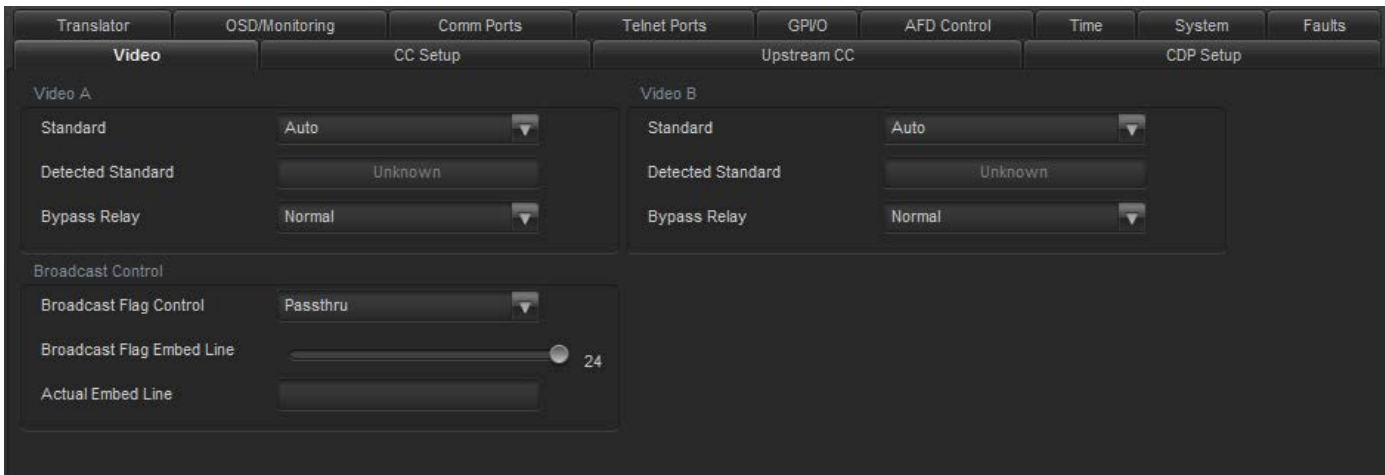

Figure 5-1: VistaLINK® Video Tab

### 5.2.1. Video A

The parameters for **Video A** are identical for **Video B**. For the sake of brevity in the manual, only the options for **Video A** will be discussed in the manual.

#### 5.2.1.1. Setting the Video Standard

**Standard:** The 7825CCE-3G currently supports the following HD/SD/3G SDI standards:

- **Auto (default)**
- 1080i/ 59.94 / 50
- 720p/ 59.94/ 50
- 525i/ 59.94
- 625i/ 50
- 1080p/ 59.94 (425m level-A / level-B)
- 1080p/ 50 (425m level-A / level-B)

#### 5.2.1.2. Viewing the Detected Standard

The ***Detected Standard*** field displays the video standard that is detected.

### 5.2.1.3. Setting the Bypass Relay

The **Bypass Relay** drop down menu enables the user to set the bypass relay to one of the following parameters:

- Normal (default)
- Bypass
- GPI bypass A
- GPI bypass B
- GPI bypass C
- GPI bypass D
- GPI bypass E
- GPI bypass F

### 5.2.2. Broadcast Control

#### 5.2.2.1. Broadcast Flag Control

The **Broadcast Flag Control** enables the user to set the **Broadcast Flag Control** to *Passthru*, *Block*, or *Insert*.

#### 5.2.2.2. Broadcast Flag Embed Line

The **Broadcast Flag Embed Line** enables the user to set the **Flag Embed Line** between 7 and 24 in increments of one.

#### 5.2.2.3. Actual Embed Line

The **Actual Embed Line** field displays the line on which the Flag is embedded.

### 5.3. CC SETUP

The **CC Setup** tab enables the user to configure the Closed Caption settings.

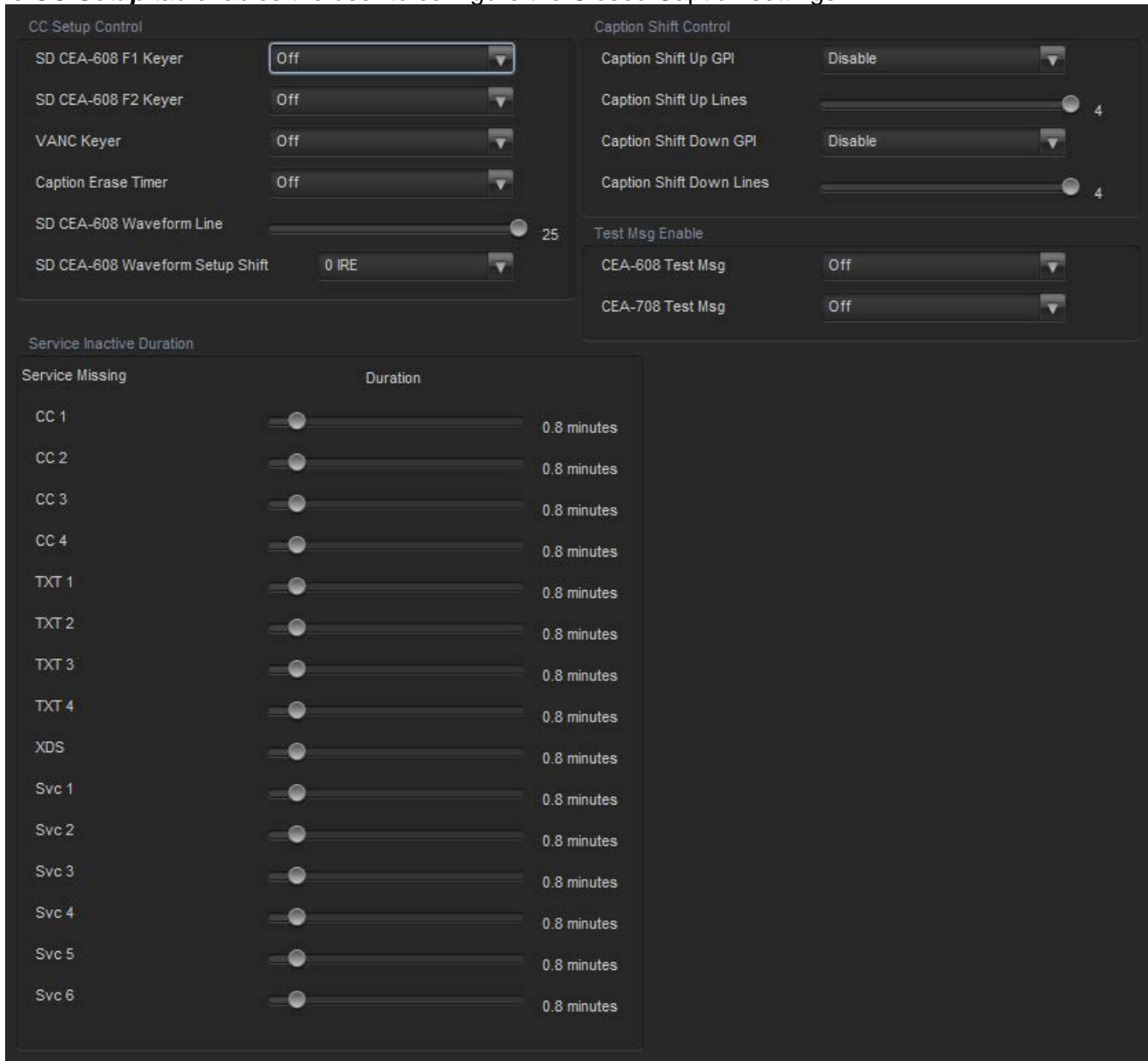
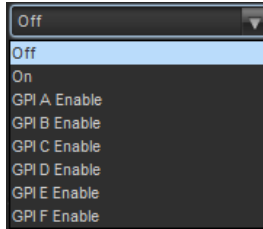

Figure 5-2: VistaLINK® CC Setup Tab

#### 5.3.1. CC Setup Control

##### 5.3.1.1. SD CEA-608 F1 and F2 Keyers

This function allows the user to control the **Field 1 Keyer** using VistaLINK® or via GPI. GPI's A through F are available. Once the GPI is set, the external trigger will now control the **Field 1 Keyer**. The options for **SD CEA-608 F2 Keyer** are identical. For the sake of brevity, only **SD CEA-608 F1 Keyer** will be discussed in the manual.



#### 5.3.1.2. VANC Keyer

This control enables or disables the **VANC Keyer**. This is the global control for selecting whether any VANC data is inserted or altered in HD/3G output video. VANC data includes CDP, AFD, and Broadcast Flag packets. Selecting **VANC Key Off** will disable the VANC keyer and not encode data into the VANC of the HD/3G output. Note that this control has no effect on SD-SDI video.

#### 5.3.1.3. Caption Erase Timer

The **Caption Erase Timer** control is used to erase the caption display. When enabled, the 7825CCE-3G will activate an internal timer and clock the time delay between processing caption data. If caption data is not detected for a period of 15 seconds, the 7825CCE-3G will encode a clear caption command. This command will be used by downstream decoders to clear the caption display. This control can either be enabled or disabled from VistaLINK<sup>®</sup>.

#### 5.3.1.4. SD CEA-608 Waveform Line

The **SD CEA-608 Waveform Line** parameter enables the user to set the waveform line from 10 to 25.

#### 5.3.1.5. SD CEA-608 Waveform Setup Shift

**Setup Shift** is used to select whether the caption data encoded on the downstream SDI video will be shifted to adjust for setup on line 21. It is common for 4:2:2 component to NTSC video encoders to add setup to line 21 regardless of whether there is a closed caption waveform on line 21 or not. The closed caption waveform will be moved up by 7.5 IRE when setup is added by the video encoder. The CEA-608 waveform specification states there should be no setup on line 21.

This control allows the operator to compensate for the setup when the encoding to NTSC video takes place by shifting the caption data down by 7.5 IRE. Note that, in order to shift the caption data down by 7.5 IRE, it is necessary to use digital video values that are not legal according to the SMPTE 125M Component Digital Video specification.

*0 IRE* will encode the caption waveform with a baseline at 0 IRE on 4:2:2 video signals. The resulting closed caption signal will contain legal SMPTE 125 data values, but may have 7.5 IRE of setup added when it is encoded to a composite video signal (depending on the video encoder). *-7.5 IRE* will encode the caption waveform shifted down by -7.5 IRE on 4:2:2 video signals. The resulting line of video will contain illegal SMPTE 125 data values but may have the 7.5 IRE of setup cancelled out when it is encoded to a composite video signal (depending on the video encoder).

### **5.3.2. Caption Shift Control**

#### **5.3.2.1. Caption Shift Up GPI**

This feature allows the user to shift the baseline of the CEA-608 captions up by 2 to 4 lines. This feature is used when weather crawl information is keyed onto the SD-SDI video. GPI's A through F can be selected to enable or disable this function. The **Caption Shift Down GPI** control is identical. For the sake of brevity, only the **Caption Shift Up GPI** control will be discussed in the manual.

#### **5.3.2.2. Caption Shift Up Lines**

This control enables the user to set the baseline of the CEA-608 captions up from 2 to 4. The **Caption Shift Down Lines** control is identical. For the sake of brevity, only **Caption Shift Up Lines** will be discussed in the manual.

### **5.3.3. Test Message Enable**

#### **5.3.3.1. CEA-608 Test Msg**

The **CEA-608 Test Message** is used to test all fields and outputs of the 7825CCE-3G. This function will provide test messages in Field 1 and Field 2 for the SD-SDI output and transcoded test messages on the HD/3G output. If the Translator is configured appropriately, the CEA-608 data will also be translated to CEA-708 data. This function is helpful during troubleshooting procedures.

#### **5.3.3.2. CEA-708 Test Msg**

The **CEA-708 Test Message** provides captions on Services 1 through 4. Each service shows a different caption test pattern. This feature helps users test downstream equipment such as HDTV decoders and ATSC encoders.

#### **Service 1:**

Service 1 provides a 2 window caption roll-up test message. This tests the decoder's ability to process and render multiple caption windows, and rollup captions with bottom-to-top and top-to-bottom scroll directions.

#### **Service 2:**

Service 2 is a background/foreground colour cycle with transparency tests for background. The test message cycles through the different colour and transparency options as specified by CEA-708.

#### **Service 3:**

Service 3 tests caption positioning using a "Bouncing Text" test. The text "TstMsg" is moved around the screen to all possible caption position points. The window text is only refreshed when the window changes direction at the edge of the display. This test exercises the decoder's ability to reposition a pre-defined window containing text.

#### **Service 4:**

Service 4 is an on screen hex dump of the caption character set. The hex dump scrolls bottom to top.



#### **5.3.4. Service Inactive Duration**

The Service Inactive Duration provides the user with controls to set the timeout period before a caption service alarm is raised. There are 15 sliders in this panel which allow the user to set controls for services 608 CC1 to CC4, 608 TXT1 to TXT4, 608 XDS and 708 Svc 1 to Svc 6. The timeout period is displayed in minutes with a range from 0 minutes to 8.5 minutes. These may be configured to assert the GPOs or to generate a Fault Trap if the duration period is exceeded.

## 5.4. UPSTREAM CC

The **Upstream CC** menu is used to setup and configure upstream SDI captions.

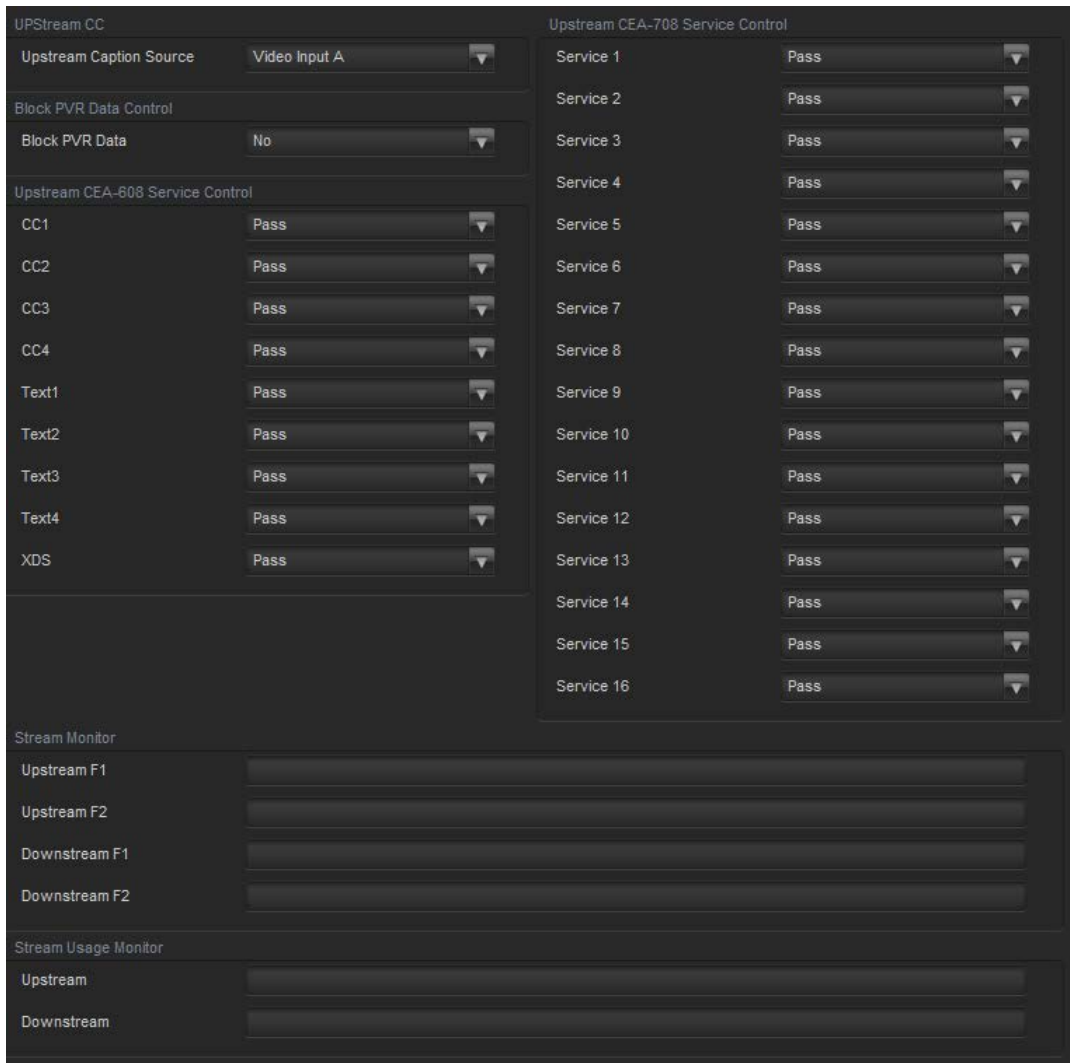
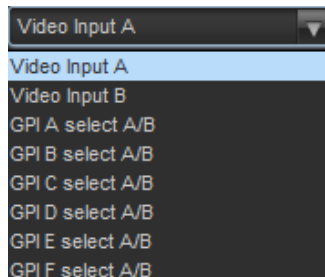

Figure 5-3: VistaLINK® Upstream CC Tab

### 5.4.1. Upstream CC

This control enables the user to set the **Upstream Caption Source**.



When a GPI is selected to control the upstream caption source, video input A will be selected when the corresponding GPI is not asserted. Video input B will be selected when the corresponding GPI is asserted.

#### 5.4.2. Block PVR Data Control

The **Block Personal Video Recorder Data** feature allows the user to remove PVR data control codes from CEA-608 caption data. These codes may have been embedded within CC1 captions. The options include *Yes* or *No*. The default setting for this control is *No*.

#### 5.4.3. Upstream CEA-608 Svc Control

The **Upstream CEA-608 Service Control** allows the user to configure which upstream services to pass. Selectable services include CC1 through CC4, Text1 through Text4, and XDS.

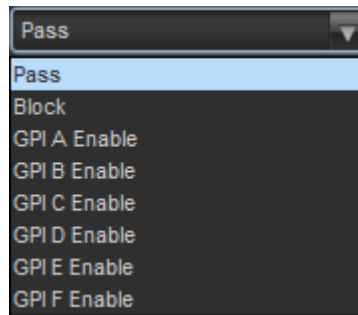

#### 5.4.4. Upstream CEA-708 Svc Control

The **Upstream CEA-708 Service Control** allows the user to configure which upstream services to pass. Selectable services include Svc1 through Svc16.

#### 5.4.5. Stream Monitor

##### 5.4.5.1. Upstream F1

This field displays the status of the Stream being viewed. The **Upstream F2, Downstream F1 and Downstream F2** fields are identical. For the sake of brevity, only **Upstream F1** will be discussed in the manual.

#### 5.4.6. Stream Usage Monitor

##### 5.4.6.1. Upstream

This field displays the usage of the associated Stream. The **Downstream** field is identical. For the sake of brevity, only **Upstream** will be discussed in the manual.

### 5.5. CDP SETUP

The **CDP Setup** menu, as illustrated in Figure 5-4, enables the user to configure the encoding of Caption Distribution Packets (CDPs) in the VANC area of HD/3G video.

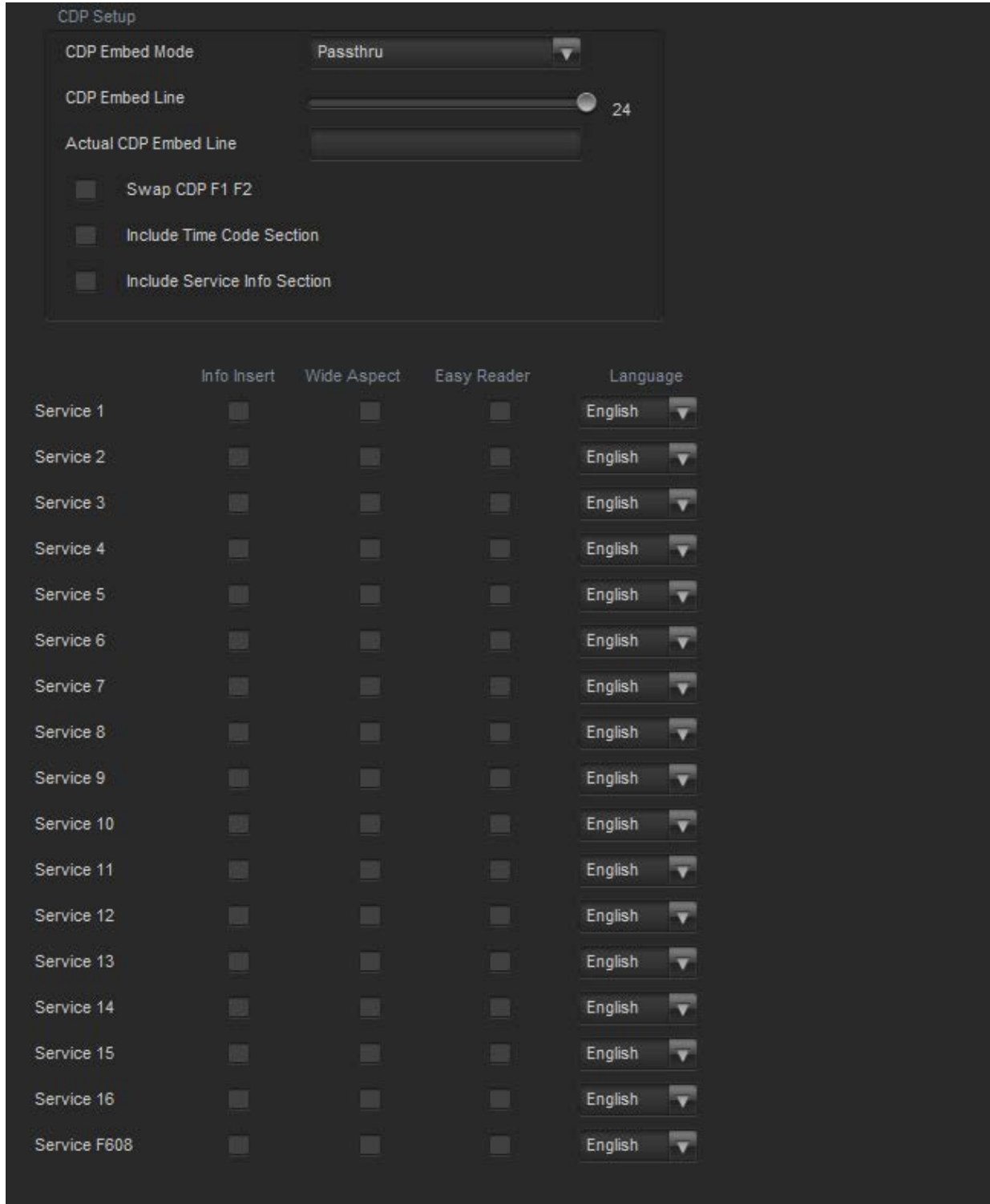

Figure 5-4: VistaLINK® CDP Setup Tab

## 5.5.1. CDP Setup

### 5.5.1.1. CDP Embed Mode

The **CDP Embed Mode** control enables the user to set the **Embed Mode** to *Passthru*, *Block*, or *Insert*. Note that this control has no effect if the VANC Keyer is off.

### 5.5.1.2. CDP Embed Line

The **CDP Embed Line** control enables the user to set the **Embed Line** from 7 to 24 in increments of one.

### 5.5.1.3. Swap CDP F1 F2

Certain compression encoders require that the order of CEA-608 field-1 and field-2 data is reversed when encoding in CDPs. This control can either be enabled or disabled. We recommend leaving this setting Disabled unless specifically instructed by the compression encoder manufacturer. This control only affects CDPs targeted for an insert rate of 25, 29.97 and 30 fps, which includes 1080i/50, 1080i/59.94 and 1080i/60.

### 5.5.1.4. Include Time Code / Service Info Section

These parameters allow the user to select whether to include these optional data sections in the CDPs encoded by the 7825CCE-3G. The default settings for these controls are disabled.

## 5.5.2. Service Info Setup

The *Service Info* setup allows the user to configure the data that will be encoded in the *Service Info* section of the CDP. The optional *Service Info* section describes the captions that are encoded in the video. Receivers may use the service information generated by the 7825CCE-3G for a variety of different functions.

### 5.5.2.1. Configuring the Service Info Section

**INFO INSERT:** This checkbox indicates that the *Service Info* section will include caption service description data for the indicated caption service. Only enable Service Info for caption services that are actually present in the video.

**WIDE ASPECT:** The *Wide Aspect Ratio* flag indicates that the closed captions on the indicated caption service are formatted with up to 42 characters per line for improved display on wide aspect ratio displays.

**EASY READER:** The *Easy Reader* flag indicates that the indicated caption service contains simplified “easy reader” closed captions. Easy reader captions are for viewers with a lower vocabulary level (e.g. children).

**LANGUAGE:** The Service Info section includes a field that describes the language for each caption service. The dropdown menu allows the operator to select one of three *Languages*: English, French, and Spanish.

## 5.6. TRANSLATOR

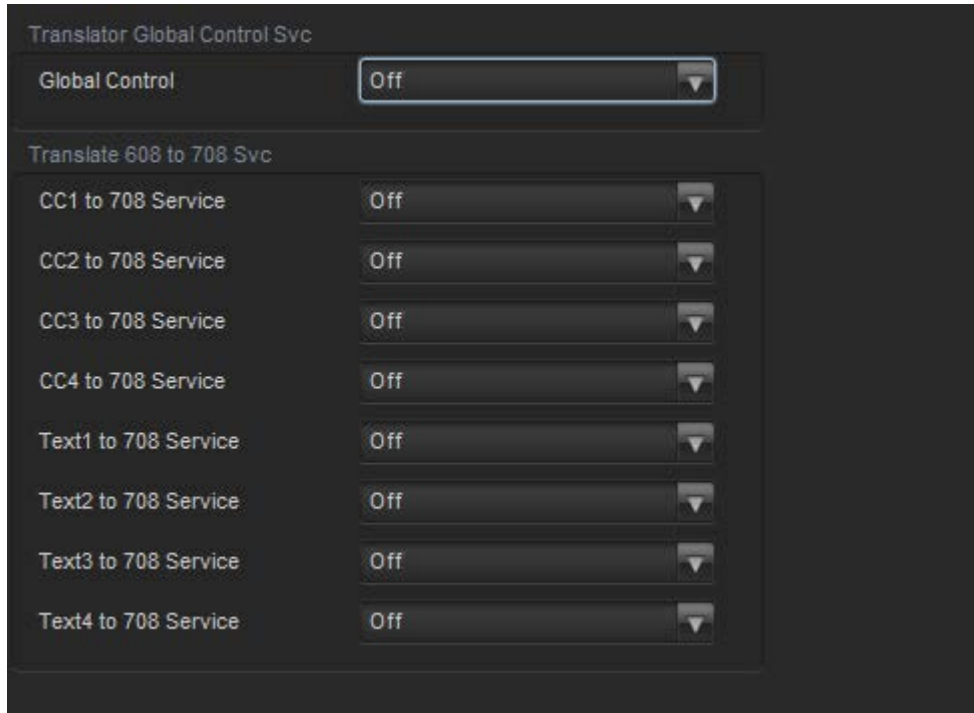

Figure 5-5: VistaLINK® Translator Tab

### 5.6.1. Translator Global Control Svc

**Global Control:** Allows the user to entirely turn on or off the 608-to-708 caption translator without changing the settings for each individual service. This allows the translator to be disabled in order to preserve existing upstream CEA-708 captions.

### 5.6.2. Translate 608 to 708 Svc

This feature allows the user to select the CEA-608 service (CC1, CC2, CC3, CC4, T1, T2, T3, and T4) to be translated to the CEA-708 services (1 through 16).



**Do not map more than one CEA-608 service to any CEA-708 service at the same time.**



**For second-language captions (e.g. Spanish or French), source material may have the second language encoded on CC2 or CC3.**

## 5.7. OSD / MONITORING

The *OSD* menu allows the user to configure the **On Screen Display** (OSD) and closed caption decoders for the 7825CCE-3G.

The 7825CCE-3G is capable of displaying the following information: CEA-608 captions, and CEA-708 captions.

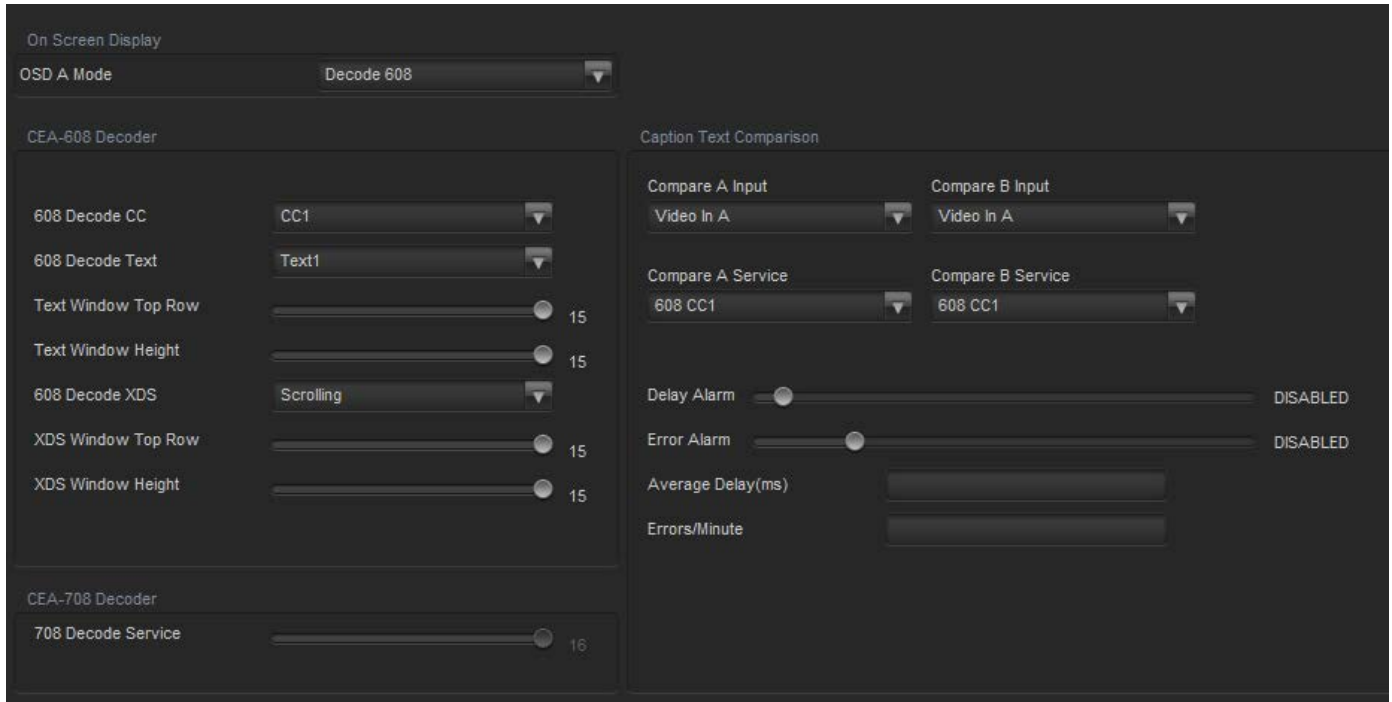

Figure 5-6: VistaLINK® OSD Tab

### 5.7.1. OSD A Mode

The OSD will appear on the A Monitoring Output BNC. The user can set the **OSD A Mode** to *Decode 608*, or *Decode 708*. The user can also choose to disable the OSD. Please note that **OSD A** will not function if the video passing through path A is “3G Level-B.”

The **Decode 608** option decodes CEA-608 captions present on both SD-SDI video and HD-SDI video. The **Decode 708** option decodes CEA-708 captions present on the HD-SDI video. The captions will appear as they are encoded on the output video of the 7825CCE-3G. The **Status/Faults** option displays all status information and fault information the 7825CCE-3G experiences. (Please see note below).



Please note that the **Status/Faults** mode is currently not implemented. If selected, the OSD will not display any text.

### 5.7.2. 708 Decode Service

This slider control allows the user to set the CEA-708 service (1 through 16) to decode when the OSD is configured as a CEA-708 caption decoder in OSD A Mode.

5.7.2.1. CEA-708 Decoder Specifications and Limitations

<b>Characters</b>	<ul style="list-style-type: none"> <li>• Supports parsing the entire code space as specified in section 7 of the standard, but due to font limitations, the glyphs for the G0 and G1 code spaces are not complete.</li> </ul>
<b>Windows</b>	<ul style="list-style-type: none"> <li>• Support for the full eight windows.</li> <li>• Anchor points and relative positioning are supported.</li> </ul>
<b>Window Attributes</b>	<ul style="list-style-type: none"> <li>• No window priorities.</li> <li>• No overlapping windows.</li> <li>• Only LEFT justification is supported.</li> <li>• Only LEFT_TO_RIGHT print direction.</li> <li>• TOP_TO_BOTTOM and BOTTOM_TO_TOP scroll direction.</li> <li>• No word-wrapping support.</li> <li>• No display effects.</li> <li>• No support for fill colour and opacity. (Solid black background only.)</li> <li>• No borders.</li> </ul>
<b>Pen Attributes</b>	<ul style="list-style-type: none"> <li>• Only STANDARD pen size is supported.</li> <li>• Only DEFAULT font style is supported.</li> <li>• No text tag support.</li> <li>• No offset (super-, and sub-script) support.</li> <li>• Italics are supported.</li> <li>• Underline is supported.</li> <li>• No edge type support.</li> </ul>
<b>Pen Colours</b>	<ul style="list-style-type: none"> <li>• No support for foreground and background colours or opacity. White text only.</li> </ul>

Table 5-1: 7825CCE-3G CEA-708 Decoder Specifications and Limitations

5.7.3. 608 Decode CC

The **608 Decode CC** parameter allows the user to select the caption channel the decoder will display on the OSD. The user can select caption channels 1 through 4. The caption channel can also be turned off.

5.7.4. 608 Decode Text

This parameter allows the user to select the Text channel the decoder will display on the OSD. The user can select text channels 1 through 4. The Text channel parameter can also be turned off.

5.7.5. Text Window Top Row

The **Text Window Top Row** parameter sets the window placement of the text box. Rows 1 through 15 can be selected. Row 1 is at the top of the screen and row 15 is at the bottom.



#### **5.7.6. Text Window Height**

The **Text Window Height** parameter sets the window size of the text box. Text box height 2 through 15 can be selected. Selection 2 will provide a 2 row high Text Box. Selection 15 will provide a text box that is 15 rows high.

#### **5.7.7. 608 Decode XDS**

The **608 Decode XDS** parameter selects the format that the XDS information will be displayed on. Three selections are available; *Scrolling*, *Fixed Position*, and *Off*. The *Scrolling* display will scroll the XDS information from top down. XDS packet types that are not recognized by the decoder will be shown as hexadecimal values. *Fixed Position* will display XDS packet data of the most common types at fixed locations within the XDS window. Unrecognized packet types will not be shown in this mode. The *Off* setting will remove the XDS window from on-screen.

#### **5.7.8. XDS Window Top Row**

The **XDS Window Top Row** parameter sets the window placement of the XDS display box. Rows 1 through 15 can be selected. Row 1 is at the top of the screen and row 15 is at the bottom.

#### **5.7.9. XDS Window Height**

The **XDS Window Height** parameter sets the window height of the XDS display box. XDS box height 2 through 15 can be selected. Selection 2 will provide a 2 row high Text Box. Selection 15 will provide an XDS display box that is 15 rows high.

#### **5.7.10. Caption Text Comparison**

The 7825CCE-3G is able to compare the text of the output captions on two services to determine the relative delay and show any difference. The two caption services may be on the same video path or on different video paths. Only the plain text is compared, not non-printing control codes which may affect the position, colour, italics or other attributes of the captions.

##### **5.7.10.1. Compare A/B Input**

Select the video path for caption text comparison.

##### **5.7.10.2. Compare A/B Service**

Select the caption services for comparison. Since only the plain text is being compared, not non-printing control codes, both CEA-608 and CEA-708 captions may be compared with each other.

##### **5.7.10.3. Delay Alarm**

This control enables and sets the threshold for the Delay Alarm. The Delay Alarm may be configured to activate a GPO and/or send an SNMP fault trap.

##### **5.7.10.4. Error Alarm**

This control enables and sets the threshold for the Error Alarm. The Error Alarm may be configured to activate a GPO and/or send an SNMP fault trap.

#### **5.7.10.5. Average Delay**

This read-only display shows the average delay between the two caption services being compared. If the value is negative, this indicates that the B service is ahead of the A service.

#### **5.7.10.6. Errors/Minute**

This read-only display shows average errors per minute. It is considered an “error” when a text appears on one of the comparison sources but not on the other.

## 5.8. COMM PORTS

The *COMM Ports* menu allows the user to configure the input/output settings of Ports A through D. Ports A, B, and C are RS232/422 ports, and Port D is a modem port.

The screenshot displays the 'COMM Ports Tab' configuration interface. It features a 'Super Port Select' dropdown set to 'None'. Below are four main sections for Port A, Port B, Port C, and Modem D. Each section contains a 'Setup' area with dropdown menus for Mode (Control-A), Baud (1200), Comms (8-none-1), Enable (Port Disabled), and Inactivity Reset (Disabled). A 'Monitor' field is provided for each. To the right of each setup area is a 'Permissions' section with checkboxes for CC1-CC4, Text1-Text4, and XDS. Below the permissions are 16 checkboxes labeled 'Service 1 Permission' through 'Service 16 Permission'. At the bottom, the 'Text Out Service' section includes dropdowns for Port A (CC1), Port B (CC1), Port C (CC1), and IpUDP (CC1). The 'Text Out Udp' section includes fields for Text Out Addr, Text Out Port, and a Text Out Enable dropdown set to 'Disable'.

Figure 5-7: VistaLINK® COMM Ports Tab

**5.8.1. Super Port Select**

The **Super Port** control is currently not available for the 7825CCE-3G.

**5.8.2. Port x Setup (x= A, B, C, D)**

**Port x Setup** allows the user to set the mode, baud, and communication separately for each port.

**5.8.2.1. Port x Mode**

The following is a list of the available:

PORT	Port A	Port B	Port C	Port D
<b>OUTPUT</b>	<ul style="list-style-type: none"> <li>▪ <b>Control A</b></li> <li>▪ Echo Port B</li> <li>▪ Echo Port C</li> <li>▪ Echo Port D</li> <li>▪ Rx in 608</li> <li>▪ Tx out 608</li> <li>▪ Rx in CDP</li> <li>▪ Tx out CDP</li> <li>▪ Link T Client</li> <li>▪ Echo Port E</li> <li>▪ Echo Port F</li> <li>▪ Echo Port G</li> <li>▪ ASCII Out</li> </ul>	<ul style="list-style-type: none"> <li>▪ <b>Control A</b></li> <li>▪ SMPTE -333M Out</li> <li>▪ G. Alliance Out</li> <li>▪ Echo Port A</li> <li>▪ Echo Port C</li> <li>▪ Echo Port D</li> <li>▪ Rx in 608</li> <li>▪ Tx out 608</li> <li>▪ Rx in CDP</li> <li>▪ Tx out CDP</li> <li>▪ Link T Client</li> <li>▪ Echo Port E</li> <li>▪ Echo Port F</li> <li>▪ Echo Port G</li> <li>▪ ASCII Out</li> </ul>	<ul style="list-style-type: none"> <li>▪ <b>Control A</b></li> <li>▪ Echo Port A</li> <li>▪ Echo Port B</li> <li>▪ Echo Port D</li> <li>▪ Rx in 608</li> <li>▪ Tx out 608</li> <li>▪ Rx in CDP</li> <li>▪ Tx out CDP</li> <li>▪ Link T Client</li> <li>▪ Echo Port E</li> <li>▪ Echo Port F</li> <li>▪ Echo Port G</li> <li>▪ ASCII Out</li> </ul>	<ul style="list-style-type: none"> <li>▪ <b>Control A</b></li> <li>▪ Link to Telnet Client</li> </ul>

**Table 5-2: Output Options**



**Only Port B supports SMPTE 333M and Grand Alliance communication protocols.**

**5.8.2.2. Port x Baud**

The **Port x Baud** option sets the baud rate of the selected port. Baud rates for all protocols have been pre-programmed. Always check to make sure the desired baud rate is selected when a different protocol is selected. The user may change the baud rates if desired.

The 7825CCE-3G can operate in the following baud rates on Port A through Port C: **1200**, 2400, 9600, 14400, 19200, 38400, 57600.

Baud Rate on Modem Port D: 1200, **2400**, 9600, Auto (up to 14400).

### 5.8.2.3. Port x Comms

**Port x Comms** configures the parity error setting of each port. The default setting for Control-A protocol is 7-Odd-1. Other protocols require 8 data bits, No parity, and 1 stop bit. The ports can be configured for the following settings:

- 8-None-1
- 7-Even-1
- 7-Odd-1

### 5.8.2.4. Port x Enable

The Port x Enable control allows the user to individually enable or disable the communication ports. A port may be explicitly enabled or disabled, enabled based on the state of a GPI pin, or enabled only when the modem or telnet are not in use.

PORT	Port A	Port B	Port C	Port D	Port E - G
<b>OUTPUT</b>	<ul style="list-style-type: none"> <li>▪ <b>Port Disabled</b></li> <li>▪ Port Enabled</li> <li>▪ GPI-A Enables</li> <li>▪ GPI-B Enables</li> <li>▪ GPI-C Enables</li> <li>▪ GPI-D Enables</li> <li>▪ GPI-E Enables</li> <li>▪ GPI-F Enables</li> <li>▪ Modem Disables</li> <li>▪ Telnet Disables</li> <li>▪ Modem/Telnet Disables</li> </ul>	<ul style="list-style-type: none"> <li>▪ <b>Port Disabled</b></li> <li>▪ Port Enabled</li> <li>▪ GPI-A Enables</li> <li>▪ GPI-B Enables</li> <li>▪ GPI-C Enables</li> <li>▪ GPI-D Enables</li> <li>▪ GPI-E Enables</li> <li>▪ GPI-F Enables</li> <li>▪ Modem Disables</li> <li>▪ Telnet Disables</li> <li>▪ Modem/Telnet Disables</li> </ul>	<ul style="list-style-type: none"> <li>▪ <b>Port Disabled</b></li> <li>▪ Port Enabled</li> <li>▪ GPI-A Enables</li> <li>▪ GPI-B Enables</li> <li>▪ GPI-C Enables</li> <li>▪ GPI-D Enables</li> <li>▪ GPI-E Enables</li> <li>▪ GPI-F Enables</li> <li>▪ Modem Disables</li> <li>▪ Telnet Disables</li> <li>▪ Modem/Telnet Disables</li> </ul>	<ul style="list-style-type: none"> <li>▪ <b>Port Disabled</b></li> <li>▪ Port Enabled</li> <li>▪ GPI-A Enables</li> <li>▪ GPI-B Enables</li> <li>▪ GPI-C Enables</li> <li>▪ GPI-D Enables</li> <li>▪ GPI-E Enables</li> <li>▪ GPI-F Enables</li> <li>▪ Telnet Disables</li> </ul>	<ul style="list-style-type: none"> <li>▪ <b>Port Disabled</b></li> <li>▪ Port Enabled</li> <li>▪ GPI-A Enables</li> <li>▪ GPI-B Enables</li> <li>▪ GPI-C Enables</li> <li>▪ GPI-D Enables</li> <li>▪ GPI-E Enables</li> <li>▪ GPI-F Enables</li> <li>▪ Modem Disables</li> </ul>

**Table 5-3: Port Enable Options**

The "Modem Disables", "Telnet Disables" and "Modem/Telnet Disables" selections will cause the indicated port to become disabled when the modem (Port D) or telnet session (Ports E-G) are in use. This would typically be selected for a port that is connected to a teleprompter, so that a remote real-time captioner can over-ride the teleprompter to caption live events.

The affected communications port will not be disabled until the modem or telnet port receives a character in the range ^A through ^G, indicating the start of a Control-A protocol command. This allows a live captioner to connect ahead of their allotted start time without disrupting teleprompter captioning in progress.

### 5.8.3. Port x Inactivity Reset

Each port has an inactivity timer that will force it to reset automatically if no data is received before the timeout period expires. The timeout period is adjustable from 1 to 31 minutes. Operators should set this to be longer than the longest expected time that a remote captioner may sit without sending any captions to the 7825CCE-3G, such as through a commercial segment.

When this feature is enabled no data received before the timeout will cause the port reset as if the ^F^F command was issued. The Control-A interface will be forced to Command state and will relinquish control of any assigned caption services. It will also end any special settings, such as blocking of upstream captions that were issued from the respective port. This timeout will NOT cause a modem or telnet session to be closed.

#### **5.8.4. Port x Permission (x= A, B, C, D)**

The **Port x Permission** option allows the user to enable/disable CEA-608 and CEA-708 services on each of the ports. CEA-608 services include *CC1*, *CC2*, *CC3*, *CC4*, *T1*, *T2*, *T3*, *T4*, and *XDS*. CEA-708 includes services *1* through *16*. Each of these services can be enabled or disabled separately. All services are enabled by default.

#### **5.8.5. Text Out Service**

For Ports A, B and C, this control allows the user to set the desired caption service to use when the corresponding Port Mode is set to *ASCII Text Out*. The UDP Text Out Service control selects the desired caption service to use in conjunction with the UDP ASCII Text Streaming feature described in section 5.8.6. The specified caption service will be output as plain ASCII text with CEA-608 control codes removed.

#### **5.8.6. UDP ASCII Text Streaming**

The UDP Text Streaming feature allows the user to select a CEA-608 service to convert to plain ASCII text and stream out on the network via UDP IP packets. The control for specifying the caption service is described in section 5.8.5. Other controls to configure this feature are described in this section.

##### **5.8.6.1. Client IP Address**

This control allows the user to set the destination IP address for the stream of ASCII Text UDP packets.

##### **5.8.6.2. Text Out Port**

This control allows the user to set the destination IP port number for the stream of ASCII Text UDP packets. The acceptable range is 1025 to 65535.

##### **5.8.6.3. Stream Enable**

This checkbox control enables output of ASCII Text UDP packets to the destination IP Address.

## 5.9. TELNET PORTS

The *Telnet Ports* menu allows the user to configure the input/output settings of Telnet.

The screenshot displays the configuration interface for Telnet ports, organized into several sections:

- Telnet Login:** Includes 'Telnet Login Enable' (set to Disabled), 'Telnet Login' and 'Telnet Password' fields, and a 'Disconnect Timeout' slider set to 31 Minutes.
- Telnet Client:** Includes 'Telnet Server Address', 'Telnet Server TCP Port' (set to Port 23), 'Telnet Client Login Enable' (set to Disabled), 'Telnet Client User Name', 'Telnet Client Password', and 'Telnet Client Connection' buttons (Connect, Disconnect). A 'Telnet Client Status' field is also present.
- Telnet E Setup:** Includes 'Mode' (Control-A), 'Enable' (Port Disabled), 'Inactivity Reset' (Disabled), 'TCP Port Control' (Port 23), 'Monitor', and 'Status' fields.
- Telnet E 608 Permission:** A grid of checkboxes for permissions: CC1-CC4, Text1-Text4, and XDS.
- Telnet E 708 Permission:** A grid of checkboxes for Service 1 through Service 16 permissions.
- Telnet F Setup:** Similar to Telnet E Setup, with 'Mode' (Control-A), 'Enable' (Port Disabled), 'Inactivity Reset' (Disabled), 'TCP Port Control' (Port 23), 'Monitor', and 'Status' fields.
- Telnet F 608 Permission:** Similar to Telnet E 608 Permission, with checkboxes for CC1-CC4, Text1-Text4, and XDS.
- Telnet F 708 Permission:** Similar to Telnet E 708 Permission, with checkboxes for Service 1 through Service 16.
- Telnet G Setup:** Similar to Telnet E Setup, with 'Mode' (Control-A), 'Enable' (Port Disabled), 'Inactivity Reset' (Disabled), 'TCP Port Control' (Port 23), 'Monitor', and 'Status' fields.
- Telnet G 608 Permission:** Similar to Telnet E 608 Permission, with checkboxes for CC1-CC4, Text1-Text4, and XDS.
- Telnet G 708 Permission:** Similar to Telnet E 708 Permission, with checkboxes for Service 1 through Service 16.

Figure 5-8: VistaLINK® Telnet Ports Tab

### **5.9.1. Telnet Login**

**Telnet Login Enable:** This control allows the user to enable or disable the Telnet Login. If Telnet Login is disabled, the Telnet Client will be immediately presented with a Control-A prompt upon connection.

The **Telnet Login** and **Password** fields allow the user to enter username and password information.

### **5.9.2. Disconnect Timeout**

This is a global control which affects all telnet ports (E, F, G). When enabled, this control sets the timeout duration that will cause a telnet session to disconnect if no data is received before the timeout period expires. This allows the port to disconnect automatically if the connection is lost. The timeout period is adjustable for 1 to 31 minutes.

### **5.9.3. Telnet x Setup**

#### **5.9.3.1. Telnet x Mode**

This control will only allow the user to set the Telnet mode to Control-A for each of the available Telnet ports.

#### **5.9.3.2. Telnet x Enable**

The Telnet x Enable control allows the user to individually enable or disable the telnet ports. A port may be explicitly enabled or disabled, enabled based on the state of a GPI pin, or enabled only when the telnet is not in use. See Table 5-3 for available options.

The "Modem Disables" selection will cause the port to become disabled when the modem session (Port D) is in use. This would typically be selected for a port that is connected to a teleprompter, so that a remote real-time captioner can over-ride the teleprompter to caption live events.

#### **5.9.3.3. Telnet x Inactivity Reset**

Each port has an inactivity timer that will force it to reset automatically if no data is received before the timeout period expires. The timeout period is adjustable from 1 to 31 minutes. Operators should set this to be longer than the longest expected time that a remote captioner may sit without sending any captions to the 7825CCE-3G, such as through a commercial segment.

When this feature is enabled no data received before the timeout will cause the port reset as if the ^F^F command was issued. The Control-A interface will be forced to Command state and will relinquish control of any assigned caption services. It will also end any special settings, such as blocking of upstream captions that were issued from the respective port. This timeout will NOT cause a modem or telnet session to be closed.



#### 5.9.3.4. TCP Port Control

The available options for port control are Port 23 (the standard telnet port), Port 24, Port 26 and Any. By default, all three telnet servers are listening on IP port 23. The first captioner to connect would be on Port E, the second on Port F, and potentially a third on Port G.

Using these controls the user can force any telnet server to instead listen on non-standard IP ports 24 or 26. If the captioner's software can be configured to connect to a non-standard IP port for telnet, that allows the user to force each of the English and Spanish captioners onto specific Com Ports, Port E and Port F for example. Then setup the port permissions to disable Port E from captioning on all except CC1, and disable Port F from captioning on all except CC2/CC3 to guarantee that the captioners don't interfere with each other.

If the above scheme is implemented, the user may also wish to set Com Port G to listen on "Any" IP port (23, 24 or 26). That way, if either captioner has an unintentional disconnect and their regular telnet Port (E or F) is left hanging until the disconnect timeout resets it, they can reconnect immediately (to Port G) and resume captioning.

#### 5.9.4. Telnet x Permission

The **Telnet x Permission** option allows the user to enable/disable CEA-608 and CEA-708 services for each Telnet port. CEA-608 services include *CC1, CC2, CC3, CC4, T1, T2, T3, T4, and XDS*. CEA-708 includes services *1 through 16*. Each of these services can be enabled or disabled separately. All services are enabled by default.

### 5.10. TELNET CLIENT

The Telnet Client function allows the 7825CCE-3G to connect to an available telnet port of another 7825CCE-3G or other telnet server on the network. Once connected, data received on the specified communications port on this 7825CCE-3G will be echoed out to the remote telnet server. The primary purpose of this feature is to allow the 7825CCE-3G to act as a serial/modem-to-telnet bridge to connect to a caption encoder which only has telnet ports for caption data input.

#### 5.10.1. Telnet Client

**Telnet Server Address:** Enables the user to enter a Telnet server IP address.

**Telnet Server TCP Port:** Enables the user select a Telnet server TCP port number. Options include: *Port 23, Port 24, and Port 26*.

**Telnet Client Login Enable:** Allows the user enable or disable the Telnet Client.

**Telnet Client User Name:** Enables the user to enter a user name.

**Telnet Client Password:** Enables the user to enter a password.

**Telnet Client Connection:** Enables the user to connect or disconnect the Telnet Client.

**Telnet Client Status:** Displays whether Telnet Client is connected or disconnected.

### 5.11. GPI/O

The *GPI/O* menu, as illustrated in Figure 5-9, is used to define specific behaviour of the GPOs.

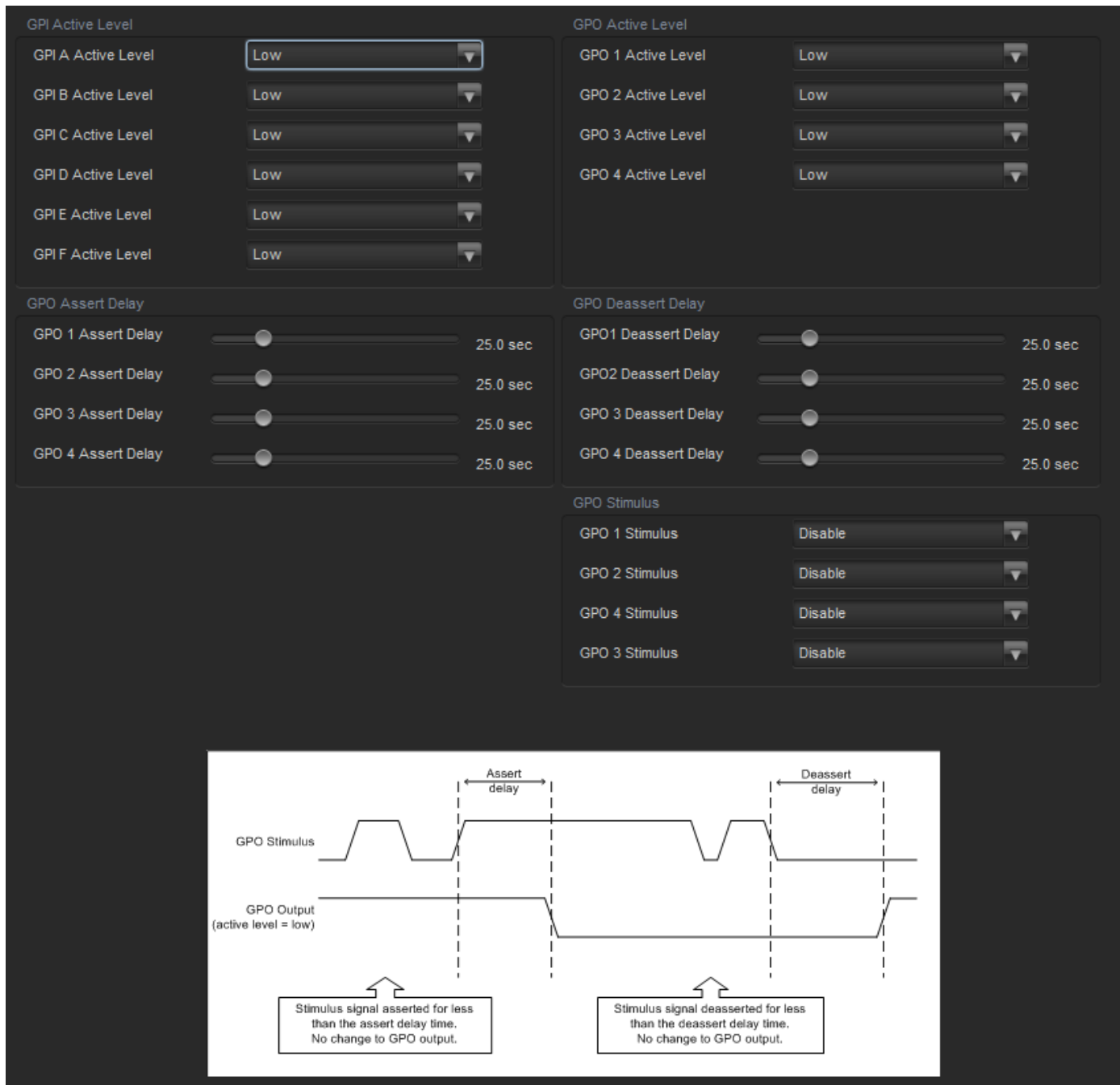

Figure 5-9: VistaLINK® GPI/O Tab

#### 5.11.1. GPI A to F Active Level

GPI's A through F can be configured using this menu. The active level can be set to *High* or *Low*. The default setting is *Low*.

### 5.11.2. GPO 1 to 4 Active Level

The GPO active level can be defined based on the requirements of the application. The active level can be set to *High* or *Low*. The default setting is *Low*.

### 5.11.3. GPO 1 to 4 Assert Delay

The GPO assertion can be delayed by a set amount of time to provide hysteresis. If the Assert Delay is not zero, the stimulus that controls the GPO must remain in the active state for the specified amount of time before the GPO will become asserted. The **GPO x Assert Delay** has a range of 0 to 127.5s, which can be adjusted in increments of 0.5s. The default setting is 0 sec. Figure 5-10 illustrates the Assert Delay.

### 5.11.4. GPO 1 to 4 De-assert Delay

The GPO de-assertion can be delayed by a set amount of time. If the De-assert Delay is not zero, the stimulus that controls the GPO must become inactive for the specified amount of time before the GPO will become de-asserted. The **GPO x Assert Delay** has a range of 0 to 127.5s, which can be adjusted in increments of 0.5s. The default setting is 0 sec. Figure 5-10 illustrates the De-assert Delay.

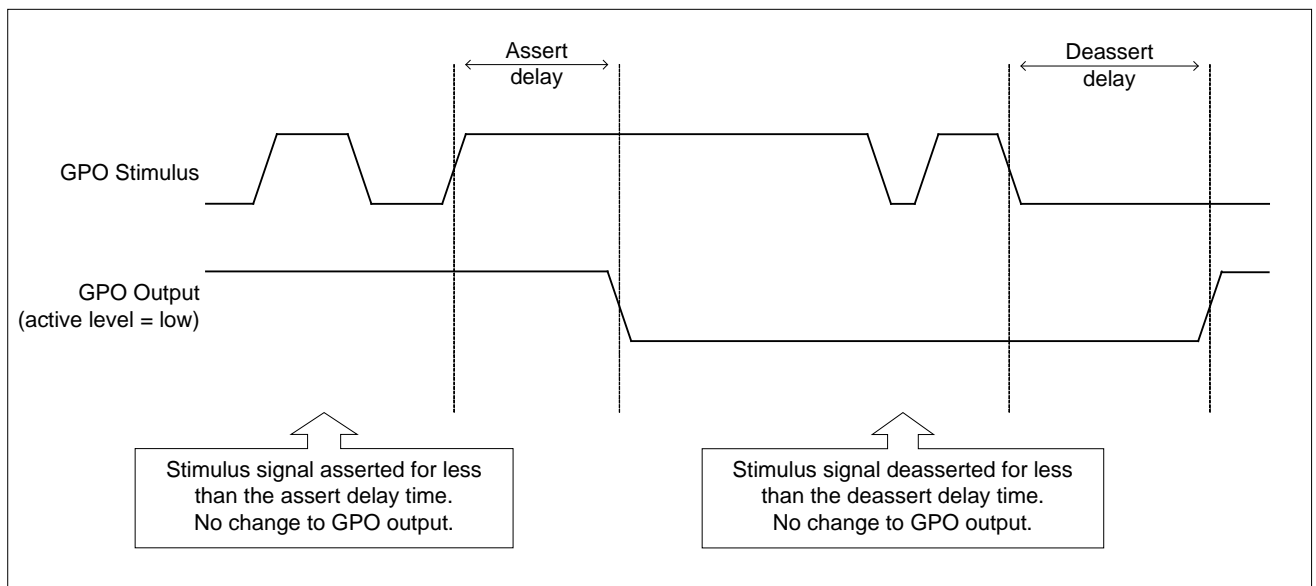

Figure 5-10: GPIO Functionality

#### 5.11.5. GPO 1 to 4 Stimulus

There are four GPO pins available on the rear panel. The function of each GPO pin is configurable. This control defines what stimulus signal will be used to assert the GPO. Possible stimuli include:

- Disabled
- ½ Hz Squarewave Out (useful for problem diagnosis)
- A Video In Present
- B Video In Present
- Port (A to D) Receive Data
- Telnet Receive Data
- Fault Tally
- CC1 to CC4 Data In
- T1 to T4 Data In
- XDS Data In
- 708 Data In (any service)
- Modem D Online
- Input A 608 Field 1 Waveform
- Input A 608 Field 2 Waveform
- Input A VANC CDP In
- Input B VANC CDP In
- Input B 608 Field 1 Wfm
- Input B 608 Field 2 Wfm
- Compare Delay Alarm
- Compare Error Alarm
- CC1 to CC4 Inactive Alarm
- T1 to T4 Inactive Alarm
- XDS Inactive Alarm
- Svc 1 to Svc 6 Inactive Alarm

The default setting is Disabled.

## 5.12. AFD CONTROL

The *AFD* menu, as illustrated in Figure 5-11, enables the user to configure the settings for Active Format Description VANC packet.



The controls in this tab configure what the payload of the AFD packet will be. They do not alter the picture in any way.

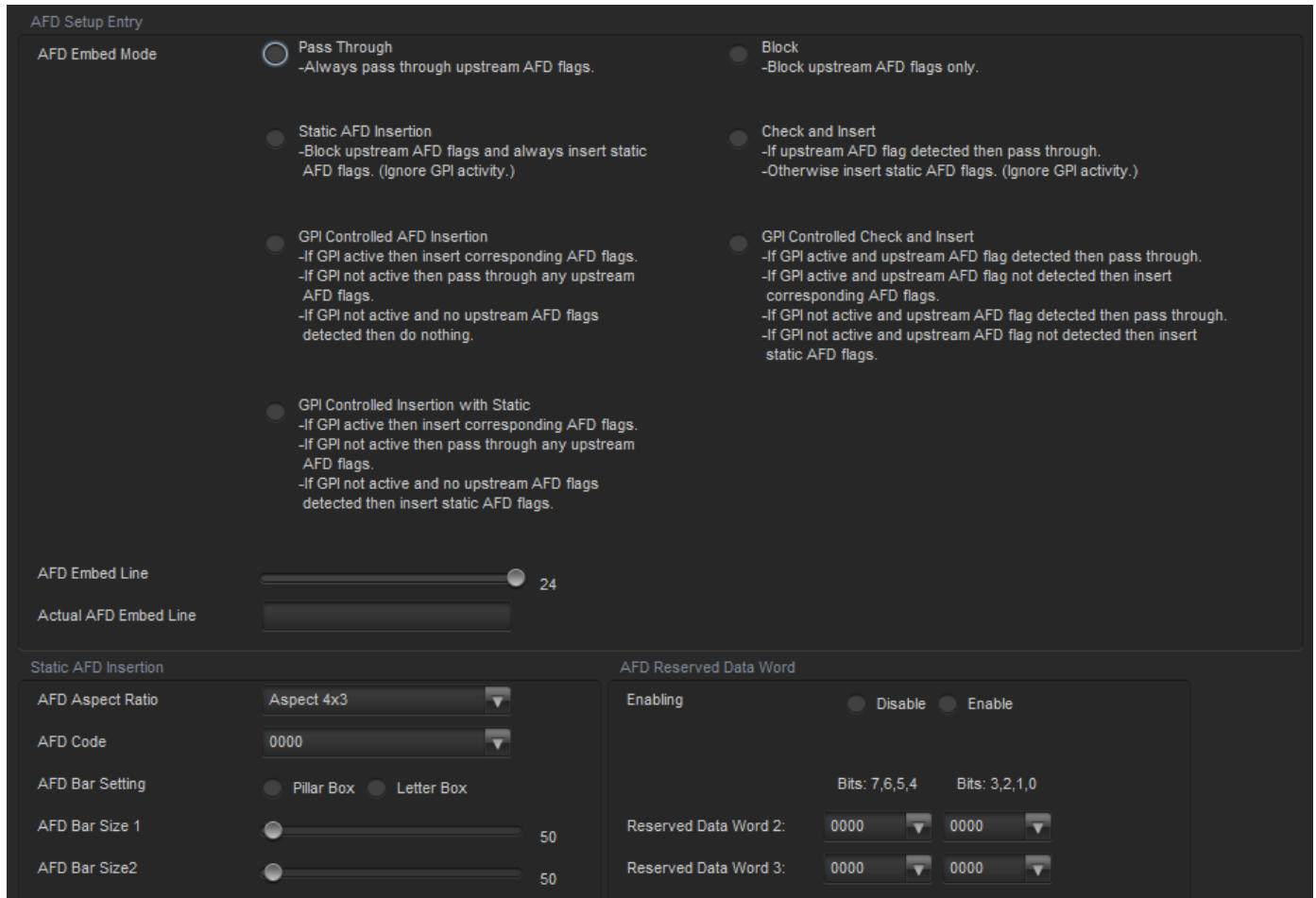

Figure 5-11: VistaLINK® AFD Control Tab

### 5.12.1. AFD Embed Mode

This parameter sets the AFD packet embed mode.

Selecting *Passthru* will pass through existing AFD packets from upstream. Selecting *Block* will erase any incoming AFD packets. Selecting *Insert* will allow static AFD insertion while blocking incoming AFD. Note that this control will have no effect if the VANC Keyer is turned off.

### 5.12.2. AFD Embed Line

This parameter sets which line AFD packets will be embedded on. The user can choose between 7 and 24 in increments of one.

### 5.12.3. AFD Code

This parameter sets the AFD code that is inserted. These codes are used in conjunction with the AR parameter. Refer to Figure 5-12 for a visualization of each code.

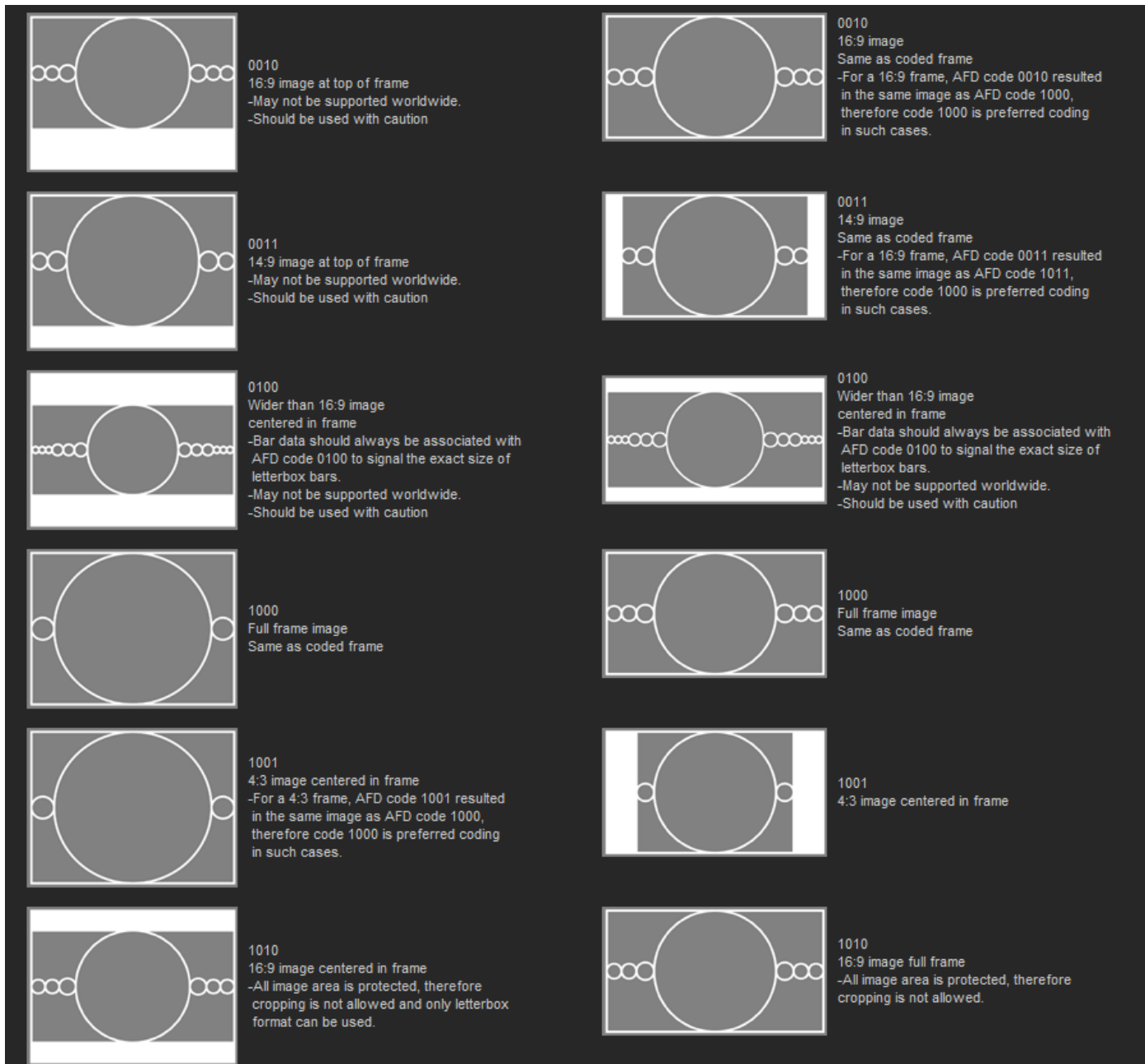

**Figure 5-12: AFD Control Codes**

#### **5.12.4. AFD Aspect Ratio**

This parameter sets whether the original frame is 4:3 or 16:9 aspect ratio coded. A selection of 4x3 will choose AFD codes from the 4:3 selections. A selection of 16x9 will choose AFD codes from the 16:9 selections.

#### **5.12.5. AFD Bar Setting**

This parameter sets the type of bars that are on the picture when using bar data. Selecting the *PillarBox* option will be valid for video that has bars on the sides (pillarboxed). Selecting the *LetterBox* option will be valid for video that has bars on the top and bottom (letterboxed).

### 5.12.6. AFD Bar Size 1

This parameter sets the size of the first bar, as selected under **AFD Bar Setting**. The values available in this field (0 to 1919) will depend on the input video format. The settings for **AFD Bar Size 2** are identical.

### 5.12.7. AFD Reserved Data Word Enabling

This parameter enables or disables AFD Reserved Data Word override. The default value is **Disabled**.

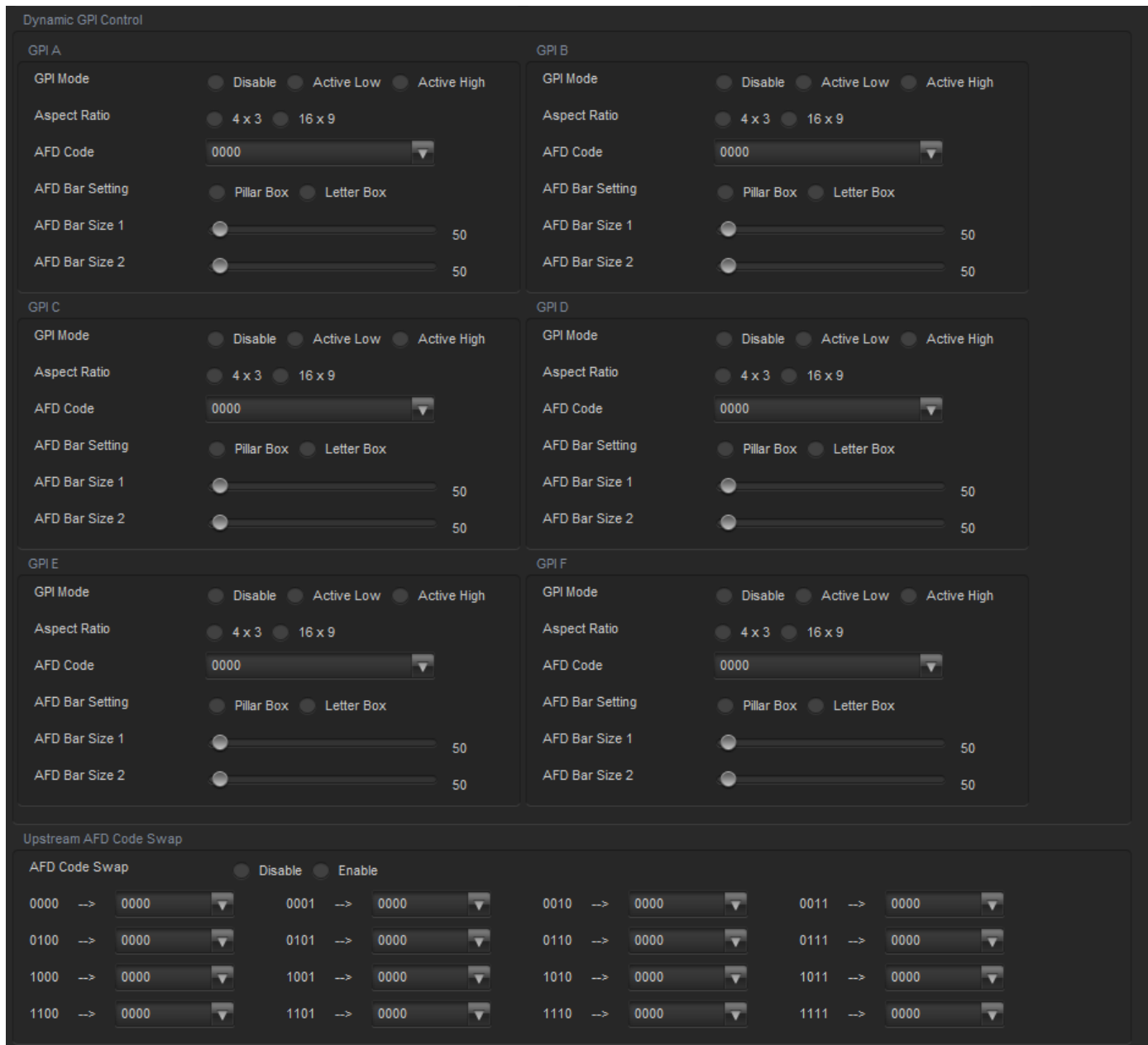

Figure 5-13: VistaLINK® AFD Control Tab continued



**5.12.8. GPI x Mode (x=A-F)**

The **GPI x Mode** control is used to set the GPI mode for AFD insert. The values are disable, Active Low or Active High.

**5.12.9. GPI x Aspect Ratio (x=A-F)**

The **GPI x Mode** control is used to set the GPI mode for AFD insert. The values are disable, Active Low or Active High.

**5.12.10. GPI x AFD Code (x=A-F)**

This parameter sets the AFD code that is inserted. These codes are used in conjunction with the AR parameter. Refer to Figure 5-12 for a visualization of each code. The value range is 0 to 15, where 1,5,6,7 and 12 are not valid code values.

**5.12.11. GPI x AFD Bar Setting (x=A-F)**

This parameter sets the type of bars that are on the picture when using bar data. Selecting the *PillarBox* option will be valid for video that has bars on the sides (pillarboxed). Selecting the *LetterBox* option will be valid for video that has bars on the top and bottom (letterboxed).

**5.12.12. GPI x AFD Bar Size 1 (x=A-F)**

This parameter sets the size of the first bar, as selected under **AFD Bar Setting**. The values available in this field (0 to 1919) will depend on the input video format. The settings for **AFD Bar Size 2** are identical.

### 5.13. TIME

The 7825CCE-3G has a built-in Real-Time Clock (RTC) with battery backup for maintaining the current time and date. It can also retrieve the time and date from Network Time Protocol (NTP) or from video timecode. One of these three sources may be selected as the “Effective Time”, which is used for certain functions described elsewhere.

Time from all sources is converted to Coordinated Universal Time (UTC) for processing within the 7825CCE-3G. UTC is an international time standard that defines a time that does not depend on where we are on Earth. UTC, Greenwich Mean Time (GMT), and Zulu Time (Z), are based at the prime meridian (0° longitude) of Earth and are used to avoid confusion of time zones.

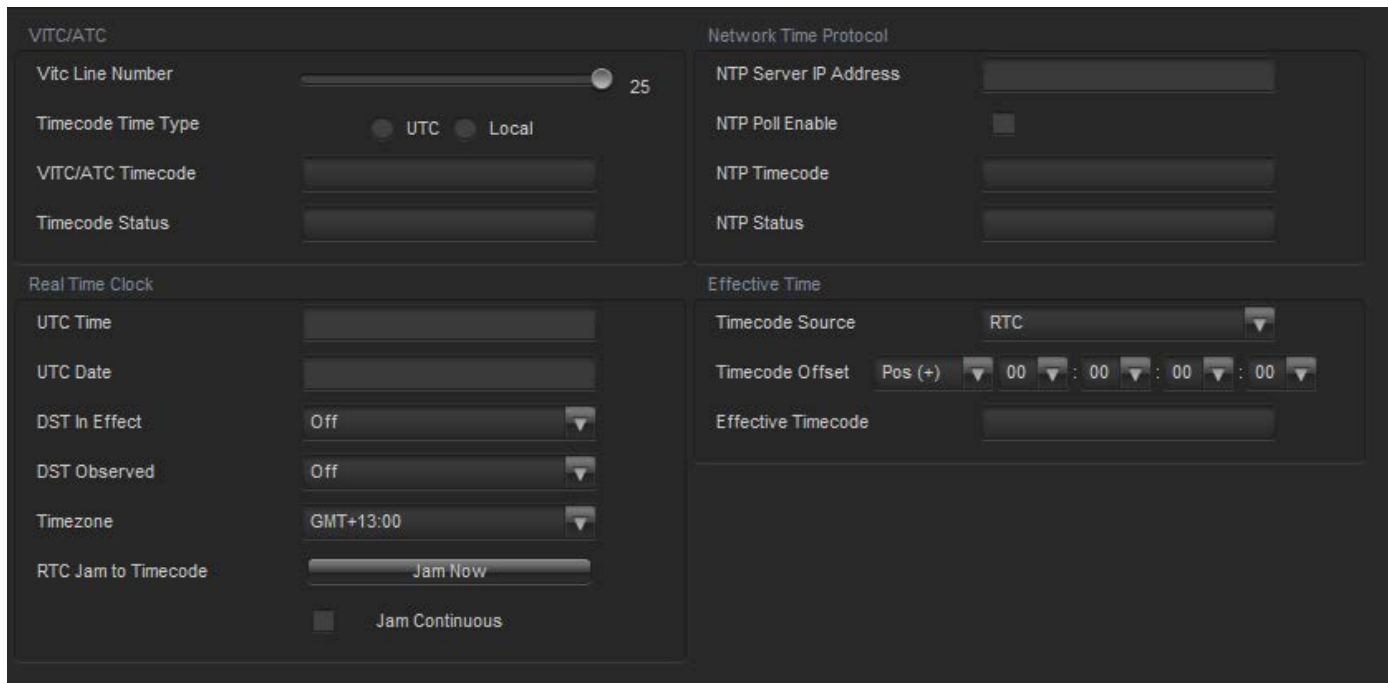

Figure 5-14: VistaLINK® Time Tab

#### 5.13.1. VITC/ATC

##### 5.13.1.1. VITC Line Number

The **VITC Line Number** control enables the user to set the line where VITC is to be read from. Only applicable when reading from SD-SDI video. The range is between line 10 to line 25.

##### 5.13.1.2. Timecode Time Type

The **Timecode Time Type** control enables the user to select whether the input timecode represents Coordinated Universal Time (UTC) or Local time.

##### 5.13.1.3. VITC/ATC Timecode

The **VITC/ATC Timecode** displays the detected timecode from incoming SDI ATC or VITC.

#### 5.13.1.4. Timecode Status

The **Timecode Status** displays the status of timecode from incoming SDI. (e.g. ATC-VITC LOCKED)

#### 5.13.2. Network Time Protocol

This section enables the user to configure parameters related to Network Time Protocol (NTP) as a time source for the 7825CCE-3G. NTP is always transmitted in UTC format.

##### 5.13.2.1. NTP Server IP Address

The **NTP Server IP Address** control enables the user to set the IP address of the NTP server from which the 7825CCE-3G will request the current time.

##### 5.13.2.2. NTP Poll Enable

The **NTP Poll Enable** allows the user to enable or disable polling of the NTP server.

##### 5.13.2.3. NTP Timecode

The **NTP Timecode** displays the time from the NTP server in hh:mm:ss format and date in yy/mm/dd format.

##### 5.13.2.4. NTP Status

The **NTP Status** displays the NTP status. Typical messages include: Not Polling, JAMMING TIME, Locked -- Time Sync, Timeout Waiting for Peer, Peer Stratum too High.

#### 5.13.3. Real Time Clock

##### 5.13.3.1. UTC Time

This menu item is used to display the current UTC time maintained by the Real Time Clock (RTC). The time displays are always shown in the 24-hour time format.

##### 5.13.3.2. UTC Date

This menu item is used to display the current UTC date, in yy:mm:dd format, maintained by the Real Time Clock (RTC).

##### 5.13.3.3. DST In Effect

This control is used to indicate whether Daylight Saving Time (DST) is currently in effect. The DST setting will be used to calculate the current local time, and to set the DST flag in XDS packets.

When set to *off*, Daylight Saving Time compensation will not be applied. When set to *on*, Daylight Saving Time compensation will be applied to the time.

#### **5.13.3.4. DST Observed**

The **DST Observed** control allows the user to specify whether Daylight Saving Time is observed in their locale. This is used to calculate the current local time, and to set the DSO flag in XDS packets. For regions that observe Daylight saving time, the DST Observed setting must be set to *On*, and for regions that do not observe Daylight saving time, the DST Observed setting must be set to *Off*.

#### **5.13.3.5. Timezone**

This option allows the user to set a time zone offset between the UTC time and the Local time. This time zone offset will be added to the UTC time along with the Daylight Saving time correction to obtain the Local time. Time zones are normally in one hour or 30 minute increments and can be + or – from UTC. (Time zones east of Greenwich are +, and time zones west of Greenwich are -).

#### **5.13.3.6. RTC Jam to Timecode**

This button sets the 7825CCE-3G to continuously jam its internal Real Time Clock time and date to the current “Effective Time”. The **Jam Now** button syncs the RTC to the Effective Time instantaneously but does not continuously lock the RTC to the Effective Time. Note that these controls have no effect if the RTC is selected as the time source for Effective Time.

#### **5.13.4. Effective Time**

**Effective Time** is the time that will be used by the card for the insertion of XDS Time-of-Day packets. If this module has the +CF option, this feature is also the time reference that will be used when inserting closed caption data from files from compact flash or generating closed caption capture files.

##### **5.13.4.1. Timecode Source**

This option allows the user to set the Timecode Source to be used for the Effective Time. The user can select either the VITC/ATC source, the Real Time Clock (RTC) source or the Network Time Protocol (NTP) source to use.

##### **5.13.4.2. Timecode Offset**

These controls allow the user to set the Timecode Offset to be used for the Effective Time. The user can set the offset to be ahead (+) or behind (-) and set the hours, minutes, seconds and frames to offset the time by.

##### **5.13.4.3. Effective Timecode**

This field will display the Timecode value of the video based off the values set above.

## 5.14. SYSTEM

The System tab (as shown in Figure 5-15) enables the user to define the system settings for the 7825CCE-3G module.

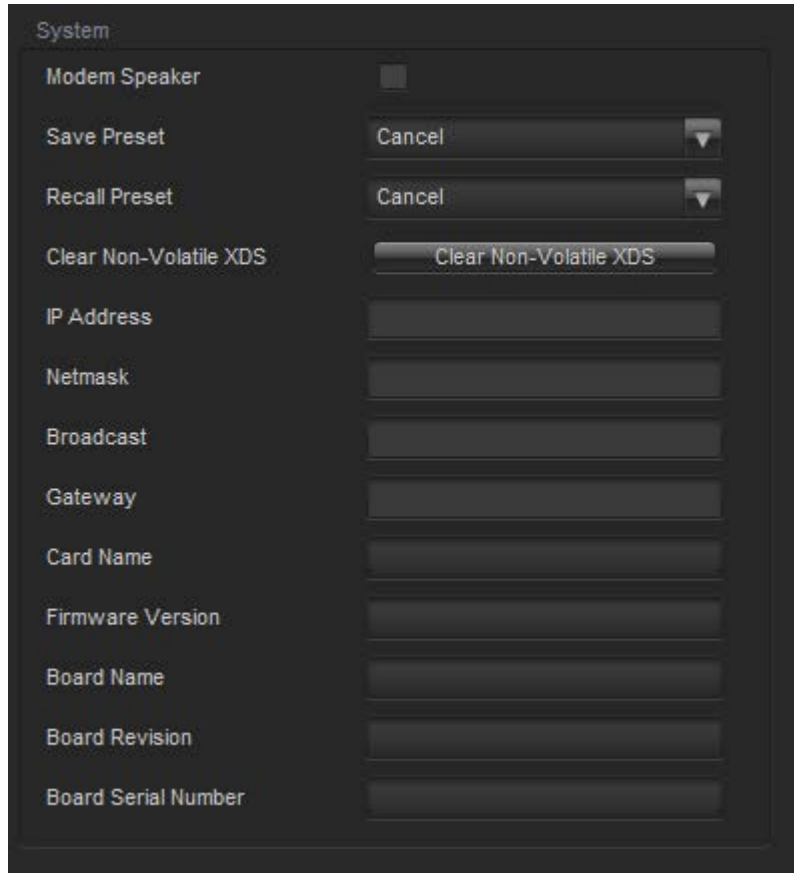

**Figure 5-15: VistaLINK® System Tab**

### 5.14.1. Modem Speaker

This option allows the user to enable or disable the **Modem Speaker**. When enabled, the modem speaker will be on while the modems are in the “handshake” state as a diagnostic aid to the operator.

### 5.14.2. Save Preset

This menu item is used to store the *System* settings to 1 of the 4 user presets.

### 5.14.3. Recall Preset

This menu item is used to recall 1 of the 4 user presets for the System settings.

### 5.14.4. Clear Non-Volatile XDS

Some types of XDS articles are stored in non-volatile memory, which is preserved through power loss. The **Clear Non-Volatile XDS** pushbutton control removes XDS articles from memory. See section 6.5.5 for more information on non-volatile XDS articles.

#### **5.14.5. IP Address**

This parameter defines the unique IP address used by the 7825CCE-3G within the network. 192.168.1.XXX is an example of an IP address defined within a private (internal) network. Take care not to define the same IP address for multiple devices that reside on the same network.

#### **5.14.6. Netmask**

This parameter defines the “subnet mask” of the network. Specifically, this parameter outlines all the IP addresses that are on the same subnet as the 7825CCE-3G.

#### **5.14.7. Broadcast**

This parameter defines the broadcast address used by the 7825CCE-3G. The broadcast address is an IP address that allows information to be sent to all machines on a given subnet rather than a specific machine.

#### **5.14.8. Gateway**

This parameter defines the IP address of the gateway or “router” that resides on the network. A gateway is used to connect 2 IP-based networks together. If data that is destined for the 7825CCE-3G resides on a different network, then the IP address of the gateway must be defined.



**To communicate beyond the private (internal) network and into the internet, all messages must be relayed via the gateway (firewall). As a result, the firewall must be configured separately by the end-user to facilitate communication. Consult your network administrator if establishing communication link beyond the private network.**

#### **5.14.9. Firmware Version**

This parameter provides the user with the Firmware version.

#### **5.14.10. Board Information**

These 3 separate fields display the board name, board revision number as well as the board serial number.

## 5.15. COMPACT FLASH

The screenshot displays the 'Compact Flash' configuration interface, divided into 'Data Capture' and 'Data Encode' sections.

**Data Capture Section:**

- CC Data Capturing:** Radio buttons for 'UpStream' and 'DownStream' (selected).
- CEA-608:** File Name: 'cap608', extension: '.608', 'Capture' button, checkboxes for 'Field 1' and 'Field 2' (both checked), and a 'Status' field.
- Procap:** File Name: 'cappro', extension: '.txt', 'Capture' button, 'Caption Service' dropdown set to 'CC 1', and a 'Status' field.
- CDP/CP2007 (Caption Distribution Packets):** File Name: 'capcdp', extension: '.cdp', 'Capture' button, and a 'Status' field.
- SCC (Scenarist Closed Captions):** File Name: 'capscs', extension: '.scc', 'Capture' button, 'Field' dropdown set to 'Field 1', and a 'Status' field.
- Port:** File Name: 'capprt', extension: '.prt', 'Capture' button, 'Comm Port' dropdown set to 'Port A', and a 'Status' field.

**Data Encode Section:**

- File Type Select:** Radio buttons for 'CEA-608' (selected), 'Procap', 'CDP', 'SCC', and 'Stop'.
- CEA-608 File:** File Name: 'cap608', extension: '.608', checkboxes for 'Field 1' and 'Field 2' (both checked), and a 'Status' field.
- Procap File:** File Name: 'cappro', extension: '.txt', and a 'Status' field.
- CDP File:** File Name: 'capcdp', extension: '.cdp', and a 'Status' field.
- SCC File:** File Name: 'capscs', extension: '.scc', 'Field' dropdown set to 'Field 1', and a 'Status' field.
- Effective Timecode:** Input field showing '00:29:33:20 01/01/18'.
- Status:** A large field displaying 'File interface 4 init'.

Figure 5-16: Compact Flash Tab

### 5.15.1. Data Capture

**CC Data Capturing:** This control allows the user to determine if the module will capture CC data that is observed at the input BNC (Upstream of Processing) or at the output BNC (Downstream of Process).

#### 5.15.1.1. CEA-608

**File Name:** This field allows the user to enter a name for the CEA-608 file.

**Capture:** This button will start/stop the capture of the caption service to the CEA-608 file

**Status:** This field displays the status of the CEA-608 file.

---

**Field:** This control allows the user to select which field(s) should be stored in the CEA-608 capture file.

#### 5.15.1.2. Procap

**File Name:** This field allows the user to enter a name for the Procap file.

**Capture:** This button will start/stop the capture of the caption service to the Procap file.

**Status:** This field displays the status of the Procap file.

**Caption Service:** This control allows the user to select which caption service to save to the Procap file.

#### 5.15.1.3. CDP/RP2007 (Caption Distribution Packets)

**File Name:** This field allows the user to enter a name for the CDP file.

**Capture:** This button will start/stop the capture of the caption service to the CDP file.

**Status:** This field displays the status of the CDP file.

#### 5.15.1.4. SCC (Scenarist Closed Captions)

**File Name:** This field allows the user to enter a name for the SCC file.

**Capture:** This button will start/stop the capture of the caption service to the SCC file.

**Status:** This field displays the status of the SCC file.

**Field:** This control allows the user to select whether Field 1 or Field 2 data is saved to the SCC file.

#### 5.15.1.5. Port

**File Name:** This field allows the user to enter a name for the Port file.

**Capture:** This button will start/stop the capture of the caption service to the Port file.

**Status:** This field displays the status of the Port file.

**Comm Port:** This control allows the user to select which communication port traffic to save to the Procap file.

#### 5.15.2. Data Encode

**CEA-608 File:** Selecting this button allows the user to select the CEA-608 file to be encoded to video.

**Procap File:** Selecting this button allows the user to select the Procap file to be encoded to video

**CDP File:** Selecting this button allows the user to select the CDP file to be encoded to video

**SCC File:** Selecting this button allows the user to select the SCC file to be encoded to video



**Effective Timecode:** Displays the Effective Timecode as configured on the Time tab. This control was added to this tab for convenience.

**Status:** Displays the status of the current Data Encode operation.

## 5.16. FAULTS

This menu, as illustrated in Figure 5-17, allows the user to enable traps and monitor the trap fault status. To enable a particular trap, simply click the box located beside each trap so that a check-mark appears. When a check-mark is present, the trap is enabled. When a check-mark is not present, the trap is disabled.

If a parameter under the *Fault Status* is green, then the trap is in the non-fault state. If the parameter is red, then the trap is in the fault/error state.

Trap Enable	Fault Status
<input type="checkbox"/> Video A Present	<input checked="" type="checkbox"/> Video A Present
<input type="checkbox"/> Video B Present	<input checked="" type="checkbox"/> Video B Present
<input type="checkbox"/> Command Error (E1)	<input checked="" type="checkbox"/> Command Error (E1)
<input type="checkbox"/> Format Error (E2)	<input checked="" type="checkbox"/> Format Error (E2)
<input type="checkbox"/> Article Error (E4)	<input checked="" type="checkbox"/> Article Error (E4)
<input type="checkbox"/> Memory Error (E6)	<input checked="" type="checkbox"/> Memory Error (E6)
<input type="checkbox"/> Permission Error (E9)	<input checked="" type="checkbox"/> Permission Error (E9)
<input type="checkbox"/> SMPTE-333 Invalid	<input checked="" type="checkbox"/> SMPTE-333 Invalid
<input type="checkbox"/> SMPTE-333 NAK	<input checked="" type="checkbox"/> SMPTE-333 NAK
<input type="checkbox"/> SMPTE-333 Overflow	<input checked="" type="checkbox"/> SMPTE-333 Overflow
<input type="checkbox"/> SMPTE-333 Timeout	<input checked="" type="checkbox"/> SMPTE-333 Timeout
<input type="checkbox"/> Serial Overflow	<input checked="" type="checkbox"/> Serial Overflow
<input type="checkbox"/> Serial Underflow	<input checked="" type="checkbox"/> Serial Underflow
<input type="checkbox"/> Serial Framing Error	<input checked="" type="checkbox"/> Serial Framing Error
<input type="checkbox"/> Serial Overrun	<input checked="" type="checkbox"/> Serial Overrun
<input type="checkbox"/> Serial Parity Error	<input checked="" type="checkbox"/> Serial Parity Error
<input type="checkbox"/> Preset Load Error	<input checked="" type="checkbox"/> Preset Load Error
<input type="checkbox"/> Preset Save Error	<input checked="" type="checkbox"/> Preset Save Error
<input type="checkbox"/> CEA-608 Parity Error	<input checked="" type="checkbox"/> CEA-608 Parity Error
<input type="checkbox"/> HD Input Overflow	<input checked="" type="checkbox"/> HD Input Overflow
<input type="checkbox"/> Caption Delay Alarm	<input checked="" type="checkbox"/> Caption Delay Alarm
<input type="checkbox"/> Caption Error Alarm	<input checked="" type="checkbox"/> Caption Error Alarm
<input type="checkbox"/> Service Missing CC1	<input checked="" type="checkbox"/> Service Missing CC1
<input type="checkbox"/> Service Missing CC2	<input checked="" type="checkbox"/> Service Missing CC2
<input type="checkbox"/> Service Missing CC3	<input checked="" type="checkbox"/> Service Missing CC3
<input type="checkbox"/> Service Missing CC4	<input checked="" type="checkbox"/> Service Missing CC4
<input type="checkbox"/> Service Missing TXT1	<input checked="" type="checkbox"/> Service Missing TXT1
<input type="checkbox"/> Service Missing TXT2	<input checked="" type="checkbox"/> Service Missing TXT2
<input type="checkbox"/> Service Missing TXT3	<input checked="" type="checkbox"/> Service Missing TXT3

Figure 5-17: VistaLINK® Faults Tab

### 5.16.1. Error Messages

Table 5-4 lists non-fatal CDP error messages. These indicate corrupt CDPs **generated by equipment upstream of the 7825CCE-3G**. The 7825CCE-3G can account for these problems and, in most cases, properly clean and re-format the data on the output. This is done automatically by the 7825CCE-3G and troubleshooting will usually not be required.

<b>CDP RESERVED BIT ERROR</b>	Indicates “reserved” bits in the CDP do not have the correct value.
<b>CDP TIMECODE ERROR</b>	Timecode section contains invalid data.
<b>CDP SERVICE INFO ERROR</b>	Service Info section contains invalid data.
<b>CDP TIME SECTION MISSING</b>	A Timecode section was expected, but the CDP did not actually contain a Timecode section.
<b>CDP CC DATA SECTION MISSING</b>	A Caption data section was expected, but the CDP did not actually contain a Caption data section.
<b>CDP SERVICE INFO SECTION MISSING</b>	A Service Info section was expected, but the CDP did not actually contain a Service Info section.

**Table 5-4: CDP Non-fatal Errors**

Table 5-5: lists critical/fatal CDP error messages. These errors indicate invalid/corrupt CDPs **generated by equipment upstream of the 7825CCE-3G**. Troubleshooting needs to occur physically upstream of the 7825CCE-3G to correct these problems, should they occur. These errors are unrecoverable and the 7825CCE-3G will discard the data in affected CDPs.

<b>CDP BAD SECTION</b>	An unknown section ID has been encountered.
<b>CDP BAD ID</b>	A CDP does not start with the 0x9669 data ID.
<b>CDP BAD DATA COUNT</b>	Invalid data count in the CDP.
<b>CDP BAD LENGTH</b>	The actual CDP length does not match the data count.
<b>CDP BAD CHECKSUM</b>	The calculated checksum does not match the indicated checksum.
<b>CDP BAD FRAME RATE</b>	The value for the FRAME RATE in the header section is invalid.
<b>CDP BAD COUNT</b>	The CDP counter value in the header section is not the same as the value in the footer section.
<b>CDP CCP TOO SHORT</b>	The Caption Channel Packet (CCP) within a CDP is shorter than the length indicated in the header section.
<b>CDP CCP TOO LONG</b>	The Caption Channel Packet (CCP) within a CDP is longer than the length indicated in the header section.

**Table 5-5: CDP Fatal Errors**

Table 5-6 lists miscellaneous errors that may occur. These may indicate electrical problems with the 7825CCE-3G or malfunctions in a device that is connected to the 7825CCE-3G, depending on circumstances.

<b>SERIAL OVERFLOW SERIAL OVERRUN</b>	Indicates that data sent via serial port or modem has exceeded the size of the buffer to hold it, and was lost.
<b>SERIAL UNDERFLOW</b>	Indicates that the CPU attempted to get data from the serial port input buffer, but there was none available.
<b>SERIAL FRAMING ERROR SERIAL PARITY ERROR</b>	Indicates that communication settings of the 7825CCE-3G serial port or modem and the remote system are not identical. You may see this error if the baud rates are different as well.
<b>PRESET LOAD ERROR PRESET SAVE ERROR</b>	These error messages indicate error loading/saving presets to the non-volatile storage memory. Possibly correctable by performing a factory reset, or resetting preset storage from the bootloader.
<b>CEA-608 PARITY ERROR</b>	Indicates a parity error in CEA-608 caption data read from upstream video. You may also see this if there is excessive noise on SD line-21 or the caption level is too low.
<b>HD INPUT OVERFLOW</b>	Indicates that the volume of HD caption data coming in from upstream video has exceeded the ability to re-encode it, causing the internal buffers to overflow. This may occur as a result of the buffers being too small (code problem) or a result of oversize CDPs encoded in the upstream video (CDP/video problem).

**Table 5-6: Operational Errors**

Table 5-7 lists the serial command protocol errors that may occur as a result of problems with a device connected to one of the communication ports.

<b>COMMAND ERROR (E1)</b>	Indicates the command is not recognized.
<b>FORMAT ERROR (E2)</b>	Indicates the command parameter is not recognized.
<b>ARTICLE ERROR (E4)</b>	Indicates article name does not exist and/or article is invalid.
<b>MEMORY ERROR (E6)</b>	Indicates the 7825CCE-3G is out of memory for text or XDS article storage.
<b>PERMISSION ERROR (E9)</b>	Indicates a data stream is already allocated to another port.

**Table 5-7: Serial Command Protocol Errors**

Table 5-8 lists the SMPTE-333 Errors that may occur; these errors are only applicable when Port B Mode is set to SMPTE-333.

<b>SMPTE-333 Invalid</b>	Indicates a character was received that does not conform to SMPTE-333 Protocol.
<b>SMPTE-333 NAK</b>	Indicates a NAK character was received from the connected device.
<b>SMPTE-333 Timeout</b>	Indicates timeout waiting for a response from the connected device.

**Table 5-8: SMPTE-333 Errors**

Table 5-9 lists the Caption Delay and Errors alarms that may occur, these are configured on the OSD/Monitoring tab under the Caption Text Comparison settings (see section 5.7).

<b>Caption Delay Alarm</b>	Indicates the caption comparison delay exceeded the set threshold.
<b>Caption Error Alarm</b>	Indicates the number of errors per minute exceeded the set threshold.

**Table 5-9: Caption Delay Errors**

<b>Service Missing CC1-CC4</b> <b>Service Missing TXT1-TXT4</b> <b>Service Missing SVC1-SVC6</b>	Indicates the timeout waiting for output captions on the specified caption service.
--	---

**Table 5-10: Caption Service Inactive Errors**

Table 5-10 lists the Caption Service Inactive alarms that may occur; these are set on the CC Setup tab under the Service Inactive Duration controls (see section 5.3.4).

### **5.16.2. Correcting Caption Errors Automatically**

The 7825CCE-3G has the ability to automatically correct for various errors that might be detected in the input captions. The 7825CCE-3G reads each CDP, buffers the data on a per-service level, and rebuilds new CDPs on the output. It can also look at the incoming CEA-608 data in the CDPs and translate it into comparable CEA-708 data. From these functions it can fix numerous problems such as:

- Bits marked as "reserved" that not at levels specified by standard.
- Sequence counter discontinuities.
- Header signaling optional sections that are not actually present in the CDP.
- CDPs on the wrong field or both fields of interlaced video (should only appear on first field of each frame).
- CDPs that are the wrong length for the detected video standard.
- Wrong amount of CEA-608 data in CDPs (always want 120/1.001 characters per second of 608 data regardless of video frame rate).
- Poor CEA-608 to CEA-708 translation (by ignoring upstream 708 and re-translating from 608).
- Multiple CCPs per CDP (not an error but not compatible with some equipment).
- CCPs that are split across multiple CDPs (not an error but not compatible with some equipment).
- Relocate CDPs to the specified line.
- Prevent data from CDPs that are likely corrupted from passing (see list of critical/fatal errors in Table 5-5:).

## 6. SERIAL COMMAND PROTOCOL

The following sections present the command protocol for the 7825CCE-3G closed caption encoder. Section 6.1 provides a quick cross-reference to the command set. Sections 6.2 to 6.6 provide a full description of the commands with examples.

### 6.1. COMMAND QUICK REFERENCE

<b>Serial Command Cross-Reference</b>			
	<b>Command</b>	<b>Function</b>	<b>Section</b>
<b>Control &amp; Status</b>	^A?	Report Firmware Version	6.3.6
	^Ac	Set/Report Time of Day	6.3.10
	^Ad	Set/Report Date	6.3.11
	^AE	Set Output Line	6.3.3
	^AI	Set Baud Rate	6.3.1
	^AH	Command Help Message	6.3.7
	^AM	Controlling the Caption Decoder	6.3.5
	^AA	Display System Status	6.3.16
	^AS	Report Bypass Status	6.3.8
	^AY	Report Battery Status	6.3.9
	^A5	Monitor Encoded Data	6.3.4
	^F^F	Reset Encoder	6.3.2
<b>Captioning State</b>	^A2	Real Time State	6.3.15
	^A3	Direct Control State	6.3.14
	^A6	Null State	6.3.13
	^A7	Transparent State	6.3.12
<b>Text Articles</b>	^A0	Input Article	6.4.1
	^A1	Output Article	6.4.2
	^A4	Delete article	6.4.3
	^A8	Queue Articles	6.4.4
	^A9	Display Article Status	6.4.5
	^AB	Display Output Queue	6.4.6
<b>XDS Encoding</b>	^AP	Input XDS Packet	6.5.1
	^AP	Block Upstream XDS Packet	6.5.2
	^A8	Queue XDS Packets	6.5.3
	^AP	Delete XDS Packets	6.5.4
<b>Comm. Port Control</b>	^AQ	Show Port Permission Maps	6.6.1
	^AQ	Alter Port Permission Maps	6.6.2
	^AO	Show Ports Active Maps	6.6.3
	^AO	Alter Ports Active Maps	6.6.4
	^Ar	Reset Port	6.6.5

**Figure 6-1: Command Quick Reference**

## 6.2. COMMAND SYNTAX DESCRIPTION

The Command line shows the required information in **bold underlined text**. Optional parameters are shown in **bold normal text**. The default line shows the parameter values that will be invoked if the optional parameter(s) are omitted. Many of the commands use control characters which are indicated by a carat character '^' preceding a letter. (E.g. Control-A is shown as ^A). Other special characters are shown enclosed in <brackets>. (See section 6.2.1 for a description of the control characters and special characters and their ASCII values). (All ASCII values are shown in hexadecimal notation). Parameters are shown in lower case. (See section 6.2.2 for a description of the parameters and their values). All upper case alphanumeric characters that are not preceded by the carat or enclosed in brackets are to be interpreted as individual characters. (E.g. F1 is an 'F' followed by a '1').

### 6.2.1. Special Characters

Most commands use control characters to communicate with the encoder. The chart below shows the designators for the control characters and other special characters that are used in the command descriptions:

Designator	Name	ASCII Values (Hex)
<b><u>^A</u></b>	Control-A	01
<b><u>^B</u></b>	Control-B	02
<b><u>^C</u></b>	Control-C	03
<b><u>^F</u></b>	Control-F	06
<b><u>^G</u></b>	Control-G	07
<b><u>^H</u></b>	Control-H (backspace)	08
<b><u>^X</u></b>	Control-X (delete line)	18
<b><u>&lt;sp&gt;</u></b>	Space	20
<b><u>&lt;cr&gt;</u></b>	Carriage Return	0D
<b><u>&lt;xon&gt;</u></b>	Start transmission	11
<b><u>&lt;xoff&gt;</u></b>	Halt Transmission	13

### 6.2.2. Parameters

Some commands use parameters with variable values. The command descriptions use a generic designator to indicate these parameters. The chart below shows each of the designators with their meanings and the permitted values. The values shown are the actual characters to be inserted into the command message. Normally parameters should be separated from each other by a <sp>.





Designator	Name	Values	Description
fx	Field Number	F1	Field 1
		F2	Field 2
dc	Data Channel	C1	Caption Channel 1
		C2	Caption Channel 2
		C3	Caption Channel 3
		C4	Caption Channel 4
		T1	Text Channel 1
		T2	Text Channel 2
		T3	Text Channel 3
		T4	Text Channel 4
		XD	Extended Data Services Channel
		For compatibility with older software the following designators are also used to describe caption data channels:	
		CC1	Caption Channel 1
		CC2	Caption Channel 2
CC3	Caption Channel 3		
CC4	Caption Channel 4		
tc	Text Channel	T1	Text Channel 1
		T2	Text Channel 2
		T3	Text Channel 3
		T4	Text Channel 4
		For compatibility with older software the following designators also refer to the text channels:	
		L1	Text Channel 1
		L2	Text Channel 2
		L3	Text Channel 3
		L4	Text Channel 4

Designator	Name	Values	Description
name	Article Name		1 to 8 alphanumeric character article name
edsid			XDS packet Id input as 2 ASCII hex digit class followed by 2 ASCII hex digit type. (cctt). Valid class numbers are: 01, 03, 05, 07, 09, 0B, 0D. Leading zeros of the class numbers are optional.  In cases where the class and type bytes are not sufficient to uniquely distinguish the packets, (such as for 0D05 packets) the first 2 digits of the packet data may also be appended to the end of the edsid. (ccttdd)

<b>k/d</b>	Keep/Delete	K	Keep article
		D	Delete article
<b>o/h</b>	Output/Hold	O	Place article in output queue
		H	Do not place article in output queue
<b>n/l</b>	Next/Last	N	Place article next in output queue
		L	Place article at the end of output queue
<b>rc</b>	Repeat Count	0 to 9998	Decimal number of times to repeat article
		9999	Repeat indefinitely
		FFFF	Repeat indefinitely
		hh:mm:ss	Repeat until this time is being requested by the computer (Current software treats this as equivalent to 9999)
<b>ln</b>	Output Line	10 to 25	
<b>bl</b>	Caption Base Line	1 to 15	Base line of caption rollup display
<b>rl</b>	Caption Rollup Lines	2 to 4	Number of lines of rollup captions
<b>pn</b>	Port Name	P1, PA, EN1	Port A
		P2, PB, EN2	Port B
		P3, PC, EN3	Port C
		P4, MA, MD EN4	modem D
		P5, MB, ME, EN5	modem E (if installed)
<b>dt</b>	Data Type	CF1	Captions field 1
		CF2	Captions field 2
		TF1	Text field 1
		TF2	Text field 2
		XDS	Extended data services

Designator	Name	Values	Description
<b>ws</b>	Word size	7	7 bit data word
		8	8 bit data word
<b>par</b>	Parity	O	Odd parity
		E	Even parity
		N	No parity
<b>tz</b>	Time zone	0:00 to 23:59	Time zone hours and minutes relative to UTC
<b>ovr</b>	Override	O	Forces override

### 6.2.3. Flow Control Handshaking

When the encoder's input buffer is nearly full the device sends an XOFF for each character received. If the Caption software continues to send data and the input buffer fills completely, and creates a buffer overflow state. When the input buffer has overflowed some data may be lost. When the input buffer is nearly empty the caption encoder will transmit an XON character. The 7825CCE-3G uses hardware flow control to prevent lost data. The unit will turn off the RS232 RTS signal when the buffer is nearly full, and will turn RTS on when the input buffer is nearly empty.

### 6.2.4. Break Handling

A break character can be sent to the caption encoder to cause the content of the associated input buffer to be discarded. If the break character is sent to the modem port the modem character buffers will also be discarded. This allows the user to circumvent a backlog of data input, and regain immediate control of the encoder. The best way to reset a communications port is to send a break followed by a Control-F – Control-F command.

### 6.2.5. Command Responses

When the 7825CCE-3G accepts any of the Control-A commands it will respond by sending back an asterisk '\*' prompt with the following exceptions:

When in real time mode it will respond with a colon ':' prompt.

When an article is being defined it will respond with a '>'.

## 6.3. COMMON COMMANDS

### 6.3.1. Set Baud Rate

The caption encoder's serial remote control ports may be set to operate at any standard baud rate from 1200 to 57600. When this command is executed the new baud rate will become immediately active, and the sending computer must immediately switch to the new rate. The new baud rate is stored in non-volatile memory and will be restored when the unit is powered up.

The modem ports may have a lower maximum baud rate that is related to the maximum baud rate of the built-in modems. The baud rate for the modem ports will also limit the maximum connection rate that the modems will allow.

**Command:** ^A|<sp>pn<sp>baud<sp>ws<sp>par<cr>  
or ^A|<cr>

**Default:** none

The parameter baud specifies the baud rate that will be used. The permitted values of parameter baud are shown in the table below.

Parameter	Baud Rate
<b>12</b>	1200
<b>1200</b>	1200
<b>24</b>	2400
<b>2400</b>	2400
<b>48</b>	4800
<b>4800</b>	4800
<b>96</b>	9600
<b>9600</b>	9600
<b>192</b>	19200
<b>19200</b>	19200
<b>384</b>	38400
<b>576</b>	57600

If the optional port name parameter is missing, then the current control port will be assumed. If no parameters are specified, the 7825CCE-3G will respond with a report of the communication parameters of all the COMM ports as shown below.

**Port A:** 1200 7 Odd  
**Port B:** 9600 8 None  
**Port C:** 1200 7 Odd  
**Port D:** 4800 8 None

**Examples:**    `^Al<sp>19200<cr>`                               Set baud rate to 19200  
                  `^Al<sp>P1<sp>96<sp>8<sp>N`               Sets Port A to 9600,8,N

### 6.3.2. Reset Encoder

This command immediately clears the input and output data queues and resets the 7825CCE-3G to the Transparent State in Field 1 and Field 2. Article and XDS output queues are not reset by this command. They must be explicitly reset by using the queue articles and queue XDS commands. (See sections 6.4.4 and 6.5.3.) To reset only a particular communications port, refer to the Reset Port (^Ar) command in section 6.6.5.

**Command:**    `^F^F<cr>`

**Default:**     none

### 6.3.3. Set Output Line

The normal line for caption information is line 21 in SD-SDI. This command allows the 7825CCE-3G to output caption information on different line numbers. This command also changes the line number used by the decoder.

**Command:**    `^AE<sp>Lln<cr>`

**Default:**     `^AE<sp>L21<cr>` for SD-SDI systems



### 6.3.6. Report Firmware Version

The caption encoder will respond with a message identifying its firmware version and port name.

**Command:** `^A?`

Returns Evertz 7825CCE-3G Ver:CK88D5 U000427 -- Use ^AH{return} for help  
Port B (Example)

### 6.3.7. Command Help

This command returns a help message from the caption encoder.

**Command:** `^AH<cr>`

**Default:** none

**Returns:**

Cmds supported - ^C,^F,...

^A +0,1,2,3,4,5,6,7,8,9,A,B,c,E,H,I,M,O,P,Q,r,t,u,S,Y,?

### 6.3.8. Report Bypass Switch Mode

This command returns a message that shows the status of the video bypass relay and the caption keyer.

**Command:** `^AS<cr>`

**Example results:**

REMOTE OVERRIDE indicates that the keyer is disabled but video will be passed through the 7825CCE-3G.

EXTERNAL BYPASS indicates the SDI bypass relay has been activated by an external signal.

LOCAL BYPASS ON indicates the SDI bypass relay has been activated by the 7825CCE-3G menu selection.

### 6.3.9. Report Battery Status

This command will return the status of the internal battery

**Command:** `^AY<cr>`

**Example results:** Battery OK

### 6.3.10. Set / Report Time of Day Clock

This command will return the current time of day or will allow the internal clock to be set. The unit will maintain the correct time even through power outages.

**Command:** `^Ac<cr>`

**Example results:**

Local time is 13:47:39, Time zone is 05:00, DST is ON, DSO is ON

**Command:** `^Ac<sp>U<cr>`

### Example results:

UTC is 19:47:39, Time zone is 05:00, DST is ON DSO is ON

**Command:** `^Ac<sp>hh:mm:ss<sp>hh:mm<sp>dst<sp>DSO=dso<cr>`

hh:mm:ss	Local time
hh:mm	Time zone offset
dst	OFF Daylight Saving Time not in effect (DST Bit Off)
	ON Daylight Saving Time in effect (DST Bit On)
dso	OFF Daylight Saving Time not observed in this region (DSO Bit Off)
	ON Daylight Saving Time observed in this region (DSO Bit On)



**Although the time zone must be entered as hours and minutes, the XDS Time Zone packet will only transmit the time zone hours. This is a limitation of the definition of the time zone packet in CEA-608.**

**Example:** `^Ac<sp>13:10:00<sp>5<sp>ON<sp>DSO=ON<cr>`  
Set local time to 1:10 pm in EDT (Daylight Saving Time in effect), Daylight Saving Time observed.

`^Ac<sp>13:10:00<sp>5<sp>ON<sp>DSO=OFF<cr>`  
Set local time to 1:10 pm in EST (Daylight Saving Time in effect), Daylight Saving Time not observed. (i.e. As in Indiana)

`^Ac<sp>06:10:00<cr>`  
Set local time to 6:10 am. Time zone, DST and DSO unchanged.

`^Ac<sp>13:10:00<sp>4:30<sp>OFF<sp>DSO=ON<cr>`  
Set local time to 1:10 pm in Newfoundland Time Zone with Daylight Saving Time not in effect, but Daylight Saving time observed

The DST bit instructs the encoder whether Daylight Saving Time is currently in effect. The DSO bit instructs the encoder whether Daylight Saving Time is observed in this region. The encoder must know this information when converting between local time and UTC time internally. Most regions in North America observe Daylight Saving Time according to the following rule: ON in the summer; starting on the second Sunday in March. OFF in the winter; starting on the first Sunday in November. Other parts of the world follow different rules for DST.

### 6.3.11. Set / Report Calendar Date

This command will return the current calendar date or will allow the internal calendar date to be set. The encoder will maintain the correct date even through power outages.

**Command:** `^Ad<cr>`

**Example results:**

Local date is: Jan/09/2000 Mon.

**Command:** ^Ad<sp>U<cr>

**Example results:**

UTC date is: Jan/10/2000 Mon.

**Command:** ^Ad<sp>mm/dd/yyyy<sp>day of week<sp>U<cr>

**Example:** ^Ad<sp>01/26/2000<sp>4<cr>  
Set local date to January 26, 2002 and day is Wednesday.

^Ad<sp>03/25/2001<cr>  
Set local date to March 25, 2003. No day of week indicated.

^Ad<sp>12/21/2001<sp>7<sp>U<cr>  
Set UTC date to December 21, 2003.

### 6.3.12. Transparent State

In Transparent state, incoming line 21 video in the respective data stream will be copied to the output.

**Command:** ^A7<sp>fx<cr>  
^A7<sp>dc<cr>

**Default:** ^A7<sp>F1<cr>

In the first form of the command, the optional parameter **fx** identifies the field (i.e. all streams in that field) that will be placed in the transparent state.

In the second form of the command the parameter **dc** identifies the data stream that will be placed in transparent state.

<b>Examples:</b>	<u>^A7</u> <sp>F1<cr>	Field 1 in transparent state
	<u>^A7</u> <sp>C1<cr>	Captions 1 in transparent state
	<u>^A7</u> <sp>T2<cr>	Text 2 in transparent state
	<u>^A7</u> <sp>TX<cr>	XDS stream in transparent state

### 6.3.13. Null State

In the Null state, the encoder will insert Null characters for the selected data stream into line 21. Incoming line 21 video will not be copied through on the data stream.

**Command:** ^A6<sp>fx<cr>  
^A6<sp>dc<cr>

**Default:** ^A6<sp>F1<cr>

In the first form of the command, the optional parameter **fx** identifies the field (i.e. all streams in that field) that will be placed in the Null state.



In the second form of the command the parameter **dc** identifies the data stream that will be placed in the Null state.

**Examples:**    `^A6<sp>F1<cr>`                   Field 1 in Null state  
                 `^A6<sp>C1<cr>`                   Captions 1 in Null state  
                 `^A6<sp>T2<cr>`                   Text 2 in Null state  
                 `^A6<sp>TX<cr>`                   XDS stream in Null state

### 6.3.14. Direct Control State

This command causes the encoder to enter the Direct Control state. The Direct Control state is normally terminated by sending the End Of State command (^C), which will cause the encoder to revert to the Null state.

**Command:**    `^A3<sp>n<sp>fx<cr>data . . . data^C`  
                  or  
                  `^A3<sp>n<sp>dc<cr>data . . . data^C`

**Default:**     `^A3<sp>4<sp>F1<cr>`

In the first form of the command, the optional parameter **fx** identifies the field (i.e. all streams in that field) that will be placed in the Direct Control state. In the Direct Control state, caption information is inserted into the appropriate video field in one of the four modes that are described below. All upstream caption and text data in that field will be blocked. Any articles queued for insertion to that field will also be blocked. The computer supplies all the information for that field, formatting it with the appropriate stream control codes.

In the second form of the command, the optional parameter **dc** identifies the data channel that will be placed in the Direct Control state. All upstream caption and text data in the specified data channel will be blocked. Any articles queued for insertion to that data channel will also be blocked. The computer supplies all the information for that data channel, formatting it with the appropriate stream control codes. All caption information in the non-specified data channels will be passed through.

The optional parameter **n** identifies which variation of the Direct Control state will be used.

**n=1**    provides the same processing as n=2.

**n=2**    means that legitimate line 21 control codes are aligned and delayed so that the two byte control code pairs are transmitted in the same field.

**n=3**    means that legitimate line 21 control codes are aligned and delayed so that the two byte control code pairs are transmitted in the same field. Each control code pair is sent twice.

**n=4**    provides the same processing as for n=3. No non-line 21 codes are transmitted and the control codes are converted (if necessary) to the correct equivalent code for the current video field.

<b>Examples:</b>	<code>^A3&lt;cr&gt;</code>	Field 1 in Direct Control mode 4
	<code>^A3&lt;sp&gt;&lt;cr&gt;</code>	Field 1 in Direct Control mode 4
	<code>^A3&lt;sp&gt;1&lt;cr&gt;</code>	Field 1 in Direct Control mode 1
	<code>^A3&lt;sp&gt;F2&lt;cr&gt;</code>	Field 2 in Direct Control mode 4
	<code>^A3&lt;sp&gt;3&lt;sp&gt;F1&lt;cr&gt;</code>	Field 1 in Direct Control mode 3
	<code>^A3&lt;sp&gt;C1&lt;cr&gt;</code>	Caption channel 1 in Direct Control mode 4
	<code>^A3&lt;sp&gt;3&lt;sp&gt;T1&lt;cr&gt;</code>	Text channel 1 in Direct Control mode 3

### 6.3.15. Real Time State

In Real Time state, incoming data from the caption computer is transferred as it is typed into the appropriate data stream. The line may be edited using `^H` (backspace) or `^X` (delete line). A delay of 1 to 9 seconds can be inserted by including `^Bn` into the data (n is the number of seconds of delay desired).

If a caption data channel is specified, captions will be in rollup format with a specified number of lines. The default format is 3 line caption rollup for caption data channels and text format for text channels.

When the data channel is put into the real time state, upstream data on the specified channel will be blocked from entering the output queue of the encoder. All subsequent data is part of the data stream until `^C` is received or the encoder is reset. If the specified data stream is a text channel, articles will be suspended from the output queue while the real time state is active. All caption information in the non-specified data channels will be passed through.

Real Time state is normally terminated by a `^C`. Articles will be re-enabled into the output queue starting with the suspended article. If upstream data was enabled prior to entering the Real Time State then it will be re-enabled when the Real Time state is terminated.

**Command:** `^A2<sp>dc<sp>rl<sp>Bbl<cr>`

**Default:** `^A2<sp>C1<sp>3<sp>B15<cr>`

The parameter **dc** identifies the data channel that will be placed in the Real Time state.

The **rl** parameter identifies the number of rollup rows and the **bl** parameter identifies the base line if the **dc** parameter is one of the caption data channels. If the base line is specified the roll up line must also be specified.

#### Examples:

<code>^A2&lt;cr&gt;</code>	Caption 1 in Real Time State with 3 line rollup at base line 15
<code>^A2&lt;sp&gt;T2&lt;cr&gt;</code>	Text 2 in Real Time State
<code>^A2&lt;sp&gt;C3&lt;sp&gt;2&lt;cr&gt;</code>	Caption 3 in Real Time State with 2 line rollup at base line 15
<code>^A2&lt;sp&gt;C4&lt;sp&gt;3&lt;sp&gt;B10&lt;cr&gt;</code>	Caption 4 in Real Time State with 3 line rollup at base line 10

### 6.3.16. Display System Status

This command displays the upstream line 21 data channels that are turned on (i.e.: upstream data being passed through to the output) and the number of bytes of memory remaining to store articles and XDS packets.

**Command:** `^AA<cr>`

**Default:** none

**Examples:** ^AA<cr>

**Returns:**

**Example with all channels On:**

```
Memory Status: Avail-005453 # Segments-000011 Largest Avail-005453
Channel Status:
Field 1:C1 C2 T1 T2 ON
Field 2:C3 C4 T3 T4 XD ON
```

**Example with all channels On except T3:**

```
Memory Status: Avail-005453 # Segments-000011 Largest Avail-005453
Channel Status:
Field 1:C1 C2 T1 T2 ON
Field 2:C3 C4 T4 XD ON
```

## 6.4. TEXT ARTICLES

When the Article state is active, text data can be entered and stored as complete messages. These messages can be transmitted in any order, any number of times, in any of the text channels. Display attributes contained within the articles (such as colour, etc.) specifically coded for one data stream will be translated into the appropriate codes for the text channel they are ultimately inserted into.

The message can be kept in memory or deleted when you have finished transmitting it. Articles will be lost from the article memory in the event of a power loss. The 7825CCE-3G uses an advanced memory allocation scheme that enables it to store a virtually unlimited number of articles at one time. The only requirement is the maximum amount of random access memory available.

The command protocol allows editing of each line of the message by use of the ^H (backspace) and ^X (delete line) characters before the <cr> is input. A delay of 1 to 9 seconds can be inserted into the article by inserting ^Bn into the article. (n is the number of seconds of delay desired)

Once a text channel is put into Article state, upstream data on that channel will be blocked from the output queue. A data channel will be in the article state as long as any article is assigned to its output queue.

### 6.4.1. Input Article

This command allows the user to input an article to the article memory and assign it to the output queue of one of the text data channels.

**Command:** ^A0<sp>name<sp>tc<sp>rc<sp>k/d<sp>o/h<sp>n/l<cr>  
data<cr>data . . .data<cr>^C

**Default:** ^A0<sp>name<sp>T1<sp>9999<sp>D<sp>O<sp>L<cr>

The parameter **name** identifies the name of the article. The article can subsequently be referred to by its name. If the article name already exists, the new article with the same name will replace the previous article.

The **tc** parameter identifies the text channel number that the article will be placed into.

The **rc** parameter identifies the number of times the article will be repeated. Values of 9999 or FFFF indicate that the article should be repeated indefinitely. An article's repeat count will be decremented each time the article is output in each output data stream.

The **k/d** parameter identifies whether the article should be kept or deleted when it has been transmitted the specified number of times.

The **o/h** parameter identifies whether the article should be placed into the output queue or whether it should just be held in memory for later use.

The **n/l** parameter identifies whether the article should be placed as the first article in the output queue or the last article in the queue.

All subsequent data is part of the article until ^C is received. The encoder will respond to each line of the article with a '>' prompt while the article is being defined.

**Examples:**    ^A0<sp>Test<sp>T1<sp>5<cr>  
                  This is the first line<cr>  
                  and this is the last line ^C

A two line article called 'Test' will be placed at the end of the Text 1 output queue. The article will be deleted after it is output 5 times.

#### **6.4.2. Output Article**

This command allows the user to put an existing article (defined by the Input article command) into the output queue of the specified text data channels. An article may be put into an output queue more than once.

**Command:**    ^A1<sp>name<sp>tc<sp>rc<sp>k/d<sp>o/h<sp>n/l<cr>

**Default:**

tc	last text channel the article was sent to
rc	current repeat count
k/d	last keep/delete status specified for the article
o/h	O
n/l	last next/last status specified for the article

The parameters have the same meaning as for the Input article command. If the **o/h** parameter is H then this command may be used to change other attributes of the article without outputting it.

The parameter **name** specifies the name of a previously defined article.

If the parameter **k/d** is D, and the article is currently being output, it will not be removed until it has been completely output.

**Examples:**    ^A1<sp>Test<sp>T2<sp>5<sp>D<cr>

The article called 'Test' will be placed at the end of the Text 2 output queue. The article will be deleted after it is output 5 times.

^A1<sp>Test<sp>T2<sp>9999<sp>H<cr>

The article called 'Test' will have its repeat count change to indefinite. It will not be placed into any of the output queues.

#### 6.4.3. Delete Article

This command allows the user to remove an article from all output queues. If the article is currently being output, it will not be removed until it has been completely output.

**Command:** `^A4<sp>name<sp>k/d<cr>`

**Default:**

**k/d** last keep/delete status specified for the article

The parameter **name** identifies the name of the article.

The parameter **k/d** indicates whether the article will be deleted from memory or not.

**Examples:** `^A4<sp>Test<sp>D<cr>`

The article called 'Test' will be removed from all output queues and deleted from memory.

#### 6.4.4. Queue Articles

This command will delete the entire specified output queue and replace it with the articles named (if any). The user enters the names of the articles separated by <cr> in the order that they are to appear in the output queue. The encoder continues to add articles to the queue until it receives a ^C. The article names may be edited by using the ^H (backspace) and ^X (delete line) characters before the <cr> is input.

**Command:** `^A8<sp>tc<cr>  
name<cr>name<cr>....name<cr>^C`

**Default:** none

The parameter **tc** identifies the text channel number of the output queue the articles will be placed into.

The parameter **name** identifies the name of each article to be placed in the queue. If no article names are given, the specified article output queue is cleared and no articles will be output in that data stream.

**Example:** `^A8<sp>T1<cr>TEST<cr>TEST2^C`

Puts the previously defined articles named TEST and TEST2 into the output queue for Text Channel 1.

#### **6.4.5. Display Article Status**

This command allows the user to view the list of articles stored in the article memory and display their status. The status includes the article name, repeat count, (9999 if infinite) the keep/delete status, and the memory storage needed for the article. The first line of the article will also be shown. A “...” will indicate multiple lines of text.

**Command:** ^A9<cr>

**Default:** none

**Examples:** ^A9<cr>

**Returns:**

```
Article Status:
Name          Repeat K/D size text
test1         009999 D 000031 "this is a sample"...
test2         009999 D 000014 "second article"
```

#### **6.4.6. Display Output Queue**

This command displays the articles in all 5 output queues in the order in which they reside in the queues.

**Command:** ^AB<cr>

**Default:** none

**Examples:** ^AB<cr>

**Returns a list of articles such as the following:**

```
Output Q: T1
test1
Output Q: T2
test2 test2
Output Q: T3

Output Q: T4

Output Q: XDS
```

## 6.5. EXTENDED DATA SERVICES

Extended Data Services (XDS) information is encoded into Field 2 and is intended to supply program related and other information to the viewer. XDS data can inform the viewer of such information as current program title, length of show, type of show, time left in show, and V-Chip-compatible program rating information.

The XDS output stream consists of a distinct XDS packet for each type of information. Each packet consists of a 1 byte class, a 1 byte type, one or more informational characters, a 1 byte end of packet code, and a 1 byte checksum.

XDS packets are stored in the article memory and output in the XDS data channel in Field 2. These packets are placed into the XDS output queue in the order specified by the user and inserted into Field 2 according to the space available. CEA-608-B specifies that when there is caption or XDS information in field 2, then there must be at least a null caption signal present in field 1 as well. When encoding into field 2, the 7825CCE-3G automatically detects whether there is a caption signal present in field 1. If necessary, it will turn on the Field 1 keyer automatically and turn it off again when upstream field 1 captions resume.

The computer uses an ASCII hex notation in describing the XDS packet id and data to the caption encoder. For example, to specify the letter A enter a 4 followed by a 1 (the hex ASCII code for A is 41)

The XDS packets are deleted from memory when they have been transmitted the specified number of times. XDS packets will be lost from the encoder's memory in the event of a power loss. The 7825CCE-3G uses an advanced memory allocation scheme that allows it to store a virtually unlimited number of XDS packets at one time. The only limit is the total amount of random access memory available.

Upstream XDS packets will be blocked in the output queue by packets of the same type.

### 6.5.1. Input XDS

This command allows the user to input an XDS packet into the caption encoder's article memory.

If an XDS packet with identical **edsid** exists it will be deleted and replaced with the new packet definition.

**Command:** ^AP<sp>edsid<sp>rc<sp>data...data<cr>

**Default:** none

The **edsid** parameter identifies the XDS packet id. The XDS packet can subsequently be referred to by its packet id. If the XDS packet already exists, the new packet with the same id will replace the previous XDS packet. The **edsid** is entered in ASCII hex notation. For example, to enter a packet id with a class of 01h and a type of 23h, enter a 0 followed by a 1 followed by a 2 followed by a 3. The leading zero of the class is optional.

The **rc** parameter identifies the number of times the packet will be repeated. Values of 9999 or FFFF indicate that the packet should be repeated indefinitely. A packet's repeat count will be decremented each time it is output.

The parameter **data** is the information bytes of the packet. This data is entered in ASCII Hex format. For example, to enter the letter A enter a 4 followed by a 1 (the hex ASCII code for A is 41)

The XDS article length is checked for the following commonly used articles: Program ID (0101), V-Chip Content Advisory (0105), Station Call Letters (0502), and Time Zone (0704). If the article length is not in the valid range for the packet type, the encoder will reject it. This length checking does not apply to XDS packets from upstream, only XDS articles that are entered using the ^AP command from a serial port.

**Examples:**

```
^AP<sp>0103<sp>10<sp>41424344<cr>
```

Sets the program name packet to ABCD and repeat packet ten times.

```
^AP<sp>0701<sp>9999<sp>456A4548474A<cr>
```

Time Of Day packet indicating the current UTC time is 10:05 am on Saturday, October 5<sup>th</sup>, 2002. DST is ON. The packet will be repeated indefinitely.



**Time of Day and Time Zone packets behave differently than other XDS articles when defined. The defined packet contents will be ignored; the encoder will generate the time of day packet data from the current internal time.**

```
^AP<sp>0105<sp>9999<sp>486D<cr>
```

Program rating packet setting the rating system to "TV Parental Guideline", rating of TV-PG with V and L bits set. The packet will be repeated indefinitely. Other V-Chip ratings may be encoded using the information in Appendix A.

**6.5.2. Blocking Upstream XDS Packets**

Upstream XDS packets can be removed entirely from the data stream, without having to insert new XDS data of the same type. This is accomplished using a variation of the ^AP serial interface command. This feature is particularly useful for removing unwanted Time-of-Day packets, Time Zone packets, etc. off of pre-encoded material.

To remove a specific XDS packet, use the ^AP command to enter an XDS article with the packet id of the packet you want to remove, a repeat count of 9999 and article text consisting of the single character "R", or the equivalent ASCII HEX "52".

**Examples:**

```
^AP<sp>0701<sp>9999<sp>52<cr>
```

```
^AP<sp>0701<sp>9999<sp>R<cr>
```

Both variations block upstream Time Of Day packets

```
^AP<sp>0701<cr>
```

Allows upstream Time Of Day packets to be passed through



**Upstream XDS blocking instructions are not saved through power loss.**



### 6.5.3. Queue XDS Packets

This command will delete the entire specified XDS output queue and replace it with the packets named (if any). The user enters the packet ids of the XDS packets separated by <cr> in the order that they are to appear in the output queue. The user enters the packet id of each packet separated by <sp> in the order that they are to appear in the output queue.

**Command:** ^A8<sp>F2 edsid<sp>edsid...edsid<cr>

**Default:** none

The parameter **edsid** identifies the packet id of each packet to be placed in the XDS queue. If no packet id is given, the XDS output queue is cleared and no XDS information will be output.

### 6.5.4. Delete XDS Packet

This command allows the user to remove an XDS packet from the article memory. If the XDS packet is currently being output, it will not be removed until it has been completely output.

**Command:** ^AP<sp>edsid<cr>

**Default:** none

The **edsid** parameter identifies the packet to be deleted.

**Examples:** ^AP<sp>0103<cr>  
The program name packet will be removed from memory.

### 6.5.5. Inserting XDS Articles into Non-Volatile Memory

The 7825CCE-3G can store XDS articles in non-volatile memory, so that in case of a power failure, XDS information can be retained. All XDS articles starting with "05" (channel class) and "07" (miscellaneous class) are preserved in non-volatile memory. Other classes are not stored through a power low, and must be re-entered by the user upon power up.

## 6.6. COMM PORT CONTROL COMMANDS

The 7825CCE-3G enables the communication ports to simultaneous access the caption keyers. This can be the effective equivalent of multiple caption encoders linked in a series. By using a single video keyer, these encoder models provide the added advantage of minimizing the delays and the impact on the video quality. Several commands are provided in order to prevent data conflicts and allow the user to control which ports can affect the data. The caption encoder maintains a permission list that indicates which ports will be allowed to alter various kinds of data. The permissions for each port can be set from VistaLINK® menus or they may be set from the communication control ports. The permission list is maintained in non-volatile memory. The data types are denoted as follows:

<b>Data Type</b>	C1	captions field 1
	C2	captions field 2
	T1	text field 1
	T2	text field 2
	XDS	extended data services

When multiple ports are permitted access to a particular data type, conflicts will be resolved on a “first come, first served” basis. The caption encoder maintains a list of which ports are active for each data type.

Normally, the various keyer commands (such as ^A2, ^A3, ^A6, ^A7) will set and clear the active status automatically. To obtain maximum compatibility with existing software, these commands will exhibit the following special behavior:

If a port does not have permission for the full field 1, but does have permission for the captions in field 1, then the command will not be denied, but will revert to the C1 form of the command.

For example, if Port A has permission for CF1 only, and a ^A3<cr> or ^A3 F1<cr> is issued, then although Port A does not have permission for the full field 1, the command will not be rejected. Instead, the command will be treated as though ^A3 C1<cr> had been sent.

### 6.6.1. Show Port Permission Maps

This command will report the permission map for each port. The permission map controls what data types a port is allowed to become active in. (e.g., captions field 1, text field 2, XDS, etc.)

**Command:** ^AQ<cr>

#### Example result:

```
Permission Map
PORT A: C1 C2 T1 T2 XDS
PORT B: C1 C2 T1 T2 XDS
PORT C: C1 C2 T1 T2 XDS
PORT D: C1 C2 T1 T2 XDS OFFLINE
```

This example shows that all ports are permitted access to all data types (the factory default setting) and the Port D modem is offline.

#### Permission Map

```
PORT A: C2 T1 T2 XDS
PORT B: C1 T1 T2 XDS
PORT C: C1 C2 T2 XDS
PORT D: C1 C2 T1 T2 ONLINE
```

This example shows that Port A is denied access to captions in field 1, Port B is denied access to captions in field 2, Port C is denied access to text in field 1 and Port D is online and is denied access to extended data services.

### 6.6.2. Alter Port Permission Maps

This command will alter the permission map for any port by adding or subtracting various data types.

**Command:** ^AQ<sp>pn<sp>-dt...dt...dt<cr>

**Default:** none

**Example:**

```
^AQ PB - XDS -T2 -C2 C1 T1<cr>
```

This command will disallow Port B from all field 2 data types, and enable Port B for captions and text in field 1.

```
^AQ C1<cr>
```

This command will allow the current port to access captions in field 1. Permissions for other data types remain as previously set.

```
^Au<cr>
```

```
^AQ PD - XDS -T2 -C2 -T1 C1<cr>
```

```
^AQ PB -XDS -T2 -C2 -C1 T1<cr>
```

```
^AQ PC -T2 -C2 -C1 -T1 XDS<cr>
```

These commands show a typical application which places the 7825CCE-3G in stream mode, allows modem Port D to process captions in Field 1, allows Port B to process text articles in field 1, and enables Port C for extended data services.

**6.6.3. Show Port Active Maps**

This command will report the active map for each port. The active map controls what port has control of a data type.

**Command:** ^AO<cr> (capital letter 'O')

**Example result:**

Active Map

**PORT A:** C1

**PORT B:** C2

**PORT C:**

**PORT D:** XDS ONLINE

This example shows Port A is actively controlling the captions in field 1, Port B is controlling the captions in field 2, Port C is not actively controlling any data, and the Port D modem is online and is controlling the extended data services.

**6.6.4. Alter Port Active Maps**

This command will alter the active map for any port by adding or subtracting various data types. The optional override parameter ('O') forces other control ports to relinquish control of the specified data type.

**Command:** ^AO<sp>pn<sp>-dt...dt...dt<sp>ovr<cr>

**Default:** none

**Example:**

```
^AO PB -C1<cr>
```

This command will remove the active indication for Port B from field 1 captions.

`^AO C1<cr>`

This command will indicate that the current port is active in the captions in field 1. Activity for other data types remain as previously set.

`^AO C1 O<cr>`

This command forces the current port to be active in field 1 captions. Activity for other data types remain as previously set. If any other control port is active in CF1 will be reset.

#### **6.6.5. Reset Port**

This command will reset a port. This command immediately clears the input and output data queues and resets the 7825CCE-3G to the Transparent State in Field 1 and Field 2. Article and XDS output queues are not reset by this command. They must be explicitly reset by using the queue articles and queue XDS commands. Since other control ports may be simultaneously sending data, this command only affects the fields and data types that have not been appropriated by other control ports. To reset all communication ports, see the Reset Encoder (^F^F) command in section 6.3.2.

**Command:** `^Ar<sp>pn<u>cr>`

**Example:** `^Ar PB<cr>` Resets Port B

## 7. TROUBLESHOOTING

### 7.1. ANSWERS TO FREQUENTLY ASKED QUESTIONS

#### 7.1.1. Which Serial Port Should I Connect To?

Any serial port can be used for typical captioning functions, since they all use the same Control-A serial protocol. All three serial ports are configured from the factory to work with an off-the-shelf null-modem cable. Ports A, B, and C are all configurable to support both RS-232 and RS-422 communications.



**If the user wishes to connect to an ATSC encoder, Port B must be used. Port B support SMPTE-333M and Grand Alliance protocols, configurable using VistaLINK® menu system of the 7825CCE-3G. Please see section 5.8.**

#### 7.1.2. There is No SDI Video Present on the SDI Output

The 7825CCE-3G includes video bypass relays to ensure that video is passed, even when the unit is powered-down. Make sure that your SDI source is connected to the BNC connector marked INPUT A/B, and the primary SDI video output is connected to the BNC connector marked HD/SDI BYPASS PGM OUT. If you still see no video, try the following:

1. Activate the appropriate A or B bypass relay.
2. Connect your SDI source to the SD-SDI IN connector.
3. Look for video out of the SDI BYPASS PGM OUT connector.

If there is still no SDI video passing through the unit, check for presence of SDI video upstream, and check for cabling problems.

#### 7.1.3. How Do I Check if Captions are Being Processed?

##### 7.1.3.1. Control A Protocol Test Using a Terminal Program

Control-A protocol can be used to determine if captions are processed and available out of Ports A, B, or C. Please ensure the latest firmware is downloaded from [www.evertz.com](http://www.evertz.com) and installed in the 7825CCE-3G.

##### Procedure:

- Connect a null modem cable to Port A, B, or C and to the RS-232 communication port of a PC.
- Begin a Terminal Program (Windows Hyper-terminal) and configure the communication settings to the following:

<b>Baud</b>	9600
<b>Parity</b>	none
<b>Data bits</b>	8
<b>Stop bits</b>	2
<b>Flow Control</b>	None

- Make sure captions are present in the up-stream SD-SDI and/or HD-SDI video or enable the CEA-608 Test Message of the 7825CCE-3G.

- Turn the 7825CCE-3G on.
- Using VistaLINK<sup>®</sup> menu system set the desired port to Control A protocol. See section 5.8
- Set the Port settings to match the settings in Hyper-terminal as shown above.
- Press ENTER on the keyboard and ensure you see an asterisk (\*) prompt every time you push the ENTER key.
- If you do not see the asterisk (\*) prompt, communication has not been established between the 7825CCE-3G and PC. Begin from the beginning of this procedure and ensure all settings are correct.
- At the prompt with the \*astrix in Hyper-Terminal, type in the following command:  
Ctrl + a (the control button on the keyboard plus the letter A button)  
5  
SPACE (space bar)  
f  
1  
*You will not see this displayed at the prompt.*
- Press the ENTER key
- This Control A command is further outlined in section 6.3.4
- All captions in field 1 should now be displayed in HyperTerminal.
- To turn this feature off, type in the following command
- CTRL + g (Control key on the keyboard and the G key)
- The captions will stop scrolling

This test shows the 7825CCE-3G is processing captions and allows the user to verify this through Hyper-Terminal.

If captions are not displayed, check the following:

- Ensure the command was entered properly.
- Are captions present in the upstream video?
- Turn on the CEA-608 Test Message via VistaLINK<sup>®</sup>

#### **7.1.4. There are No Captions Present Out of the ATSC Encoder**

Make sure the correct communication cable is used between the 7825CCE-3G Port B and the ATSC encoder. A null modem cable is used in almost all cases.

Avoid using gender changers, "home made" cables, or distribution boxes between the 7825CCE-3G and ATSC encoder. Ensure a direct path is provided from the 7825CCE-3G to the encoder with a proper working cable.

Ensure Port B is set to the proper protocol and baud rate using VistaLINK<sup>®</sup> menu. See section 5.8 to configure Port B. Verify captions are present on the upstream video.



**Note: Only Port B supports SMPTE-333M and Grand Alliance protocol.**

### **7.1.5. What Baud Rate and Port Settings Should I Use?**

While the unit is capable of running at 57.6k baud on all internal serial ports, it is not necessary to run at the fastest baud rate possible for most captioning operations. NTSC captions are encoded at a maximum of 60 characters per second in each field. A serial port set to 1200 baud can transfer data at up to 120 characters per second including 7-bits of data, start, stop and parity bits. This is adequate for most captioning applications since the communications overhead is generally very low.

Some older PC's do not function correctly at over 19.2k baud, especially when running under Windows. Many PC's also have difficulties at 19.2k baud and above when using only the software (XON/XOFF) flow control method. Try turning on hardware (CTS/RTS) flow control on your computer if the captioning software supports it, and/or reducing your communications baud rate. Make sure that you alter your captioning computer's serial port settings to match those of the caption encoder.

### **7.1.6. Captions are Not Being Encoded At All**

If there is no option in the captioning/teleprompter software for the Evertz encoder, configure your software to communicate with an EEG 270, EEG 370 or EEG 470 model Smart Encoder. The Evertz caption protocol is compatible with these units.

Make sure that the caption encoder unit is set to the correct video type, 525-60 for component SD-SDI.

Check that the caption keyer is turned on.

Check your serial port communications settings. Make sure that these are identical between the caption encoder and the attached captioning computer.

Check that the unit is receiving data from the serial port or modem.

Try enabling the built-in CEA-608 test message. If you still cannot see captions, then it is likely that downstream equipment is corrupting the caption data, or your caption decoder is not functioning correctly.

### **7.1.7. Captions are Not Being Encoded Correctly**

If there is no option in the captioning/teleprompter software for the Evertz encoder, configure your software to communicate with an EEG 270, EEG 370 or EEG 470 model Smart Encoder. The Evertz caption protocol is compatible with these units.

Make sure that the caption encoder unit is set to the correct video type, 525-60 for component NTSC.

Check your serial port communications settings. Make sure that these are identical between the caption encoder and the attached captioning computer.

Check that the unit is receiving data from the serial port or modem.

If certain accented and special characters do not display correctly, this is likely the fault of the caption decoder being used to display the captions. Some decoders do not support the entire character set for captions.

Certain teleprompter software packages have been known to not encode accented characters correctly. Please contact your software provider for possible updates before contacting Evertz technical support.

### **7.1.8. How Can I Block Upstream Captions?**

Depending on the user's specific needs, there are many ways to accomplish this. If all upstream captions are to be blocked, the recommended approach is to issue the serial port commands ^A6 F1 and ^A6 F2 to place both Field 1 and Field 2 into NULL STATE. See section 6.3.13.

If only a particular data channel is to be blocked, such as Text Channel 2, execute the serial command ^A6 T2 to place this particular channel in NULL STATE. To block all upstream XDS material, issuing ^A6 TX will put only the XDS stream into NULL STATE. Presently there is no way to block specific XDS packet types, unless these are being replaced with updated packets of the same type by the caption encoder. If an entire field is to be blocked, use ^A6 F2 to place all of Field 2 in NULL STATE.

### **7.1.9. How Can I Pass Upstream Captions?**

If upstream captions are being blocked, the user's captioning software might have failed to relinquish control of the encoder so upstream captions may pass.

If captioning software is leaving the unit in DIRECT STATE or REAL TIME STATE or NULL STATE when it is sitting idle, this issue must be resolved in the caption software itself.

### **7.1.10. My Modem Connection Hangs-Up Unexpectedly**

The following can cause unexplained hang-ups on a modem connection:

**RAIN** - If there has been any significant rainfall during this time, moisture can get into the lines and cause power hums and other sorts of phenomenon. This can cause the DC level of the phone line to vary, which modems can interpret as loss of carrier.

**DISTANCE** - If the captioner is a long distance from the CO (Central Office) where they are near the limit of transmission, dropouts can occur if there is not a line booster in place. If there is a line booster, this can also be a problem if there are grounding issues, etc.

**CAPTIONERS MODEM** - If the initialization string is setup incorrectly, this can cause the modem to not function correctly. The user may want to check the modem manufacturer for the recommended set-up for their particular modem so it is capable of operating in the 1200 to 2400 baud range. Some people that use US Robotics 57.6k modems have reported difficulties connecting at lower baud rates due to these setup strings.

**OTHER SOFTWARE** - If there is any other software on the system that uses the modem, it may have changed the initialization string or be interfering with the modem. On computers that use a COM-port mouse, the mouse may also interfere with the modem operation if it is configured incorrectly.

**READ THE MANUAL** - Be sure the captioners know their system inside and out. They should, at minimum, be able to supply what their system configuration is.

**CALL WAITING** - If this service is installed on the captioner's phone line, it **MUST** be disabled before using the modem. If an outside caller tries to call the phone line that the modem is connected to, the tone that is generated will disrupt modem communications, resulting in loss of carrier.

**ONLY CONNECT TO POTS** (Plain Old Telephone System) - For a reliable telephone connection to the caption encoder a direct telephone line must be used. This line must not pass through a PBX or similar key device.



Today, many telephone companies digitize the signal within their networks, unbeknownst to the customer. You may be able to establish a reliable connection to the caption encoder at 1200 or 2400 baud, but no higher. (This speed is acceptable for most captioning applications.) In other cases, you may need to ask the telco for a phone line with higher bandwidth, possibly at extra charge.

**ENSURE THE LATEST FIRMWARE IS INSTALLED** - From time-to-time, Evertz may release updated firmware for the 7825CCE-3G to add new features or improve performance. It is recommended to always check for firmware updates when you encounter a problem. The firmware release notes will provide some guidance as to whether a firmware upgrade will address your specific problem.

## **7.2. BEFORE YOU CALL EVERTZ TECHNICAL SUPPORT**

Check for any product upgrades that may address your problem at the Evertz web site ([www.evertz.com](http://www.evertz.com)) and consult your software vendor.

After reviewing the website and calling Evertz customer service, you will be asked for specific technical information, which should be prepared in advance for speedy assistance:

- Serial number of unit.
- Firmware version of the caption encoder. This is displayed in VistaLINK® via Help...version information.
- Which serial ports and modem ports (A through E) are being used on the encoder?
- What captioning or teleprompter software is being used to control the encoder? (manufacturer, product name, revision number)
- Is this a new installation, or was the unit functioning in your system previously?
- Did the problem occur after installing some new hardware or software?

*This page left intentionally blank*

## 8. GLOSSARY

### 8.1. GLOSSARY OF STANDARDS

**CEA (Consumer Electronics Association):** CEA is a professional organization that recommends standards and practices for the U.S. consumer electronics industry.

**CEA-608:** This CEA standard serves as a technical guide for those providing encoding equipment and/or decoding equipment to produce material with encoded data embedded in Line 11 of the vertical blanking interval of the NTSC video signal. It is also a usage guide for those who will produce material using such equipment

**CEA-708:** Defines the coding of DTV closed captions (DTVCC) as they are delivered in an ATSC signal, and also defines the Caption Distribution Packet (CDP). This structure contains fields that can hold: CEA-608-B data for use if the video is converted to standard definition analog; DTV captions for use in an ATSC program; Caption Descriptors; and Time Code. The CDP is the basic unit of data that is transported through the professional portion of a DTV plant. As such, it is central to the methods discussed in this document.

**SMPTE (Society of Motion Picture and Television Engineers):** A professional organization that recommends standards for the film and television industries.

**SMPTE 12M-1:** The SMPTE standard for the Time and Address Control signal in widespread use in the professional video and audio industries. SMPTE 12M-1 defines the specifications for both Linear Time Code (LTC) and Vertical Interval Time Code (VITC).

**SMPTE 12M-2:** The SMPTE Recommended Practice for transmitting Time code in the ancillary data space of serial digital television signals

**SMPTE 125M:** The SMPTE standard for bit parallel digital interface for component video signals. SMPTE 125M defines the parameters required to generate and distribute component video signals on a parallel interface.

**SMPTE 244M:** The SMPTE standard for bit parallel digital interface for composite video signals. SMPTE 244M defines the parameters required to generate and distribute composite video signals on a parallel interface.

**SMPTE 259M:** The SMPTE standard for 525 line serial digital component and composite interfaces.

**SMPTE 269M:** This SMPTE standard defines an opto-isolated fault tally output signal for connecting to user-defined equipment such as warning indicators.

**SMPTE 291M:** Defines the method of multiplexing ancillary data such as audio and captions to 292M and 259M-C signals.

**SMPTE 292M:** Defines the serial interface that is used for carriage of HDTV video signals. It and its standard definition equivalent 259M-C provide a standard transport mechanism, not only for the video signal, but also for digitized audio and data such as captions.

**SMPTE 309M:** The SMPTE standard for encoding date information into the user bits of linear time code.

- SMPTE 333M:** Standard for serially interfacing captioning equipment with ATSC video encoders
- SMPTE 334M:** Assigns addresses to be used to encode captioning into the vertical ancillary (VANC) space defined by 291M. Also specifies that the payload of a VANC packet used for captioning is CDP. Supeceded by SMPTE-334-1 and SMPTE-334-2.
- SMPTE 334-1:** Vertical Ancillary Data Mapping of Caption Data and Other Related Data.
- SMPTE 334-2:** Caption Distribution Packet (CDP) Definition.
- SMPTE 425M:** Specifies the mapping of different video signals to the 3G physical interface, as well as the supported video formats.
- SMPTE RP2007:** CDP and "Grand Alliance" serial communication interfaces.

## **8.2. GLOSSARY OF TERMS**

- AES:** (Audio Engineering Society) A professional organization that recommends standards for the audio industries.
- AES/EBU:** Informal name for a digital audio standard established jointly by the Audio Engineering Society and the European Broadcasting Union organizations.
- ANALOG:** An adjective describing any signal that varies continuously as opposed to a digital signal that contains discrete levels representing digits 0 and 1.
- A-TO D CONVERTER (ANALOG-TO-DIGITAL):** A circuit that uses digital sampling to convert an analog signal into a digital representation of that signal.
- ATSC A/65:** Defines information that describes the contents of an ATSC broadcast. Some of this information may pertain to the closed captioning.
- BIT:** A binary representation of 0 or 1. One of the quantized levels of a pixel.
- BIT PARALLEL:** Byte-wise transmission of digital video down, a multi-conductor cable where each pair of wires carries a single bit. This standard is covered under SMPTE 125M, EBU 3267-E and CCIR 656.
- BIT SERIAL:** Bit-wise transmission of digital video down, a single conductor such as coaxial cable. May also be sent through fiber optics. This standard is covered under SMPTE 259M-C and CCIR 656.
- BIT STREAM:** A continuous series of bits transmitted on a line.
- BNC:** Abbreviation of "baby N connector". A cable connector used extensively in television systems.
- BYTE:** A complete set of quantized levels containing all the bits. Bytes consisting of 8 to 10 bits per sample are typical in digital video systems.

**CABLE EQUALIZATION:** The process of altering the frequency response of a video amplifier to compensate for high frequency losses in coaxial cable.

**CDP:** Caption Distribution Packet, was defined in SMPTE-334M-2006 (and formerly in CEA-708-B). CDPs may contain CEA-708 and/or CEA-608 caption data.

**CCIR (International Radio Consultative Committee):** An international standards committee. (This organization is now known as ITU.)

**CCIR-601:** See ITU-R601.

**CCIR-656:** See ITU-R656.

**CLIFF EFFECT:** (also referred to as the 'digital cliff') This is a phenomenon found in digital video systems that describes the sudden deterioration of picture quality when due to excessive bit errors, often caused by excessive cable lengths. The digital signal will be perfect even though one of its signal parameters is approaching or passing the specified limits. At a given moment however, the parameter will reach a point where the data can no longer be interpreted correctly, and the picture will be totally unrecognizable.

**COMPONENT ANALOG:** The non-encoded output of a camera, video tape recorder, etc., consisting of the three primary colour signals: red, green, and blue (RGB) that together convey all necessary picture information. In some component video formats these three components have been translated into a luminance signal and two colour difference signals, for example Y, B-Y, R-Y.

**COMPONENT DIGITAL:** A digital representation of a component analog signal set, most often Y, B-Y, R-Y. The encoding parameters are specified by ITU-R601. ITU-R656 and SMPTE 125M specify the parallel interface.

**COMPOSITE ANALOG:** An encoded video signal such as NTSC or PAL video that includes horizontal and vertical synchronizing information.

**COMPOSITE DIGITAL:** A digitally encoded video signal, such as NTSC or PAL video that includes horizontal and vertical synchronizing information.

**D1:** A component digital video recording format that uses data conforming to the ITU-R601 standard. Records on 19 mm magnetic tape. (Often used incorrectly to refer to component digital video.)

**D2:** A composite digital video recording format that uses data conforming to SMPTE 244M. Records on 19 mm magnetic tape. (Often used incorrectly to refer to composite digital video.)

**D3:** A composite digital video recording format that uses data conforming to SMPTE 244M. Records on 1/2" magnetic tape.

**DSO:** (Daylight Saving time Observed)

**DST (DAYLIGHT SAVING TIME):** The civil time observed when daylight saving time is adopted in a country or region. It is usually standard time + 1 hour. (see also *Standard Time*)

**DTVCC:** Digital Television Closed Captioning, defined in CEA-708.

**EBU (European Broadcasting Union):** An organization of European broadcasters that among other activities provides technical recommendations for the 625/50 line television systems.

**EBU TECH 3267-E:** The EBU recommendation for the parallel interface of 625 line digital video signal. This is a revision of the earlier EBU Tech 3246-E standard that was in turn derived from ITU-R601.

**EDH:** Error Detection and Handling (EDH) is defined in SMPTE RP-165 as a method of determining when bit errors have occurred along the digital video path. Check words and flags are combined into a special error detection data packet that is included as ancillary data in the serial digital signal.

**EMBEDDED AUDIO:** Digital audio is multiplexed onto a serial digital video data stream.

**EXTENDED DATA SERVICES (XDS):** XDS is a third data service in field 2 that is intended to supply program related and other information to the viewer. This information may include such items as program title, length of show, type of show and program content codes such as V-Chip program ratings.

**ITU:** The United Nations regulatory body governing all forms of communications. ITU-R (previously CCIR) regulates the radio frequency spectrum, while ITU-T (previously CCITT) deals with the telecommunications standards.

**ITU-R601:** (This document previously known as CCIR-601). An international standard for component digital television from which was derived SMPTE 125M and EBU 3246-E standards. ITU-R601 defines the sampling systems, matrix values and filter characteristics for both Y, B-Y, R-Y and RGB component digital television signals.

**ITU-R656** (This document previously known as CCIR-656). The physical parallel and serial interconnect scheme for ITU-R601. ITU-R656 defines the parallel connector pinouts as well as the blanking, sync and multiplexing schemes used in both parallel and serial interfaces. It reflects definitions found in EBU Tech 3267 (for 625 line systems) and SMPTE 125M (parallel 525 line systems) and SMPTE 259M-C (serial 525 line systems).

**JULIAN DATE:** The Julian day number is a count of days elapsed since Greenwich mean noon on January 1, 4713B.C. January 1st, 1993 was JD 2448989; January 1st, 2000 was JD 2451545.

**MODIFIED JULIAN DATE (MJD):** The Modified Julian Date is a continuous count of the number of days elapsed since 17 November 1858. It is often more useful than conventional calendar dates for record keeping over long periods of time, since the MJD's of two events can easily be subtracted to determine the time difference in days. Usually, the MJD is specified as a number with 5 significant digits. As an example, the MJD for 1 January 1995 is 49718, meaning that this many days have elapsed between 17 November 1858 and 1 January 1995. The Modified Julian date is calculated by subtracting 2400000.5 days from the Julian Date. Thus the Modified Julian Day 1 begins at Greenwich midnight.

**LED:** Light Emitting Diode.

**LINEAR TIME CODE (LTC):** A digital code used for timing and control purposes on videotape and associated audiotape machines. It is recorded on a longitudinal track with audio characteristics and is referred to as LTC (Sometimes this code is also referred to as longitudinal code or SMPTE). Each 80 bit code word is associated with one television frame, and consists of 26 time bits, 6 flag bits, 32 user bits and 16 sync bits. Date information may be optionally encoded into the user bits. This code is often used for distribution time of day information to station clock displays and automation systems. The SMPTE 12M standard defines LTC.

**PAC:** Preamble Address Code. These codes are embedded into the line 21 caption data. They define the caption text position on the screen, and set special features such as colour, italics and underline.

**PIXEL:** The smallest distinguishable and resolvable area in a video image. A single point on the screen. In digital video, a single sample of the picture. Derived from the words *picture element*.

**PSIP:** Program and System Information Protocol, defined in ATSC A/65.

**RESOLUTION:** The number of bits (eight, ten, etc.) determines the resolution of the signal. Eight bits is the minimum resolution for broadcast television signals.

**SERIAL DIGITAL (SDI):** Digital information that is transmitted in serial form. Often used informally to refer to serial digital television signals.

**STANDARD TIME:** The civil time adopted for a country or region. (See also *Daylight Saving Time*)

**TIME ZONE OFFSET:** The difference in time between the local time and UTC

**TRS:** Timing reference signals used in composite digital systems. (It is four words long).

**TRS-ID:** Abbreviation for "Timing Reference Signal Identification". A reference signal used to maintain timing in composite digital systems. (It is four words long.)

#### **UNIVERSAL COORDINATED TIME**

**UNIVERSAL TIME, COORDINATED (UTC):** An international time standard that defines a time that doesn't depend on where we are on Earth. Universal Time (UTC), Greenwich Mean Time (GMT), and Zulu Time (Z), are based at the prime meridian (0° longitude) of Earth and are used to avoid confusion of time zones.

**VANC:** Vertical Ancillary data. Data carried in serial digital video signal (SMPTE 259M-C or 292M), in accordance with SMPTE 291M, in the active portion of scan lines that are outside the active picture area.

**VBI:** Vertical Blanking Interval. The scan lines that are outside the active picture area of a standard definition video signal (analog or serial digital). These can be used for carriage of data, including closed captioning, in analog video broadcasting.

- V-Chip:** Abbreviation for “Viewer Chip” (commonly misread as “Violence Chip”). V-Chip-enabled television sets extract Program Rating packets from the XDS data stream in Field 2 captions to determine the rating of a show. Also see Extended Data Services.
- WebTV:** The encoding of URL (Uniform Resource Locators) normally used on the Internet, into line 21 caption style data. This URL string is made up with the familiar http:// followed by a target location on the Internet. The URL must be formatted to match the Electronic Industries Association specification CEA-746-A.
- XDS:** See Extended Data Services.
- 4:2:2** A commonly used term for a component digital video format. The details of the format are specified in the ITU-R601 standard. The numerals 4:2:2 denote the ratio of the sampling frequencies of the luminance channel to the two colour difference channels. For every four luminance samples, there are two samples of each colour difference channel.
- 4Fsc** Four times sub-carrier sampling rate used in composite digital systems. In NTSC this is 14.3 MHz. In PAL this is 17.7 MHz.